

These assembly and operating instructions apply to:

Control Unit	NVM C1W
Control Unit	NVM C4W
Control Unit	NVM C4
Sensor	NVM S10



## Contents

<b>1</b>	<b>GENERAL NOTES</b>	<b>3</b>
<b>2</b>	<b>SAFETY</b>	<b>5</b>
<b>3</b>	<b>TECHNICAL DATA</b>	<b>6</b>
<b>4</b>	<b>DESIGN AND FUNCTIONING</b>	<b>8</b>
<b>5</b>	<b>TRANSPORT AND STORAGE</b>	<b>9</b>
<b>6</b>	<b>ASSEMBLY</b>	<b>9</b>
6.1	Connection of control unit NVM C1W .....	10
6.2	LED status display control unit NVM C1W.....	11
6.3	Connection of control unit NVM C4W .....	12
6.4	LED status display control unit NVM C4W.....	12
6.5	Adjusting the number of sensors at the control unit NVM C4W .....	13
6.6	Connection of control unit NVM C4.....	14
6.7	Connection of sensor.....	15
<b>7</b>	<b>SPARE PARTS</b>	<b>16</b>
<b>8</b>	<b>ANNEX</b>	<b>16</b>
8.1	Accessories.....	16
8.2	Disposal .....	16
8.3	Enclosures .....	16

## Scope of supply



### IMPORTANT

Check the packing for possible shipping damage.  
If the packing is damaged, check the contents for completeness and possible damage. In case of damage inform the transport agent.  
Compare the scope of supply with the delivery note.

## 1 General Notes

Netter vibration monitoring systems series **VibroMonitor** comply with the Electromagnetic Compatibility Directive 2004/108/EC and the Low Voltage Directive 2006/95/EC. In particular, the standards DIN EN 61010 - 1 and DIN EN 61326 - 1 have been observed.

Vibration monitoring systems are used for permanent monitoring applications as they are required for impactors, vibrators and vibrating systems.

### Special features:

- Permanent monitoring of vibration systems
- Radio suppression
- Operation mode: electronic
- Control unit mounted on M36-DIN rail







### IMPORTANT

#### Important note:

Before use of the Netter vibration monitoring systems series **VibroMonitor** read these assembly and operating instructions carefully and keep them stored close to the vibrators afterwards.

This documentation is copyrighted. All rights, e.g. for translation into other languages, reprinting and copying of these operating instructions or parts hereof remain strictly reserved.

In these operating instructions the following information and danger symbols are used.

	<b>DANGER</b>	points out a possible danger which might result in death or serious injury if the respective instruction is not complied with.
	<b>WARNUNG</b>	points out a possible danger which might lead to personal injury or equipment damage if the respective instruction is not complied with.
	<b>DISCONNECT UNIT FROM MAINS SUPPLY</b>	points out a possible danger which might lead to personal injury if the respective instruction is not complied with.
	<b>IMPORTANT</b>	Note containing especially useful information and tips.
	<b>ENVIRONMENTALLY FRIENDLY WASTE DISPOSAL</b>	points out the obligation to dispose of waste in an environmentally friendly way.

## 2 Safety

### Intended use:

The vibration monitoring systems are designed for installation in machines. These devices use vibrations for sieving, loosening, conveying, compacting and separating bulk material.

Any other use is considered improper use.

### Qualification of the personnel:

Assembly, commissioning, maintenance and repair of the vibration monitoring systems must be performed only by authorized qualified personnel.

Any handling of the vibration monitoring systems lies within the responsibility of the user.

There are no independent safety devices.

Accessories which ensure the correct operation and safety must provide a protection type required for the specific use.



**DANGER**

Live parts can cause severe or fatal injuries.



**CAUTION**

The vibration monitoring systems are built in accordance with the latest EC directives.

The assembly, installation, commissioning and maintenance must be performed only by authorized personnel.

The installation and operation of the vibration monitoring system is to be carried out in accordance with the requirements of the local electrical engineering associations (e.g. VDE) and the known accident prevention rules.



**CAUTION**

**Netter GmbH will not be liable for any damage or injury if the product has been technically modified or if the instructions of this operating manual have not been observed.**

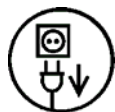

**DISCONNECT  
UNTI FROM  
POWER  
SUPPLY**

When working on the vibrators, these must be isolated from the mains supply. To do so, please proceed as follows:

1. Switch off the vibrator
2. Secure it against accidental activation
3. Make sure it is deenergized

### 3 Technical Data



**IMPORTANT**

**Operating voltage :** 24V DC (+20%/-10%), <5% residual ripple  
**Ambient temperature:** Control unit C1W 0°C to 40°C  
 Control unit C4W 0°C to 40°C  
 Control unit C4 -20°C to 40°C  
 Sensor S10 -20°C to 40°C  
 The ambient temperature range must not be exceeded or fallen short of.

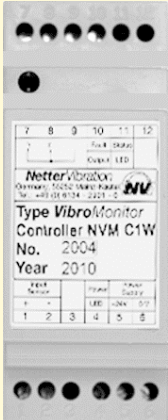
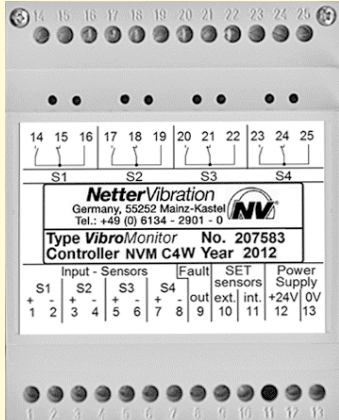
<i>VibroMonitor</i>	Control unit Type NVM C1W	Control unit Type NVM C4W
		
<b>Sensor inputs</b>	1 x unpolarized	4 x unpolarized
<b>Relay outputs</b>	1 x switching output	4 x switching output
<b>Digital outputs</b>	<p>potential-free change-over, max. 30 V DC, max. 2 A</p> <p>If the acceleration value is <i>greater</i> than the set treshold, the normally open contact <i>closes</i> (the NC contact opens).          If the acceleration value is <i>lower</i> than the set treshold, the normally open contact <i>opens</i> (the NC contact closes).</p>	
<b>Status LEDs</b>	1 x operating voltage 1 x sensor status	8 x sensor status
<b>Faults</b>	1 x fault output (cable break- or short-circuit)	
<b>Setting</b>		2 x SET inputs <i>Externally</i> via a switch to 0 V <i>Internally</i> via a button on the board
<b>Installation</b>	M36-DIN standard rail (EN50022)	
<b>Dimensions HxWxD</b>	70 x 35 x 90 mm	70 x 70 x 90 mm

<b>VibroMonitor</b>	<b>Control unit Typ NVM C4</b>
	
<b>Sensor inputs</b>	4 x unpolarized
<b>Digital outputs</b>	4 x NPN, max. 8 mA <ul style="list-style-type: none"> <li>- If the acceleration value is greater than 9.81 m/s<sup>2</sup> (&gt; 1.0 a<sub>g</sub>), an external load (to +24 V DC) is pulled to 0 V.</li> <li>- If the acceleration value is less than 9.81 m/s<sup>2</sup> (&lt; 1.0 a<sub>g</sub>), an external load remains on its potential (+24 V DC).</li> </ul>
<b>Status LEDs</b>	1 x operating voltage control, 4 x sensor status
<b>Fault</b>	4 x visual indicator display
<b>Mounting</b>	M36-DIN standard rail (EN50022)
<b>Dimensions HxWxD</b>	70 x 70 x 90 mm

<b>VibroMonitor</b>	<b>Sensor NVM S10</b>
	
<b>Type</b>	capacitive, monocrystalline (MEMS), integrated amplifier
<b>Connection</b>	4-pin socket for round connectors M12 x 1 (preferably with cap nut and interlock)
<b>Material</b>	Cylindrical sensor made of stainless steel
<b>Shock acceleration</b>	max. 981 m/s <sup>2</sup>
<b>Switching threshold adjustable</b>	0.....98,1 m/s <sup>2</sup> Default setting: 3,5 g <sub>e</sub> (RMS) 5,0 g <sub>e</sub> (peak)
<b>Cable length</b>	between sensor and control unit: max. 250 m
<b>Dimensions</b>	Ø 12 x 40, thread (plug) M12 x 1

The connection diagram is shown on the type label.

## 4 Design and Functioning

The *VibroMonitor* vibration monitoring system is used for the constant monitoring of vibration units. It consists of up to four acceleration sensors and a control unit, which provides both the power supply for the sensors and signal analysis.

In combination with a controller the signals can be directly used for additional operations.

The system distinguishes two conditions for each connected sensor.

1. Vibration active
2. No vibration

If the acceleration at a sensor is higher than the set switching threshold (default value is  $9.81 \text{ m/s}^2$ ), the system reports "Vibration active". Accelerations below the switching threshold lead to the signal "no vibration".

To ensure that also short impacts, e.g. of impactors, are reliably detected, the "Vibration active" signal has a delay time of 450 ms.

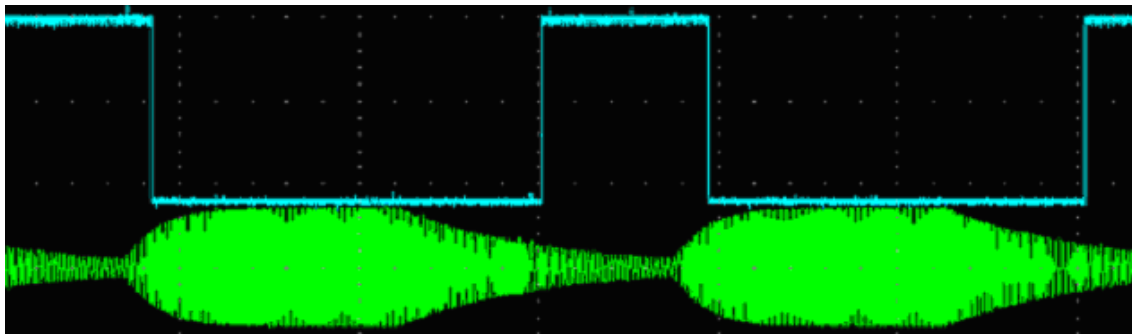

Monitoring of a vibrator with a frequency of 50 Hz.  
The digital output of the VibroMonitor (blue) shows the accelerations (green) exceeding the switching threshold of  $9.81 \text{ m/s}^2$ .

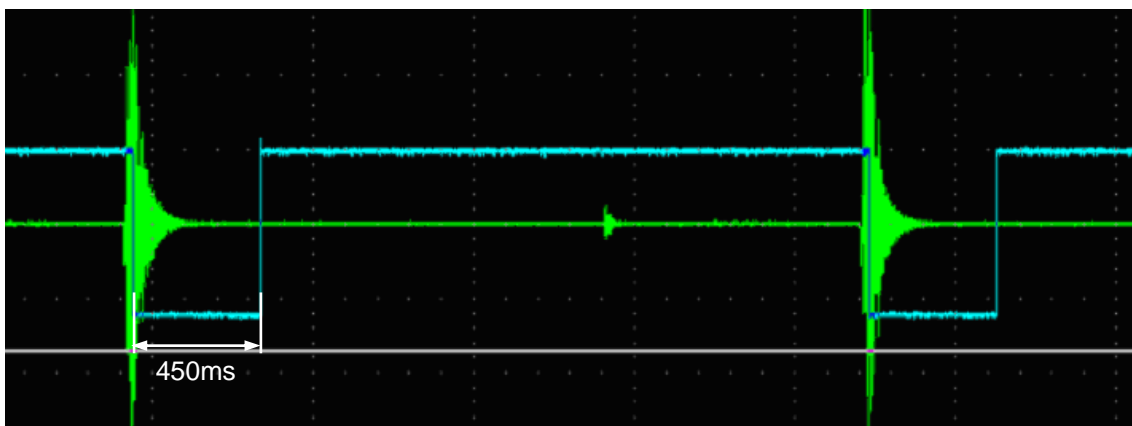

Detection of impacts in the millisecond range.  
The digital output of the VibroMonitor (blue) holds its status for at least 450 ms and therefore reliably records even short impacts (green acceleration signal).

## 5 Transport and Storage



**IMPORTANT**

Check the packaging for possible shipping damage.  
If damage to the packaging is found, check the content for completeness and possible damage. In case of damage, inform the forwarding agent

The units are packed ready for installation. When transporting the vibration monitoring system, make sure that the unit is not subject to extreme shocks or vibrations.

The unit should be stored in a clean, dry environment.

If the vibration monitoring system needs to be in storage for a longer period of time, the temperature in the store must not lie below 0°C or above 40°C and the relative air humidity must not exceed 60%.

## 6 Assembly

The control unit is to be mounted on a M36-DIN-standard rail.

For protection against dust and water jets (protection type IP 65) it has to be installed in a switch box or switch cabinet.

The sensors are mounted directly on the vibrating part with use of a plastic clamp holder or a rubberized clamp.

Bear in mind that for linear vibrations the longitudinal axis of the sensor must be parallel to the direction of vibration.



**CAUTION**

During installation, the safety regulations in chapter 2 and the accident prevention rules must be strictly observed!

Installation of the system must be performed in compliance with the local, applicable regulations (e.g. VDE regulations).



**DANGER**

Use a suitable supply cable for the installation. Connect cables and protective conductors correctly.

The electric cables have to be installed carefully and it has to be ensured that the cables are not worn through by vibrating parts.

The proper condition of the electric cables and plugs has to be checked at regular intervals (as a rule every six months). Discovered faults have to be immediately eliminated.

Protect the cable against high temperatures, lubricants and sharp edges.

### 6.1 Connection of control unit NVM C1W

The Control unit needs an operating voltage of 24 V DC.

Connection: C1W

**Clamp 5: +24 V DC, clamp 6: 0 V.**

The acceleration sensor is connected to the input clamps **1 -** and **2 +**. Attention: Make sure polarity is correct.

The sensor status can be captured using a relay output on **clamps 7 to 9**. The external voltage source is connected to **clamp 9**. If the acceleration at the sensor exceeds the switching threshold, the relay contact connects **clamps 7 and 9** or disconnects **clamps 8 and 9**. Once the

acceleration drops below the switching threshold, at the earliest, however, after **450 ms**, the relay contact returns to its initial position, disconnecting **clamps 7 and 9** and reconnecting **clamps 8 and 9**. The maximum switching voltage must not exceed **30 V DC**, the maximum permitted switching current is **2.0 A**.

It is possible to use the **NPN output** on **clamp 10** to query externally whether there is a fault. The fault outputs on several NVM C1 control units can be monitored simultaneously by parallel connection.

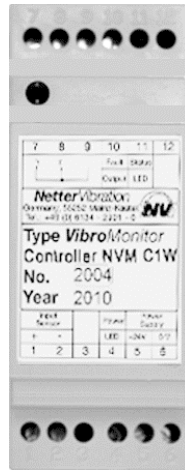

Clamp	Configuration
1	Sensor input
2	Sensor input
3	-
4	Power LED
5	+ 24 V
6	0 V
7	Relay output NO contact
8	Relay output NC contact
9	Relay output lead
10	NPN fault output
11	Status LED
12	-

Clamp assignment NVM C1W

## 6.2 LED status display control unit NVM C1W

The power LED (clamp 4) indicates whether the operating voltage is applied and the fuse of the voltage input is intact.

If the operating voltage is applied to the control unit, the status LED (**clamp 11**) lights up for **about 3 seconds** provided that the sensor is properly connected and working. Then, the system is ready for operation. During operation, the status LED will show a faint light, if the sensor is connected and ready to operate and the measured acceleration is below the threshold of 9.81 m/s<sup>2</sup>. If the

acceleration at the sensor exceeds the switching threshold, the status LED will change to bright light. If no sensor is connected, the sensor is not correctly connected, or there is a cable break, the status LED lights up orange. If there is a short circuit in the sensor cable, the status LED lights up red. In case of short circuits lasting more than 500 ms, the unit must be disconnected from the supply voltage to reset it.

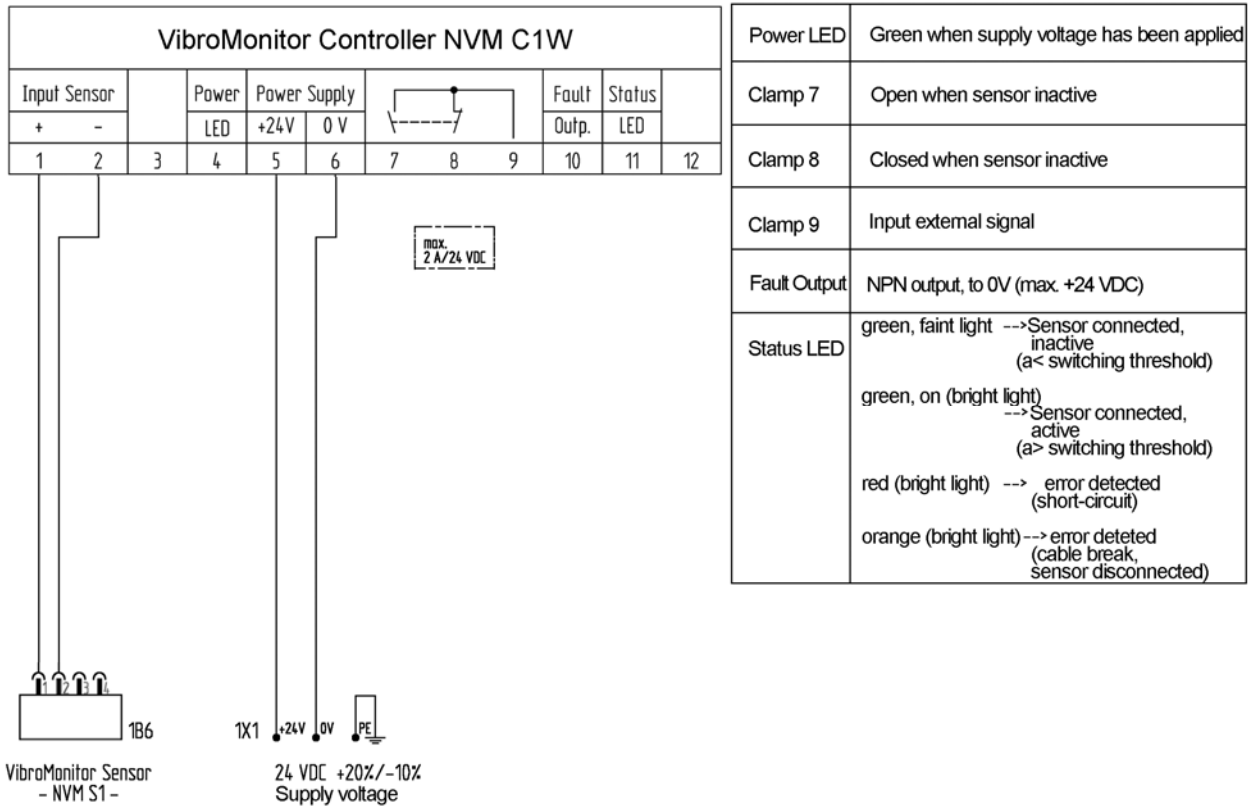

Displays of the status LED

### 6.3 Connection of control unit NVM C4W

The control unit requires an operating voltage of **24 V DC**.

Connection:

**Clamp 12: +24 V DC, clamp 13: 0 V.**

Up to four sensors can be connected to the input clamps **1 to 8** (S1 to S4),

whereby attention needs to be paid to the polarity.

Via the relay outputs at the **clamps 14 to 25** (S1 bis S4) the status of the sensors can be captured e.g. for the digital inputs of a PLC.

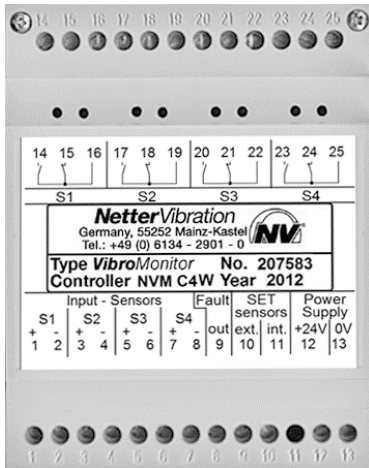

Clamp configuration NVM C4W

Clamp	Configuration	Clamp	Configuration
1	Sensor input 1	14	NO
2		15	NC
3		16	COM
4		17	NO
5	Sensor input 2	18	NC
6		19	COM
7		20	NO
8		21	NC
9	Sensor input 3	22	COM
10	Sensor input 4	23	NO
11		24	NC
12		25	COM
13		0 V	

Clamp configuration NVM C4W

### 6.4 LED status display control unit NVM C4W

If operating voltage is applied to the control unit, the status LEDs assigned to the sensors light up if the respective sensors are properly connected and working. Then, the system is ready for operation. During operation, the respective status LED shows a weak light, if the associated sensor is connected and ready to operate, and the

measured acceleration is below the threshold of **9.81 m/s<sup>2</sup>**. If the acceleration at one of the sensors exceeds the switching threshold, the associated status LED shows a bright light and the respective output switches. The fault LED lights up either in case of cable break, not connected sensor or if there is a short-circuit in the sensor input.

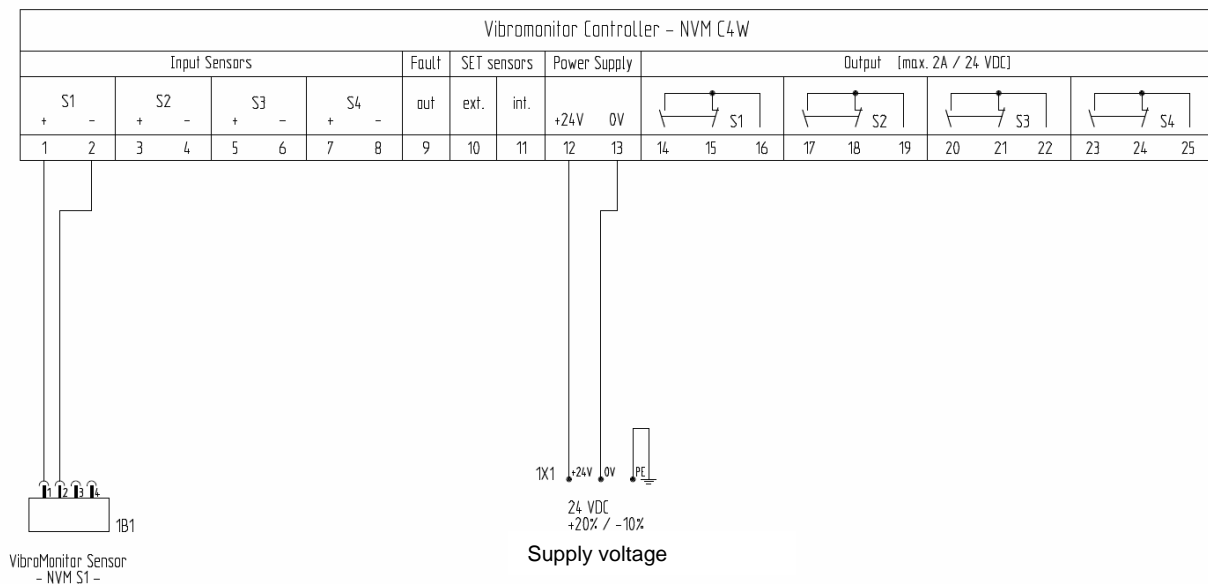

## **6.5 Adjusting the number of sensors at the control unit NVM C4W**

If not all sensor connections of the control unit are required, not used inputs and outputs can be switched off.

After applying the operating voltage the connected sensors will be detected by the status LEDs. If e.g. only 2 sensors are connected to S1 and S2, the green status LEDs at S1 and S2 and the red error LEDs at S3 and S4 light up and the output fault shows an error. This can indicate that either no sensors are connected to S3 and S4 or that there is a short-circuit or cable break on the respective sensors. If the sensor inputs S3 and S4 (or any other combination)

are not required, the control unit can be adjusted to the connected sensors. This can be done via PIN 10 using an external button with a reference potential of 0V or via PIN 11 using a button in the housing. To teach the control unit, the external or internal switches are activated at least 3 seconds. After this the control unit is adjusted to the connected sensors which can be seen by the extinguished error LEDs. This condition is maintained even in case of voltage failure until the pushbutton is activated for at least 0,5 s.

### 6.6 Connection of control unit NVM C4

The control unit requires an operating voltage of **24 V DC**.

Connection:

**Clamp 12: +24 V DC, clamp 13: 0 V.**

Up to four sensors can be connected to the input clamps **1 to 8** (S1 to S4), whereby attention needs to be paid to the polarity.

Via the relay outputs at the **clamps 14 to 25** (S1 bis S4) the status of the sensors can be captured e.g. for the digital inputs of PLC.

By means of active PNP inputs, e.g. digital inputs of a PLC, the status of the sensors at the output clamps 16 to 19 (S1 bis S4) can be captured.

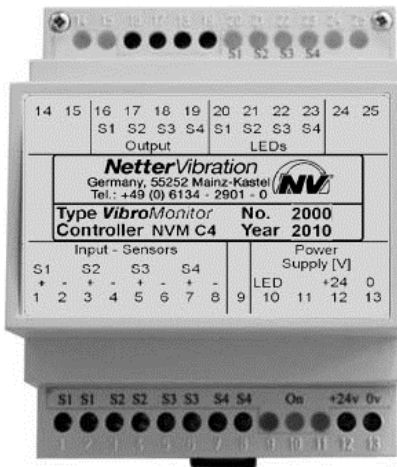

Clamp	Configuration	Clamp	Configuration
1	Sensor input 1	14	-
2		15	-
3	Sensor input 2	16	NPN output 1
4		17	NPN output 2
5	Sensor input 3	18	NPN output 3
6		19	NPN output 4
7	Sensor input 4	20	Status LED 1
8		21	Status LED 2
9	-	22	Status LED 3
10	Power LED	23	Status LED 4
11	-	24	-
12	+ 24 V	25	-
13	0 V		

Clamp configuration NVM C4

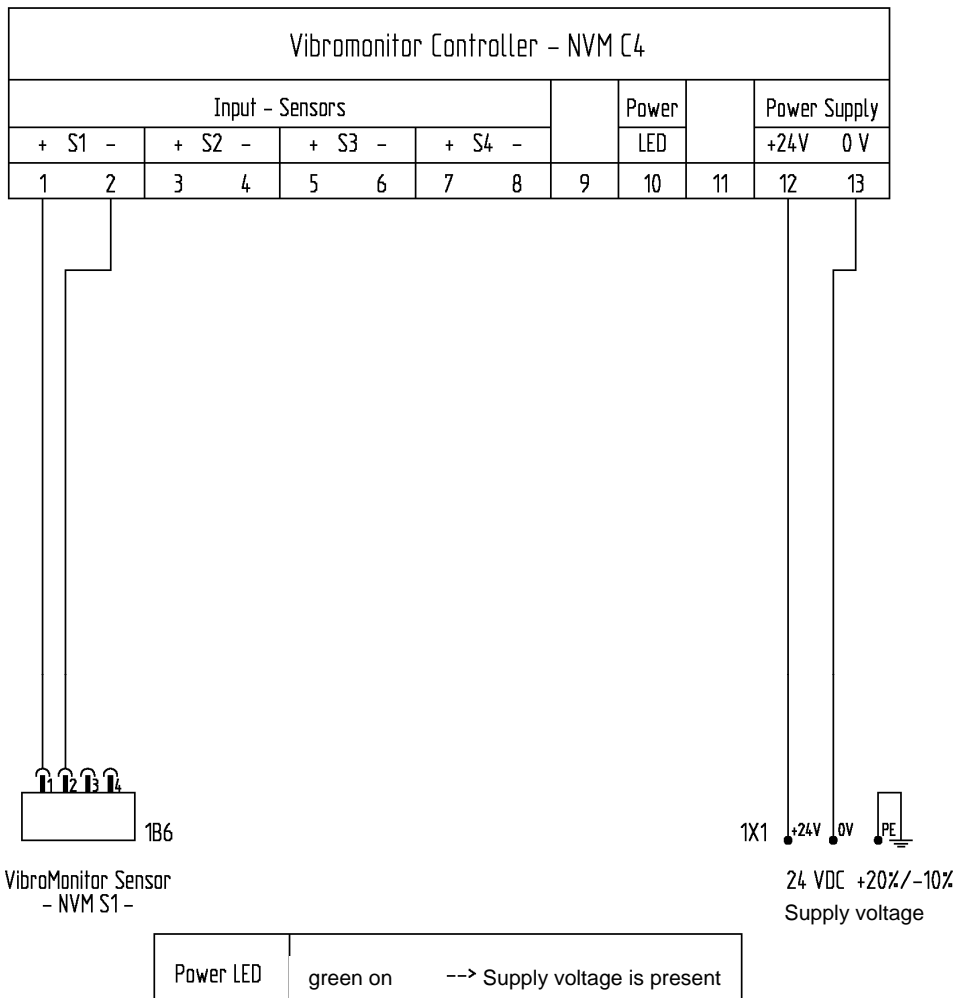

## Connection Diagram

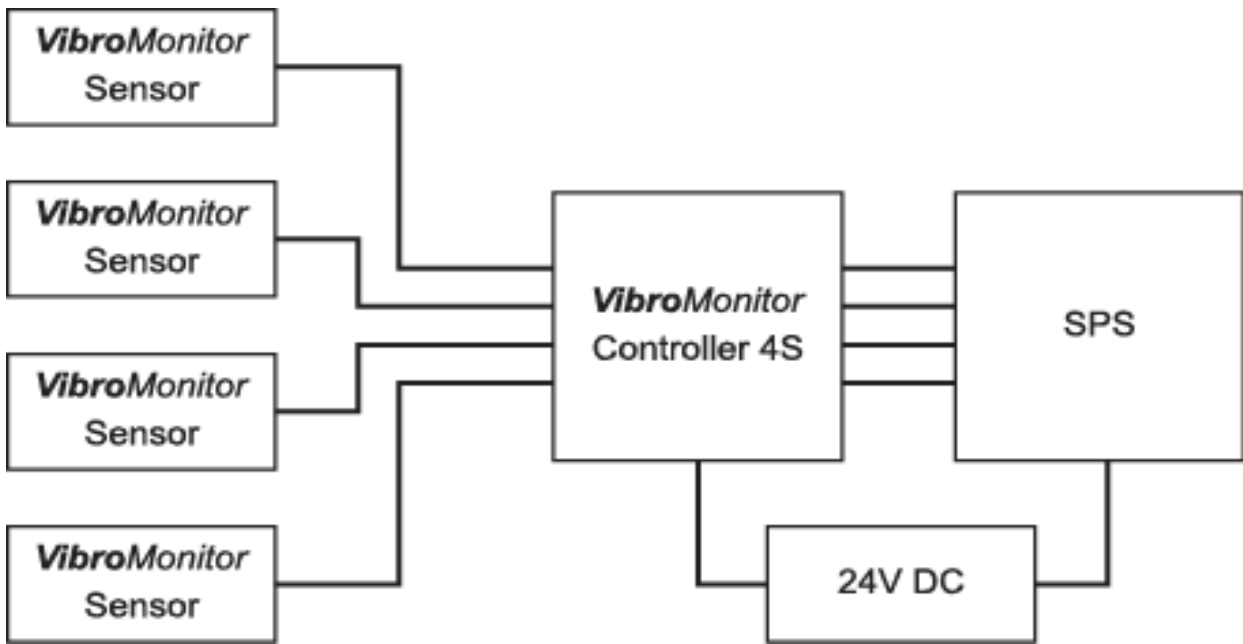

### 6.7 Connection of sensor

The sensor has a socket for 4-pin plug connector with nut M12 × 1 (preferably with integrated screw locking).

The length of the sensor cable must not exceed 250 m.

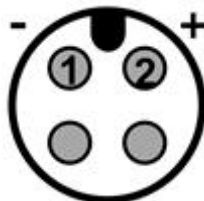

Sensor



Connector

The pins 1 and 2 need to be connected to one of the two-pole sensor inputs on the control unit.

**Pin 1 = -**  
**Pin 2 = +**



Assignment of the sensor pin and sensor connector

## 7 Spare Parts

When ordering spare parts, you should always provide the following details:

1. Type of unit
2. Description and part number
3. Required quantity

## 8 Annex

### 8.1 Accessories

<b>Connecting components</b>	
Sensor connecting cable 5 m	With angled socket M12 × 1 and free cable end, Material: PUR <b>Part No.: 65000254</b>
Sensor connecting cable 10 m	With angled socket M12 × 1 and free cable end, Material: PUR <b>Part No.: 65000307</b>
Sensor connector M12 × 1 angled	With angled socket M12×1 and plastic interlock Part No.: 61703220
Sensor connector M12 × 1 straight	With straight cable connector M12 × 1 and plastic interlock <b>Part No.: 61703221</b>

<b>Clamps</b>	
Sensor clamp	Plastic design, Material: Polyamide, Color: black Fixing: for 2 × M5 <b>Part No.: 61703219</b>
Sensor clamp	Design: rubber-coated stainless steel pipe clamp Mounting hole Ø 8,4 mm <b>Part No.: 61703218</b>

### 8.2 Disposal

Depending on the material, the parts must be disposed of in an expert way.



**ENVIRONMENTALLY  
FRIENDLY  
DISPOSAL**

All units can be disposed of through Netter GmbH.  
The valid disposal prices are available on request.

### 8.3 Enclosures

**Enclosure(s):**

Declaration of Conformity



Further information available on request:  
**Leaflet No. 38 and others**