



These operating instructions apply to:

- NHG 500 L
- NHG 600 R L
- NHG 900 L
- NHG 3000 L
- NHG 6000 L



NHG 500 L to NHG 900 L



NHG 3000 L



NHG 6000 L

Contents

1	GENERAL NOTES	3
2	SAFETY	5
3	TECHNICAL DATA	7
4	DESIGN AND FUNCTIONING	9
5	TRANSPORT AND STORAGE	10
6	INSTALLATION	11
7	START-UP / OPERATION	15
8	MAINTENANCE, REPAIR	16
9	TROUBLESHOOTING	17
10	SPARE PARTS	18
11	ACCESSORIES	18
12	DISPOSAL	19
13	ENCLOSURES	20

Scope of delivery

As a rule, the NHG L are delivered with the following components:

- Hydraulic vibrator NHG L
- Operating instructions
- Packaging

Please refer to your delivery note for any changes in the scope of delivery.

Check the packaging for possible signs of transport damage.

In the event of damage to the packaging, check that the contents are complete and undamaged. If there is any damage, inform the shipping agent. Compare the scope of the delivery with the delivery note.

1 General Notes

Information on the operating instructions

Use and storage of the operating instructions

Before using the hydraulic vibrators of the series NHG L read this operating manual carefully. It is the basis for any action taken with regard to the NHG L and may be used for training purposes. The operating instructions must be kept close to the product after having been read.

Target group

The target group for these operating instructions is qualified technical personnel from the mechanical engineering sector who have a basic knowledge of hydraulics and mechanics.

Installation, commissioning, maintenance, fault elimination and disassembly of the NHG L must only be performed by persons who have been instructed in the correct use of the units.

Personnel who have not been instructed accordingly are not permitted to work on the NHG L.

.

Copyright

This documentation is subject to copyright. All rights e.g. for translation, photo-mechanical reproduction, printing or reproduction (e.g. data processing, data carriers and data networks) of these operating instructions, or parts thereof, are strictly reserved to **NetterVibration**.

Limitation of liability

All technical information, data and instructions on installation, operation and maintenance in these operating instructions are based on the latest information available at the time of printing and take into account our past experience to the best of our knowledge.

No claims can be derived from the information, illustrations and descriptions in these operating instructions.

The manufacturer does not accept any liability for damages due to:

- failure to observe the operating instructions
- improper use
- unauthorized repairs
- technical modifications
- use of unauthorized spare parts

Translations are made to the best of our knowledge. **NetterVibration** does not accept any liability for translation errors, even if the translation was made by us or on our behalf. Only the original German text is binding.

The following information and hazard symbols are used in these operating instructions.

	DANGER	Indicates a possible danger that can lead to death or physical injury if not avoided.
	WARNING	Indicates a possible danger that can lead to physical injury and/or damage to property if not avoided.
	DO NOT TOUCH!	Indicates a possible danger that can lead to physical injury if not avoided.
	WEAR EAR PROTECTION	Indicates a possible danger that can lead to physical injury if not avoided.
	IMPORTANT	Instruction with particularly useful information and tips.
	ENVIRONMENTAL HAZARD	Escaping hydraulic oil (leakage) can cause environmental damage. Implement measures to prevent hydraulic oil from escaping to the environment.
	ENVIRONMENTALLY FRIENDLY DISPOSAL	Refers to the obligation of an environmentally-friendly disposal.

Information about the NHG L

The hydraulic vibrators of the series NHG L comply with the EC Machinery Directive 2006/42/EC.

In particular the standard DIN EN ISO 12100 has been complied with.

Special features

- Circular vibrations
- Frequency infinitely adjustable via volume flow

2 Safety

Designated use:

The hydraulic vibrators are intended for installation in machines. These machines use hydraulic vibrators for emptying containers, especially for transport vehicles, e.g. trucks, silo buses and ships. Any other use is considered improper use.

Qualification of the personnel:

Assembly, commissioning, maintenance and repair of the vibrators must be performed only by authorized qualified personnel.

Any handling of the hydraulic vibrators lies within the responsibility of the operator.

Accessories which ensure the correct operation and safety must provide a protection type required for the specific use.



WARNING

Netter GmbH does not assume liability for injury or damage resulting from technical modifications to the product or failure to observe the instructions and warnings in this operating manual.



WARNING

Source of danger:

Faulty hose connections

Possible consequences of non-observance:

A hose coming loose when under pressure can cause injuries.

Avoiding the danger:

The hose lines must be securely connected. The connections must be regularly checked and the screw connections tightened if necessary.

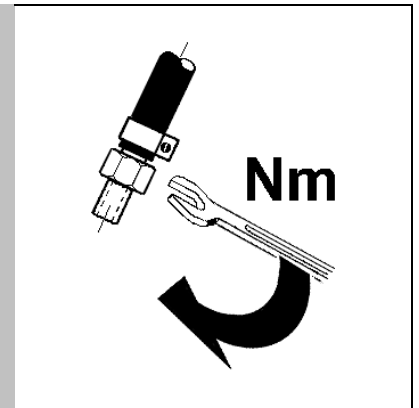

WARNING

Source of danger:

NHG L vibrators work with hydraulic pressure.

Possible consequences of non-observance:

A hose coming loose when under pressure can cause injuries.

Avoiding the danger:

When working on the NHG L, ensure that the hydraulic aggregate is switched off.



Source of danger:

Hydraulic vibrators, parts of the construction and hydraulic connections can become loose due to the vibrations.

Possible consequences of non-observance:

Falling parts can cause damage to persons and equipment.

Avoiding the danger:

Screw locking media and/or Loctite, etc. must be used. Screw connections and hydraulic connections must be checked after one hour of operation and then regularly (usually every month) and tightened if necessary.

To fasten the NHG L, we recommend using the Netter fastening sets NBS.

In critical installation situations the vibrator has to be secured by means of a steel rope.

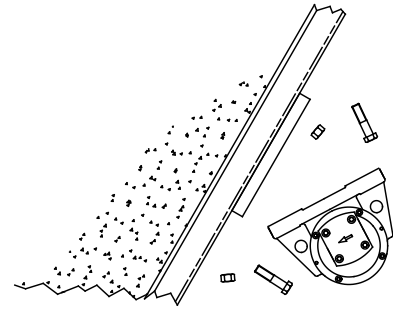

Source of danger:

The noise level can exceed 85 dB(A) in the vicinity of the hydraulic vibrator or in the vicinity of constructions connected to the vibrator.

Possible consequences of non-observance:

The human ear can be permanently damaged by the high noise level.

Avoiding the danger:

Ear protection is required when working in noisy areas where 85 dB(A) is exceeded.



WEAR EAR PROTECTION



Source of danger:

The surface temperature of the NHG L vibrators can reach temperatures > 80°C during operation.

Possible consequences of non-observance:

There is a danger of burning.

Avoiding the danger:

The vibrators must not be touched during operation or shortly after being switched off.



3 Technical Data

Type	Working torque [cmkg]	Normal operation ED 100%			Brief operation ED ≤ 60%			Weight [kg]
		Frequency [U/min]	Centrifugal force [N]	Oil requirement [l/min]	Frequency [U/min]	Centrifugal force [N]	Oil requirement [l/min]	
NHG 500 L	2,06	6.000	4.070	12	7.000	5.550	14	6,4
NHG 600 R L**	0 bis 3	6.000	5.922	12	7.000	5.723*	14	8,2
NHG 900 L	6,64	4.000	5.870	8	5.000	9.100	10	7,7
NHG 3000 L	29,18	3.500	19.600	20	4.000	25.600	22	29,0
NHG 6000 L	124,00	3.000	61.206	48	—	—	—	78,0

*) The working torque must be reduced to 2,19 cmkg.

***) See table for adjustment of unbalances page 12.

Admissible operating conditions

Drive medium:

Clean hydraulic oil DIN 51524/25 or motor oil DIN 51511

Viscosity range:

13 to 200 mm²/s

Recommended range: 15 to 45 mm²/s

Filtering:

≤ 10 µm, NAS 1638 class 10, ISO/DIS 4406 class 19/16

Tank ventilation filter: ≤ 10 µm

Permitted speed for continuous operation:

NHG 500 L, NHG 600 L: max. 6000 min⁻¹

NHG 900 L: max. 4000 min⁻¹

NHG 3000 L: max. 3500 min⁻¹

NHG 6000 L : max. 3000 min⁻¹



IMPORTANT

Maximum permitted operating pressures:

Type	Pressure side	Leakage oil line
NHG 500 L	200 bar*	1 bar
NHG 600 R L		
NHG 900 L		
NHG 3000 L	250 bar*	
NHG 6000 L	210 bar*	

Ambient temperature:

NHG -20°C to 40°C*

Lubrication:

NHG 500 L to NHG 900 L: Life-time lubricated deep groove ball bearing

NHG 3000 L and NHG 6000 L: Oil mist lubrication with SAE 22

*) Higher operating pressures and temperatures are only possible after consultation and written approval by the application technicians of Netter GmbH.

NHG 500 L, NHG 900 L, NHG 3000 L and NHG 6000 L have permanently set working torques.
Adjustable unbalance and larger vibrator types on request.
Speed and centrifugal force can be adjusted via the oil flow.

The type NHG 600 R L (reversible) has a working torque which can be set in seven steps. The unbalance can be adjusted from the outside, it is not necessary to open the cover.

Type designation

The type designations of the hydraulic external vibrators NHG L have the supplement L. The letter shows that the drive is equipped with a leakage oil bore (optionally available without leakage oil connection).

Sound level:

The sound level is below 80 dB(A).
Depending on the application a sound level > 85 dB(A) can be reached.

Dimensions:

NHG 500 L, NHG 600 R L and NHG 900 L

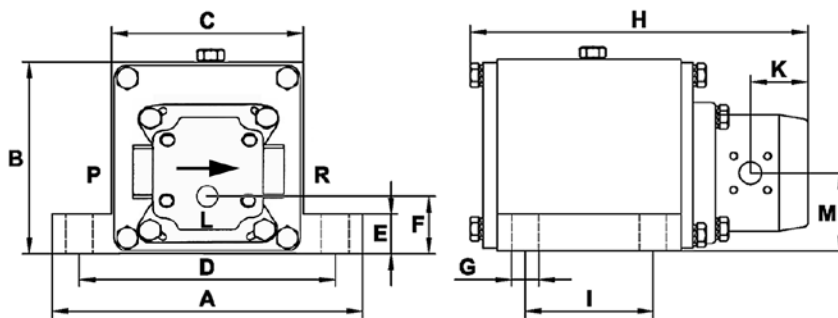

NHG 3000 L and NHG 6000 L

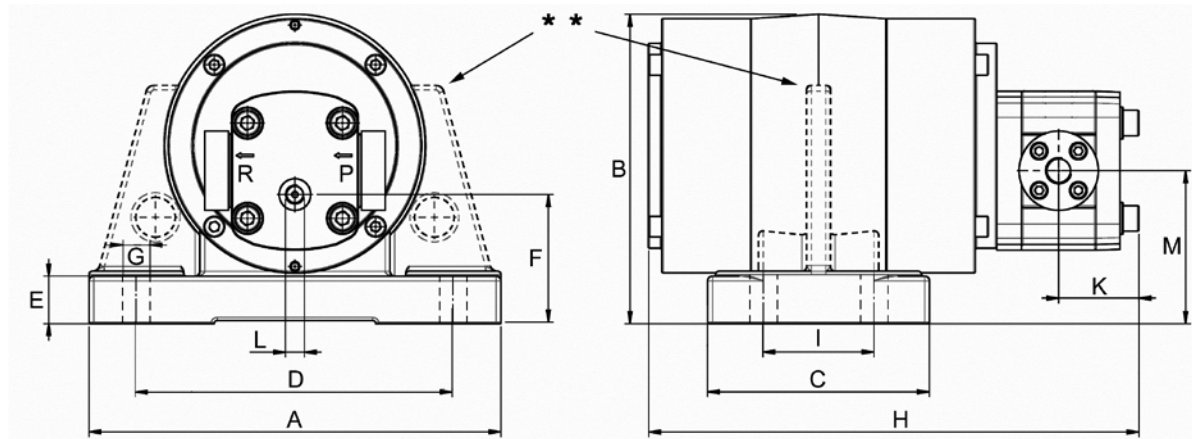

***Lateral ribs of the NHG 3000 L

Type	A [mm]	B [mm]	C [mm]	D [mm]	E [mm]	F [mm]	Ø G [mm]	H [mm]	I [mm]	K [mm]	Ø L [mm]	M [mm]	Ø P	Ø R
NHG 500 L NHG 600 R L NHG 900 L	194	120	120	160	25	36	17	213,5	80	36,5	G1/4	49	G1/4	G3/8
NHG 3000 L	260	195	140	200	30	80	17	310	70	50	M12×1,5	96	G3/8	G3/8
NHG 6000L	345	260	213	300	58	128,5	22	400	60	59	M12×1,5	113	G3/8	G3/8

4 Design and Functioning

The hydraulic external vibrators of the series NHG L have a shaft with an eccentrically applied weight driven by a hydraulic motor.

The rapidly rotating unbalance weight (adjustable in 7 steps in the type NHG 600 R L) generates high centrifugal forces.

The NHG L external vibrator essentially consists of a housing with a shaft rotating in radial bearings and the unbalance attached to the middle of the shaft. The motor flange is used to hold the hydraulic motor.

The over-dimensioned shaft bearings are suitable for heavy loads and high speeds.

The housings of the vibrators NHG 500 L to NHG 900 L are made of an aluminium alloy.

The housings of the NHG 3000 L and NHG 6000 L are made of high-strength spheroidal cast iron.

The end shields and the housing of the hydraulic drive are made of aluminium.

The hydraulic drive shafts and the unbalance are made of alloyed hardened steel.

5 Transport and Storage

The units are packed ready-to-install. The type plate is attached to the hydraulic external vibrator.

Accessories and add-on parts are delivered loosely, unless otherwise agreed.

Particular transport conditions are not required.

The unit should be stored in a clean and dry environment.

Screw the hydraulic external vibrator to a plate before operation.

The storage temperature can be -30°C to 60 °C.

(This does not apply to the operating temperature, see chapter 2, page 6 and chapter. 3 „Technical Data”, page 7).

6 Installation



Ensure that the hydraulic aggregate is switched off and secured against being switched on unintentionally during installation or when working at the hydraulic external vibrator or the supply lines.

Installation of hydraulic external vibrators:



The Netter hydraulic external vibrators can be mounted in any position.

The hydraulic external vibrators NHG L are screwed on to reinforcing profiles (U-shaped profile with mounting plate).

Ensure tension-free mounting of the unit during installation.

The mounting plate must be absolutely even!

Only tighten fastening screws when motor flange fits closely.

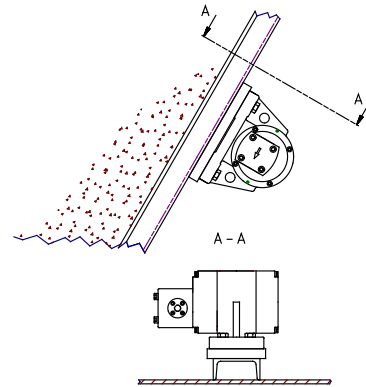

Bear in mind already when mounting the vibrator that the admissible temperature range must not be exceeded during operation, see chapter 2, "Safety". Versions for other temperature ranges on request.



Use self-locking nuts or a liquid locking agent to prevent loosening. The tightening torques can be taken from the following table. Higher tightening torques may cause fracture of screws or tearing of threads. Inadequate screw connections may cause loosening of vibrators by vibration. This can result in damage to persons and material!



In critical installation situations the unit must be secured with a steel rope.



Recommended average tightening torques for fastening screws of strength class 8.8 (screws as supplied, without additional lubrication):

Type	Thread/hole pattern (mm)	Tightening torque
NHG 500 L, 600 L u. 900 L	M 16 / 160 × 80	190 Nm
NHG 3000 L	M 16 / 200 × 70	190 Nm
NHG 6000 L	M 20 / 300 × (2 × 60)	380 Nm

Adjusting the working moment at the NHG 600 R L:

Remove the hexagon screw 4 with O-ring and protective plug 7 from the housing.
 Turn the shaft 1 using the socket wrench 2 until the allen key 5 fits into the bore of the unbalance 6.
 Loosen the hexagon socket screw 3 and unscrew it by approx. four turns.
 The socket wrench 2 remains in place until the unbalance 6 is locked.

Turn the shaft 1 to the required position (pos. 1 to 7, table) using the socket wrench 2.
 Turn the allen key 5 clockwise, thus moving the shaft 1 a few mm back and forth until you feel the fixing bore in the shaft 1. Screw the hexagon socket screw 3 into the shaft by four turns and tighten it (15 Nm).
 Screw the hexagon screw 4 with O-ring and protective plug 7 into the housing.

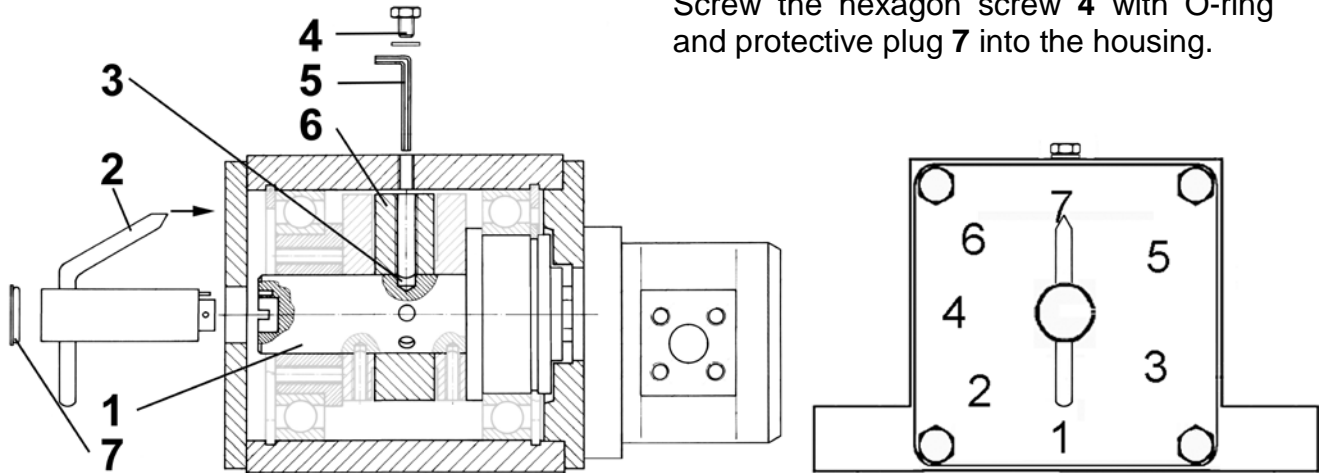

- 1 Shaft
- 2 Socket wrench
- 3 Hexagon socket screw
- 4 Hexagon screw
- 5 Allen key
- 6 Unbalance
- 7 Protective plug

Vibrator type NHG 600 R L (reversible) has a working torque which can be adjusted in seven steps.

Pos.	Unbalance adjustment		Working moment [cmkg]	Centrifugal force [N]	
	[%]	[∠°]		6000 min ⁻¹	7000 min ⁻¹
1	17,0	160	0,52	1.026	1.397
2	38,3	135	1,15	2.270	3.090
3	50,0	120	1,50	2.961	4.030
4	70,6	90	2,13	4.205	5.723
5	86,6	60	2,60	5.133	6.986
6	92,0	45	2,80	5.528	7.523 *)
7	100,0	0	3,00	5.922	8.061 *)

*) Speeds above 7000 min⁻¹ and centrifugal forces exceeding 6000 N lead to increased wear on the bearing and shaft gasket..



To ensure problem-free operation, it is necessary to keep the degree of contamination of the oil at an acceptable level. The recommended degree of contamination is 19/16 (see ISO 4406).



Escaping hydraulic oil (leakage) can cause environmental damage. Implement measures to prevent hydraulic oil from escaping to the environment.

Standard installations for hydraulic external vibrators of the series NHG L



Use only hose lines to connect the NHG L vibrators! Pipes can fracture if used. The hose lengths must be as short as possible and as long as is necessary, but not longer than 10m.
The permitted direction of rotation (P → R) must be complied with during installation of the hose lines!

Commercial control valves (2/2-way, 4/2-way, etc.) or ball valves can be used for actuation.

The components used must be approved for the drive media and system pressure.

Do not abruptly start or brake the hydraulic vibrators as this might lead

to premature wear of the motor shaft, coupling and vibrator shaft.

We recommend the use of a progressive control valve for actuation. A bypass line should be laid for frequent switching on and off to prevent the generation of a vacuum in the supply line by the geared motor.

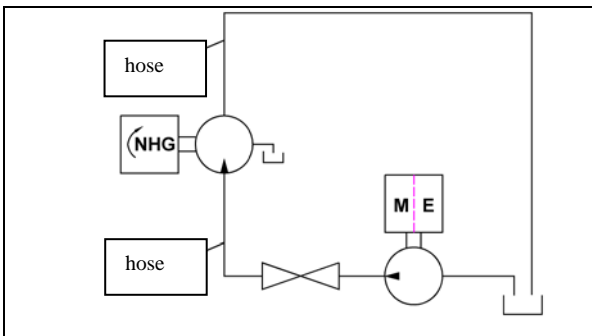

Actuation option for a hydraulic external vibrator with leakage oil connection. Actuation possible via ball valve or 2/2-way valve.

Attention:
Do not exceed the maximum delivery volume. There is a danger of overloading the NHG L (see Chap. 3, page 7, Technical Data).

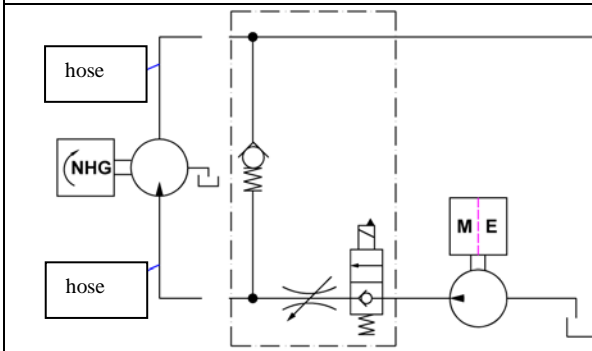

Actuation option for a hydraulic external vibrator with leakage oil connection, bypass line, flow regulating and control valve for high pulse frequencies.

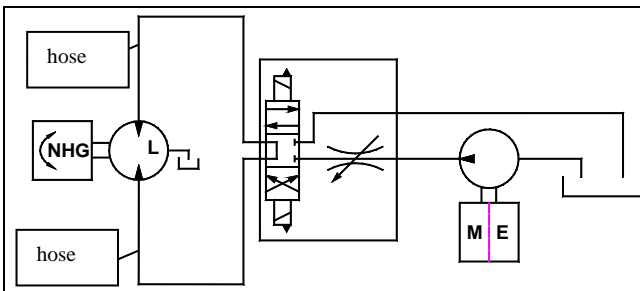

Actuation option for a hydraulic external vibrator with leakage oil connection, flow regulating and control valve for high pulse frequencies and two rotation directions.

Connection data

Type	Pressure side		Return		Leakage oil line	
	Thread	DN [mm]	Thread	DN [mm]	Thread	DN [mm]
NHG 500 L	G 1/4	8-12	G 3/8	12-15	G 1/4	8
NHG 600 R L	G 1/4	8-12	G 3/8	12-15	G 1/4	8
NHG 900 L	G 1/4	8-12	G 3/8	12-15	G 1/4	8
NHG 3000 L	G 3/8	12-15	G 3/8	15-18	M12x1,5	8
NHG 6000 L	G 3/8	12-15	G 3/8	15-18	M12x1,5	8

Check list for installation:

- 1) Observe expected operating temperature.
- 2) Tighten fastening screws for NHG L.
- 3) Mount the control valve, flow regulating valve, feed and return lines and bypass line.
- 4) Check!
 - Rotation direction of hydraulic motor observed?
 - Hose line connections tightened?
 - Nominal width data observed?
 - Device secured against falling down?

7 Start-up / Operation

Flushing:

Before initial operation, residues of the corrosion protection or contamination incurred during transport and storage must be removed by flushing with the hydraulic fluid to be used.

Filter:

During the start-up phase, use a filter
⊗ 5µm for 2-3 hours, then use a filter
⊗ 10µm (19/16 ISO 4406).

Leakage oil connection:

The leakage oil line must be laid with a sufficient dimension and should end in a container below the liquid level so that the device remains filled without a siphon effect occurring in the container.

Direction of rotation:

Hydraulic external vibrators with leakage oil connection can be used for both rotation directions.

Hydraulic external vibrators without leakage oil connection only have one permitted direction of rotation.

The direction of rotation can only be changed by **NetterVibration**.

Controlling the speed:

The speed can only be controlled by external actuation using an adjustable flow regulating valve.

See actuation options, Chap. 6 Installation, page 13.



WARNING

Note:

To protect the vibrators against excessive speeds, the flow rate must be limited to the maximum permissible volume with a flow regulating valve (see delivery volumes).

To monitor this, check the frequency with a sirometer.



DANGER

When using adjustable flow regulating valves for overload protection and frequency control, the maximum delivery volume must not be exceeded (danger of device overloading).

When using static flow regulating valves, the presetting must be set to the maximum permissible delivery volume of the hydraulic external vibrator.

Check list for start-up:

- 1) Check the hose connections before switching on.
- 2) If necessary, set required speed on the flow regulator.
- 3) Observe parameters, in particular the max. speeds and max. pressures.
- 4) After the lines and vibrators are filled, the suction line of the pump must remain sufficiently deep below the liquid level.



DANGER

Retighten or check the fastening screws after one hour of operation. The fastening screws should then be regularly checked (normally every three months) and tightened if necessary.

8 Maintenance, Repair



Ensure that the hydraulic aggregate is switched off and secured against unintended start-up during installation or when working on the hydraulic external vibrator and the supply lines.



Important: All maintenance work must be carried out in a clean environment.

Avoid pollution through hydraulic oils. Escape of oil must be avoided during all work on the hydraulic aggregates. Escaping oil must be collected in suitable containers and disposed of (via the supplier).

Maintenance schedule



Screw connections	Screw connections must be checked after one hour of operation (after the initial start-up) and then on a regular basis, tightened and secured with Loctite when necessary.
Oil change:	After approx. 1.000 operating hours if subjected only to vibration drives. If additional motors or cylinders are used, depending on the utilisation, approx. 500 to 800 operating hours. Check the oil level and the filter unit on the hydraulic aggregate.
Hydraulic lines	Check for free flow and kinks. If necessary, clean and remove kinks.
Filter	Replace the filter insert.

Recommended average tightening torques for screws strength class 8.8 at cover and hydraulic motor:



Hydraulic vibrator	Thread	Tightening torques
Locking screw and cover	M 8	23 Nm
Motor fastening and flanges	M 10	49 Nm



The maintenance intervals essentially depend on the operating time and the purity of the drive medium.

Maintenance and repair work on the hydraulic external vibrators will be carried out by Netter GmbH.

NHG L series hydraulic external vibrators are equipped with geared motors. Hydro-geared motors usually do not require maintenance.

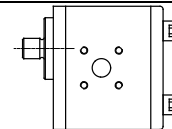

Lubrication NHG 500 L, NHG 600 R L and HG 900 L:

The bearings have life-time lubrication.

In case of war they have to be replaced (service life depends on speed, cycle time, temperature and impacts).

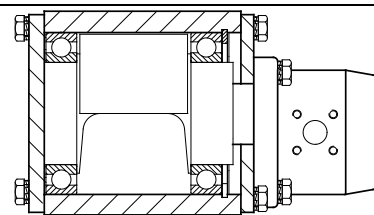

Oil change Lubricating oil in NHG 3000 L and NHG 6000 L:

NHG 3000 L and NHG 6000 L have roller bearings that are lubricated with an oil mist. The lubricating oil in the NHG L should be replaced after approx. 1,000 operating hours. At that time, the bearing should be checked for wear and replaced if necessary.

Lubricating oil volume for roller bearing oil mist:

NHG 3000 L approx. 150 cm³

NHG 6000 L approx. 400 cm³.

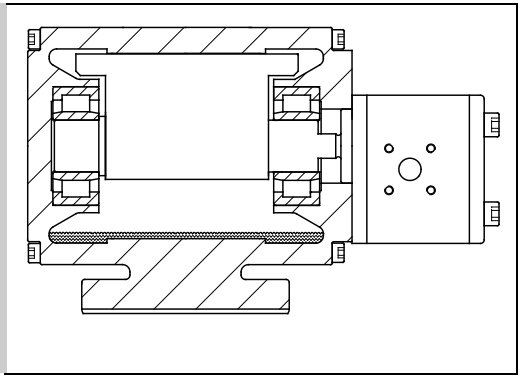

9 Troubleshooting

Malfunction	Possible causes	Remedy
No power. Unbalance housing is filled with drive medium. Premature wear on the motor shaft gasket.	Pressures in tank or leakage oil lines too high. (see Chap. 3 Operating pressure and temperature)	Replace motor shaft gasket.
	Speed too high, therefore delivery volume too high. (see Chap. 3 Technical Data)	Replace motor shaft gasket.
Premature wear on the unbalance bearing.	Speed too high, therefore delivery volume too high. (see Chap. 3 Technical Data)	Replace motor shaft gasket

10 Spare Parts

When you order spare parts, please state the following:

1. Type of device
2. Description and position of spare part
3. Quantity required

11 Accessories

The following accessories are available (on request) for NHG L vibrators:

Description	Comment
"Static" flow regulating valve	Limits the volume flow to the permitted delivery flow rate of the hydraulic external vibrator. (Overload protection)
"Adjustable" flow regulating valve	Speed regulation of the hydraulic external vibrator.
Directional valves	Switch the hydraulic external vibrators on and off.
Electronic timers	Specification of cycle times (duty and pause time) for hydraulic external vibrators.
Safety suspensions	Clamp with steel cable and spring clip, see Chap. 2, p. 6.

12 Disposal

The parts must be disposed of correctly in accordance with the material.

Material specifications:

- Housing,
NHG 500 L to NHG 900 L ⇒ Aluminium
NHG 3000 L, NHG 6000 L ⇒ Grey cast iron
- Unbalance, shaft, bearing, screws,
(flanges, cover NHG 6000 L) ⇒ Steel
- Hydraulic motors ⇒ Steel and aluminium
- Gaskets ⇒ PTFE, NBR, VITON
- Flanges, cover ⇒ Aluminium



Escaping hydraulic oil can cause environmental damage.
Implement measures to prevent hydraulic oil from escaping to the environment.



All devices can be disposed of via Netter GmbH.
You will be given the applicable disposal prices on request.

13 Enclosures

Enclosure(s):

Declaration of incorporation



Further information available on request: Brochure No. 32 (NHG L), Spare part list, etc.