



NetterVibration

Installation and Operating
Instructions for Netter
Electric External Vibrators



April 2014
BA No. 1395EN
Page 1/24

These operating instructions apply to: **Series NEA**
Series NED
Series NEG



Netter GmbH
www.**NetterVibration.com**

Germany
Fritz-Ullmann-Straße 9
55252 Mainz-Kastel
Tel. +49 6134 2901-0
info@**NetterVibration.de**

Poland
Al. W. Korfanteo 195/17
40-153 Katowice
Tel. +48 32 2050947
info@**NetterVibration.pl**

Switzerland
Erlenweg 4
4310 Rheinfelden
Tel. +41 61 8316200
info@**NetterVibration.ch**

Spain
Errota Kalea 8
20150 Villabona-Guipúzcoa
Tel. +34 943 694 994
info@**NetterVibration.es**

Table of Contents

1	GENERAL NOTES	3
2	SAFETY	6
3	TECHNICAL DATA	7
4	DESIGN AND FUNCTION	9
5	TRANSPORT AND STORAGE	10
6	INSTALLATION	10
6.1	Mounting of the vibrators	11
6.2	Electrical connection	12
7	START-UP	15
8	ADJUSTMENT OF UNBALANCES	16
9	TROUBLE SHOOTING	19
10	SERVICE / MAINTENANCE	20
11	SPARE PARTS	23
13	DISPOSAL	24
14	ENCLOSURES	24

Scope of delivery

As a rule, the NEG are delivered with the following components:

- Electric external vibrator (NEG)
- Operating instructions
- Packaging

For changes to the scope of delivery see delivery note.

Check the packaging for possible signs of transport damage.

In the event of damage to the packaging, check that the contents are complete and undamaged. If there is any damage, inform the shipping agent. Compare the scope of the delivery with the delivery note.

1 General notes

Information on the operating instructions

Use and storage of the operating instructions

Before using the electric external vibrators of the series NEG read this operating manual carefully. It is the basis for any action taken with regard to the NEG and may be used for training purposes. The operating manual should subsequently be stored near the NEG.

Target group

The target group for these operating instructions is qualified technical personnel from the mechanical engineering sector who have a basic knowledge of electrics and mechanics.

Installation, commissioning, maintenance, fault elimination and disassembly of the NEG must only be performed by persons who have been instructed in the proper handling of the units.

Persons who have not been instructed accordingly must not carry out any works on the NEG.

Copyright

This documentation is subject to copyright. All rights e.g. for translation, photo-mechanical reproduction, printing or reproduction (e.g. data processing, data carriers and data networks) of this operating manual, or parts thereof, are strictly reserved to **NetterVibration**.

Limitation of liability

All technical information, data and instructions on installation, operation and maintenance in these operating instructions are based on the latest information available at the time of printing and take into account our past experience to the best of our knowledge.







No claims can be derived from the information, illustrations and descriptions in these operating instructions.

The manufacturer does not assume liability for damages resulting from:

- failure to observe the operating instructions
- improper use
- unauthorized repairs
- technical modifications
- use of inadmissible spare parts

Translations are made to the best knowledge. **NetterVibration** does not assume liability for translation errors, even if the translation was made by us or on our behalf. Only the original German version is binding.

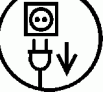
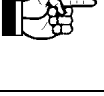
The following instruction and warning symbols are used in this operating manual:

	<p>DANGER OF EXPLOSION</p>	<p>indicates a possible explosion which can result in death or personal injury if the instruction is not followed.</p>
	<p>DANGER</p>	<p>indicates a possible danger which can result in death or personal injury if the instruction is not followed</p>
	<p>WARNING</p>	<p>indicates a possible risk which can result in personal injury and/or material damage if the instruction is not followed.</p>
	<p>HOT SURFACE</p>	<p>indicates a possible danger which can result in personal injury and/or material damage if the instruction is not followed.</p>
	<p>DISCONNECT POWER SUPPLY</p>	<p>indicates a possible danger which can result in personal injury and/or material damage if the instruction is not followed.</p>
	<p>IMPORTANT</p>	<p>note with especially useful information and tips.</p>
	<p>ENVIRONMENTALLY FRIENDLY DISPOSAL</p>	<p>indicates the obligation of an environmentally friendly disposal.</p>

Information on NEA, NED and NEG

Netter electric external vibrators of the series NEA, NED and NEG comply with the EC machinery directive 2006/42/EC, the electromagnetic compatibility directive 2004/108/EC and the low voltage directive 2006/95/EC.

In particular, the standards DIN EN ISO 12100, DIN EN 60529 and EN 60034-1 have been complied with.

From housing size 100 upwards, the electric external vibrators of the series NEA and NEG also comply with directive 94/9/EC for device group II and are suitable for use in potentially explosive areas of category 2D in the zones 21 and 22 (LCIE 07 ATEX 6015 X). In particular, the standards DIN EN 61241-0 and 61241-1 have been complied with.

Special features:

- Adjustable centrifugal force
- All vibrators are impregnated for tropical use by vacuum casting or by trickle impregnation.
- 100% duty cycle
- Degree of protection IP 66 (EN 60529), housing size 50 and 60: degree of protection IP 65
- Insulation class F
- High rate of efficiency due to silicon electrical sheets
- Terminal box integrated in housing foot
- (housing size 101 to 120)
- Smallest mounting dimensions
- Stainless steel end covers
- Sound level measured in the open ≤ 70 dB(A) acc. to IEC
- From housing size 170 onwards, equipped with PTC thermistors by default
- Earthing screw on housing and in terminal box

2 Safety

Intended use:

The vibrators are intended for installation in machines according to the device group and the device category. These machines use vibrations for sieving, loosening, conveying, compacting and separation of bulk materials.

Any other use is considered improper use.

There are no built-in safety devices.

Qualification of the personnel:

Assembly, commissioning, maintenance and repair of the vibrators must be performed only by authorized qualified personnel.

Any handling of the electric vibrators lies within the responsibility of the operator.

Accessories which ensure the correct operation and safety must provide a protection type required for the specific use.



Netter electric external vibrators generate vibrations.

The operator of vibration systems has to protect his employees from actual or potential threats to their health and safety due to vibrations.



Netter GmbH does not assume liability for injury or damage resulting from technical modifications to the product or failure to observe the instructions and warnings in this operating manual.



Live parts can cause severe or even fatal injury.

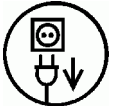

When working on the vibrators these must be isolated from the mains supply.

To do so please proceed as follows:

1. Switch off vibrator
2. Secure against switching on unintentionally
3. Make sure it is deenergized



The vibrators must not be touched during operation or shortly after being switched off. The surface of the vibrators may become very hot during operation so that there is a risk of burning.

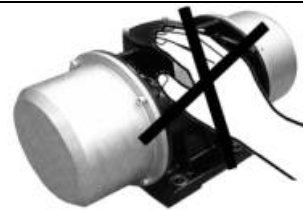

The electric external vibrators are built in accordance with the latest EC directives.

Before using these vibrators in hazardous dusty areas, the operator must ensure that there is no risk of explosion due to the introduction of vibration energy.

The installation and operation of the vibrators is to be carried out in accordance with the ATEX regulations for operation in potentially explosive environments, the requirements of the local electrical engineering associations (e.g. VDE) and the known accident prevention rules.

3 Technical Data

Admissible operating conditions

Mains voltage and frequency:

Mains voltage and mains frequency must comply with the mains voltage and frequency indicated on the type plate.

Series NEA and NEG:

Voltage and frequency see details on type plate.

Series NED: direct current 12 V or 24 V

Power supply by means of:

- fixed voltage and frequency or
- frequency converter

The operation of three-phase vibrators of the series NEG with frequency converters allows rotary speeds of > 3000 rpm.

If the electric external vibrators are operated with a frequency converter, compliance with the EMV directive has to be ensured.

In zones 21 and 22 the frequency converter may regulate the frequency between 20 Hz and 50 Hz or 20 Hz and 60 Hz (please check max. frequency on type plate) at a constant torque load (linear Volt-Hertz-curve).

Rotary speed ranges:

2-pole 3000 rpm 50 Hz / 3600 rpm 60 Hz

4-pole 1500 rpm 50 Hz / 1800 rpm 60 Hz

6-pole 1000 rpm 50 Hz / 1200 rpm 60 Hz

8-pole 750 rpm 50 Hz / 900 rpm 60 Hz

Direct current 3000 rpm or 3600 rpm

Admissible ambient temperature:

-20°C to 40°C or

-20°C to 55°C

The maximum ambient temperature specified on the type plate must not be exceeded.

These values are valid for operation with an ON-period of 100%.

Cycled or frequency-controlled operation or synchronous operation are subject to specific requirements. These must be clarified with **NetterVibration** for each individual case.

These electric vibrators must not be used in environments with a highly explosive gas atmosphere.

Thermal protection:

By default, from housing size 170 upwards with thermistors type PTC 130°C. For smaller vibrators available as first equipment on request.

If the vibrator is operated in environments containing explosive dust (zone 21 and 22), it is mandatory to connect the PTC-thermistor. This regulation does not apply if the unit is not equipped with a PTC-thermistor.

Sound level:

Depending on type ≤ 70 dB(A)

The sound level is determined to a great extent by the surface upon which the vibrator is mounted (e.g. sheet metal). The sound level will be amplified by non-silenced sheet metal.

*) Higher temperatures are only possible after consultation of and written approval from the application technicians of Netter GmbH.



Please refer to the type plate for the technical data of your electric external vibrator.

		NetterVibration Germany, 55252 Mainz-Kastel Tel.: +49 6134 2901-0			
Type designation	⇒	Type		Duty	%
Rotary speed	⇒	n	min ⁻¹	Fc	N
Voltage	⇒	U	V	f	Hz
Current	⇒	I	A	P	kW
Phases	⇒	Ph		Iso.Cl.	
Serial number	⇒	No.		Prot.	
					⇐
					⇐
					⇐
					⇐
					⇐
					⇐
					⇐

		NetterVibration Germany, 55252 Mainz-Kastel, Tel.: +49 6134 2901-0			
		0722 II 2 D		tD A21 IP66 T 125 °C	
Type designation	⇒	Type	LCIE 07	Duty	100 %
Voltage	⇒	U	ATEX 6015 X	Fc	N
Current	⇒	I		n	min ⁻¹ f Hz
Phases	⇒	Ph		P _{in}	kW
capacity	⇒	Cap.	EN 60034-1	P _{out}	kW
Power factor	⇒	cos φ		Ins.Cl.	F Prot. IP66
Year of manufacturing	⇒	Year	216102	Max. Amb.	40 °C
Serial number	⇒	No.			
				MAY BE USED WITH PWM INVERTER - CT- 20 HZ TO BASE FREQUENCY	
				CAUTION: USE SUPPLY WIRE SUITABLE FOR 105 °C	

For detailed technical data of vibrators please refer to the tables in the middle section of these operating instructions (removable).

4 Design and Function

- **The electric motor** for the series NEA and NEG is an asynchronous motor, for series NED it is a DC motor.
 - To achieve a high rate of efficiency at a low temperature of the motor, the stators of the asynchronous motors are made of electric sheet steel with a low dissipation factor.
 - The vacuum resin cast stators are a particular quality feature. The dried resin bonds housing and stator together to form an inseparable unit, which is robust and tropical proof. From housing size 140 onwards the stators are trickle impregnated. With this method the spaces between the individual windings are completely filled and a vibration resistant seating of the complete unit is achieved.
 - Motor protection by incorporated PTC-thermistor 130°C, by default from size 170 onwards (DIN 44081 und DIN 44082).
 - Protection by housing “tD” for use in areas with explosive dust atmosphere.
- **The motor shaft** is made of heat treated round alloy steel.
- **The special bearings** are over-dimensioned for excessive loads and high speeds.
- All units are suitable **for speed regulation** with frequency converters.
- **The housing** of sizes 50 to 140 and 160 are made of an aluminium alloy.
- **The housing** of sizes 150 and 170 to 210 are made of high-tensile nodular cast iron.
- Due to powder coating **the paint finish** is highly weather resistant as well as resistant against abrasion, impacts and a wide variety of chemicals.
Colour: traffic black.
- **The unbalance masses** are adjustable as follows:
 - Type XS continuously adjustable
 - Type XM in 10% steps
 - Type XLs in 20° steps
 - Type XL by removable discs
- **The covers of the unbalances** are made of stainless high-grade steel.

5 Transport and Storage



IMPORTANT

Check the packaging for possible shipping damage. If damage to the packaging is found check the content for completeness and possible damage. In case of damage inform the forwarding agent.

The units are packed ready for installation. The type plate is attached to the vibrator. If not specified differently the vibrator is delivered with an unbalance setting of 100%.

When transporting the vibrator make sure to avoid hard impacts or vibrations which could damage the bearings.

The unit should be stored in a clean, dry environment.

If the vibrator needs to be in storage for a longer period of time (2 years max.), the temperature in the store must not fall below -30°C or above $+60^{\circ}\text{C}$ and the relative air humidity must not exceed 60%.



EXPLOSION
HAZARD

If the vibrator is operated in areas with explosive dust (zones 21 and 22), a maintenance by **NetterVibration** is compulsory in case the unit was kept on stock for more than a year



WARNING

The transport eyes must solely be used to lift the vibrator.

If the vibrator is fitted with two transport eyes, both of these should be used for lifting. The lifting angle must not exceed 45° .



6 Installation



IMPORTANT

The installation of the vibrators must only be carried out by authorized, qualified personnel. The qualified personnel must use only tools, which are suitable for the application.



IMPORTANT

During installation please comply strictly with the safety regulations in chapter 2 and the accident prevention rules! Installation of the system must be performed in compliance with the local, applicable regulations (e.g. VDE-regulations).

6.1 Mounting of the vibrators

Netter electric external vibrators can be operated in any position. During installation the following notes must be strictly observed:



CAUTION

The mounting surfaces must be absolutely level ($\pm 0.1\text{mm}$ flatness fault), so that the feet of the vibrators have full area contact and to avoid warping of the housing when tightening the fastening screws. The surfaces should also be free of any paint residues and weld penetrations. Tensions in the housing can cause mechanical and/or electrical damage.



For safe fastening we recommend the use of Netter NBS screw connections consisting of screw, special lock washer and, if necessary, nut.

The vibrators can also be fastened with fastening screws of quality 8.8 (DIN 931 or 933). These must be locked with qualified locking devices and retightened at regular intervals (normally every month).



DANGER

In critical installation situations the unit must be secured with a safety rope.



WARNING

The tightening torques can be taken from the following table. Higher tightening torques may cause fracture of screws or tearing of threads. Inadequate screw connections may cause loosening of vibrators by vibration. This can cause damage to persons and material!



Recommended tightening torques for fastening screws

(screws as supplied, without additional lubrication):

Type of screw	M6	M8	M10	M12	M14	M16	M18	M20	M24
Property class 8.8 [Nm]	10	23	48	80	130	190	270	380	650
Stainless steel screws [Nm]	8	20	40	67	112	-	-	-	-

Use a torque wrench and tighten the screws in a crosswise pattern.

6.2 Electrical connection



**IMPOR-
TANT**

The electrical installation of the vibrators must be performed only by authorized, qualified personnel.
The qualified personnel must use only insulated tools, which are suitable for the application.

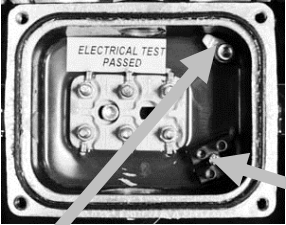
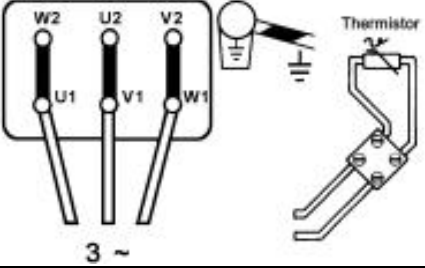
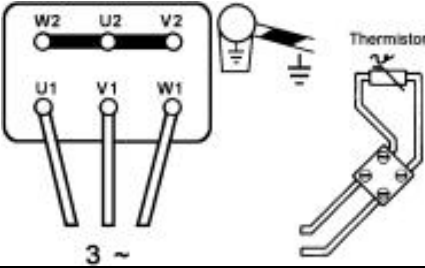
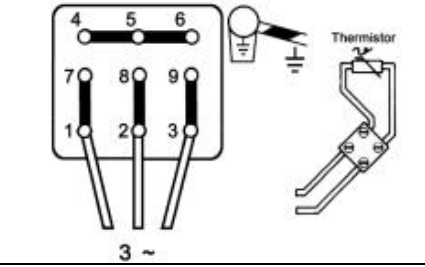
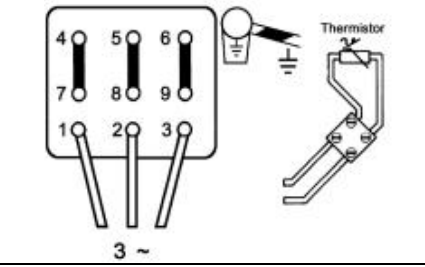
<p>In accordance with its connected voltage the circuitry specified in the terminal box must be connected as follows</p>  <p>Thermistor</p>	Terminal plan III*	
	<p>Series NEG / alternating current 3-phase Lower voltage</p> 	<p>Higher voltage</p> 
<p>The green-yellow conductor is the earth conductor and must only be used for connection to the earth terminal.</p>	Terminal plan IV	
	<p>Series NEG / alternating current 3-phase Lower voltage</p> 	<p>Higher voltage</p> 
<p>More terminal plans (e.g. for special voltages) on request.</p>		
<p>* The regulation for connection of the PTC-thermistor in areas with explosive dust (zones 21 and 22) does not apply to units which are not equipped with PTC-thermistor (standard fitting from housing size 170 upwards).</p>		



**IMPOR-
TANT**

The mains voltage and the mains frequency have to correspond to the nominal voltage and frequency indicated on the type plate. A voltage tolerance of $\pm 5\%$ or a frequency tolerance of $\pm 2\%$ are admissible.



The connection of the vibrators has to be made only by using the appropriate flexible cables.

The conductors in the feed cable for the connection of the vibrator to the mains supply must be temperature-resistant and have a sufficient large cross-section matched to the length of the cable used.

The max. surface temperature indicated on the type plate determines the degree of temperature resistance of the cable.



Unbalance type XLs

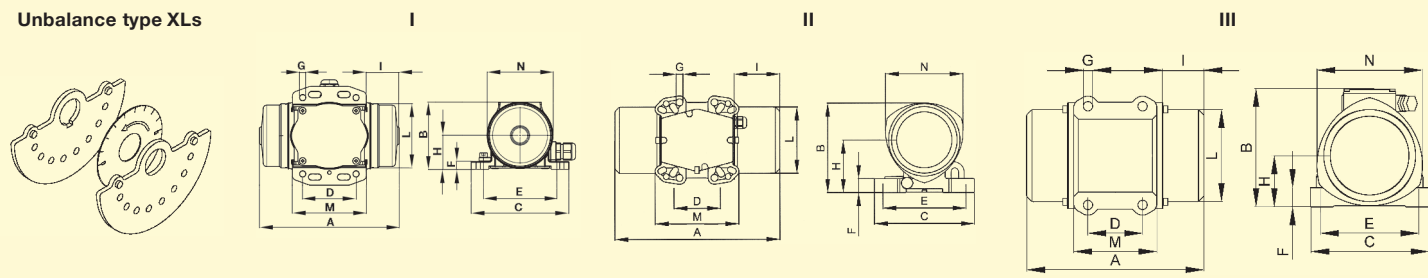

Type	Weight [kg]		Type of Housing	Dimensions [mm]													Unbalance [No. of Unbalance Discs]					
	NEG/NEA			NEG/NEA	NEG/NEA													NEG/NEA				
	50 Hz	60 Hz			A	B	C	Mounting Pattern*			D	E	n ₂	F	G	H	I	L	M	N	Type	50/60 Hz
NEA 504	1,00	1,00	I	111	67	90	25-40	75	4	9	5,5	34	24	63	59	65	XL	8				
NEG/NEA 5020	2,20	2,20	I	157	75	110	60	85	4	9	6,5	38	33	72	83	74	XL	8				
NEG/NEA 5050	2,45	2,45		25-40			92	9										6,5	38	39	18	
NEG/NEA 5060	4,9	4,9	II	197	121	125	60	100	4	20	8,5	71	33	92	86	105	XLs	4				
							62	95														
							65	85														
							70	106														
NEG/NEA 50120	5,9	5,8	II	207	143	165	62-74	106	4	25	13	86	44	100	156	123	XM	4				
							80	110														
							115	135														
NEG/NEA 50200	6,5	6,3	II	223	143	165	115	135	4	25	11	86	52	100	156	123	XM	4				
							135	115														
							124	110														
NEG/NEA 50300	10,2	10,0	II	247	173	165	65	140	4	25	13	103	50	124	156	146	XM	4				
							80	110														
							115	135														
							135	115														
							124	110														
							90	125														
NEG/NEA 50550	16,3	16,1	II	283	192	217	100	180	4	30	17	113	63	143	137	168	XM	4				
							105	140														
							13	13														
NEG/NEA 50770	22,1	21,6	III	308	212,5	226	100	180	4	35	17	93,5	63	167	162	193	XM	4				
NEG 50980	24,5	23,4	III	314	217	217	100	180	4	35	17	93,5	76	168	152	193	XM	4				
NEG 501140	25,0	24,0																				
NEG/NEA 2530	6,1	5,8	II	207	143	165	65	140	4	25	13	86	44	100	156	123	XM	4				
							62-74	106														
							80	110														
							115	135														
NEG/NEA 2570	7,3	6,9	II	243	143	165	115	135	4	25	11	86	62	100	156	123	XM	4				
							135	115														
							124	110														
							11	11														
NEG/NEA 25210	12,8	11,8	II	307	173	165	65	140	4	25	13	103	80	124	156	146	XS	4				
							80	110														
							115	135														
							135	115														
							124	110														
							90	125														
NEG/NEA 25420	20,7	19,7	II	355	192	217	100	180	4	30	17	113	99	143	137	168	XS	4				
							105	140														
NEG/NEA 25540	22,7	21,7	II	391	192	217	105	140	4	30	13	113	117	143	137	168	XS	4				
NEG/NEA 25700	29,4	28,4	III	392	212,5	226	100	180	4	35	17	93,5	105	167	162	193	XS	4				
NEG 25930	34,2	32,7	III	442	217	217	100	180	4	35	17	93,5	140	168	152	193	XS	4				
NEG 1630	12,0	10,1	II	247	173	165	65	140	4	25	13	103	50	124	156	146	XM	4				
							80	110														
							115	135														
							135	115														
NEG 1690	12,7	12,7	II	307	173	165	124	110	4	25	11	103	80	124	156	146	XS	4				
							90	125														
							11	11														
							13	13														
NEG 16190	20,5	20,5	II	355	192	217	100	180	4	30	17	113	99	143	137	168	XS	4				
NEG 16310	28,9	27,9	III	392	212,5	226	100	180	4	35	17	93,5	105	167	162	193	XS	4				
NEG 16410	34,1	33,6	III	442	217	217	100	180	4	35	17	93,5	140	168	152	193	XS	4				
NEG 16500	36,1	35,1																				
NEG 12100	20,5	20,5	II	355	192	217	100	180	4	30	17	113	99	143	137	168	XS	4				
							105	140														
NEG 12180	28,0	28,0	III	392	212,5	226	100	180	4	35	17	93,5	105	167	162	193	XS	4				
NEG 12230	34,6	34,6	III	442	217	217	100	180	4	35	17	93,5	140	168	152	193	XS	4				
NED 50100	5,0	II	208	146,5	162	65	140	4	25	13	88	45	100	157	117	XM	4					
						115/135	135/115															
						74/80	106/110															
NED 50200	6,0	II	257	146,5	162	65/115	140/135	4	25	13	88	53	100	140	117	XM	4					
						74/80	106/110															
NEG 50500	13,1	II	288	203	167	105	140	4	30	13	82,5	65	145	140	160	XM	4					
NEG 601110	20	III	308	215	205	120	170	4	45	17	94	63	168	160	182	XM	4					

*Variable mounting pattern see operating manual, **Recommended mounting pattern in bold type.



NetterVibration



Netter Electric External Vibrators Series NEG Single Phase

Unbalance type XLs

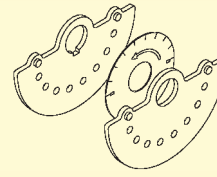

Unbalance type XS

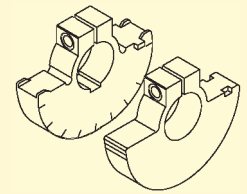

min ⁻¹	Type	Size	Housing Material	Unbalance [cmkg]		Centrifugal Force [N]		EE e II *	Power Input [kW]		Nominal Current [A]		Weight [kg]	
				50 Hz	60 Hz	50 Hz	60 Hz		50/60 Hz	50 Hz 400 V	60 Hz 480 V	50 Hz 400 V	60 Hz 480 V	50 Hz
3000 6000	NEG 501540	140	AL	30,6	20,4	15.103	14.499	T3, T4	1,4	1,45	2,3	2,0	34,3	32,8
	NEG 501800			35,8	25,6	17.669	18.195	T3	2,0	2,0	3,3	2,9	35,1	33,6
	NEG 502020	150	GGG	41,0	25,6	20.236	18.195	T3	2,2	2,2	3,5	3,0	49	47
	NEG 502270			46,0	30,6	22.704	21.748	T3	2,2	2,2	3,5	3,0	50	49
	NEG 503400			65,6	43,7	32.364	31.052	-	3,8	3,8	6,2	5,4	106	102
	NEG 503820	170	GGG	76,5	54,6	37.764	38.827	-	4,0	4,0	6,5	5,6	107	103
	NEG 506220			126,0	88,6	62.189	62.970	-	5,5	5,5	9,2	8,0	188	181
NEG 508830	190	GGG	179,0	123,8	88.347	87.988	-	10,0	9,3	18,0	13,0	215	210	
1500 1800	NEG 251410	140	AL	112	80,0	13.820	14.215	T3, T4	0,9	1,05	1,45	1,5	44,8	41,8
	NEG 251800			142,8	97,0	17.620	17.235		1,1	1,2	2,0	1,9	49,3	45,3
	NEG 252060	160	AL	163	112,4	20.113	19.971	-	1,35	1,45	2,5	2,3	54	52
	NEG 252370			192,4	134,8	23.740	23.951	T3, T4	1,6	1,7	3,2	3,0	75	69
	NEG 253050			247,0	171,6	30.477	30.490	-	1,9	2,0	3,8	3,5	82	79
	NEG 253720	170	GGG	301,6	206,7	37.214	36.726	T3, T4	2,2	2,5	3,9	3,9	127	122
	NEG 254310			349,2	234,7	43.088	41.702	-	2,5	2,8	4,8	4,65	125	120
	NEG 254900	180	GGG	396,8	272,8	48.961	48.472	T3	3,6	3,4	6,0	5,0	174	166
	NEG 256460	190	GGG	523,8	364,6	64.632	64.783	-	6,0	6,0	10,5	9,0	212	200
	NEG 258040	195	GGG	652,0	452,0	80.450	80.312	-	7,0	8,0	11,6	11,5	225	210
	NEG 258260	197	GGG	669,2	492,4	82.573	87.490	-	7,5	8,5	12,2	12,0	317	303
	NEG 2511210	200	GGG	908,8	633,2	112.137	112.508	-	10,0	10,5	17,5	15,5	433	411
	NEG 2513850			1.122,8	825,2	138.542	145.981	-	11,0	12,0	20,0	20,0	458	424
1000 1200	NEG 16810	140	AL	144,2	111,8	7.908	8.829	T3, T4	0,68	0,76	1,4	1,4	46	41
	NEG 161130			202,0	142,8	11.078	11.277		0,75	0,75	1,7	1,5	57	48
	NEG 161420			254,2	187,4	13.940	14.799		-	0,95	1,0	1,8	1,7	65
	NEG 161610	160	AL	292,8	192,4	16.057	15.194	T3, T4	1,1	1,3	2,2	2,2	80	76
	NEG 162110			385,4	263,6	21.135	20.816		-	1,5	1,77	3,0	2,8	95
	NEG 162550	170	GGG	464,2	323,0	25.457	25.507	T3	1,96	2,1	4,1	3,75	140	127
	NEG 163030			553,4	400,0	30.348	31.588	-	2,2	2,4	4,5	4,3	156	141
	NEG 163820	180	GGG	696,4	467,4	38.191	38.253	T3, T4	2,5	3,0	5,1	5,0	200	182
	NEG 164700			857,0	587,4	46.998	46.387	-	3,2	3,6	6,5	6,0	219	198
	NEG 165190	190	GGG	946,4	658,4	51.901	51.994	T3	3,8	4,0	7,0	6,5	247	225
	NEG 165580			1.008,8	706,2	54.560	55.768	-	3,8	3,9	7,0	7,1	240	245
	NEG 166270			1.142,8	795,0	62.671	62.781	-	4,3	5,0	8,2	8,1	279	251
	NEG 166670	197	GGG	1.216,6	795,8	66.718	62.844	-	5,0	5,9	10,0	9,8	285	257
	NEG 167890	195	GGG	1.439,4	993,4	78.937	78.448	-	7,0	7,5	9,6	13,0	320	282
	NEG 168500			1.550,4	1.077,0	85.024	85.050	-	7,5	8,2	14,0	12,9	326	289
	NEG 169510	197	GGG	1.734,6	1.132,8	95.125	89.457	-	7,6	8,0	13,5	12,4	381	340
	NEG 1612060	200	GGG	2.199,2	1.508,6	120.604	119.134	-	9,0	9,5	16,3	15,0	500	445
	NEG 1613890	205	GGG	2.532,4	1.740,0	138.877	137.407	-	10,6	11,3	19,0	18,0	643	605
	NEG 1617000			3.100,0	2.087,8	170.004	164.873	-	13,0	13,7	24,5	23,0	705	656
750 900	NEG 12460	140	AL	144,4	142,2	4.454	6.317	T3	0,4	0,45	1,2	1,2	46	46
	NEG 12640			202,0	195,6	6.231	8.689	T3, T4		0,5	1,4	1,3	57	57
	NEG 12900	160	AL	292,8	292,8	9.032	13.006	T3	0,95	1,1	2,2	2,2	80	80
	NEG 121430	170	GGG	464,2	464,2	14.319	20.620	T3	1,5	1,79	4,1	4,2	133	133
	NEG 122150	180	GGG	696,4	696,4	21.482	30.934	T3	2,0	2,3	5,4	5,2	201	201
	NEG 122640			857,0	857,0	26.436	38.068	-	2,5	3,0	6,0	6,0	217	217
	NEG 122920	190	GGG	964,4	964,4	29.194	42.839	T3	2,8	3,35	6,5	6,5	242	242
	NEG 123530			1.142,8	1.142,8	35.253	50.764	T3	4,0	4,3	8,2	7,85	267	267
	NEG 124440	195	GGG	1.439,4	1.439,4	44.402	63.939	-	4,9	5,8	9,9	9,5	320	320
	NEG 127640	197	GGG	2.478,0	2.194,6	76.440	97.485	-	6,8	7,5	13,2	12,0	438	419
	NEG 128520	200	GGG	2.763,2	2.481,4	85.238	110.225	-	7,6	8,3	14,0	13,5	540	520
	NEG 1211070	205	GGG	3.589,2	3.100,0	110.718	137.703	-	9,2	9,6	21,0	19,5	702	680
	NEG 1213160			4.267,4	3.812,8	131.639	169.366	-	10,4	11,2	22,0	20,0	755	711
	NEG 1217670	210	GGG	5.726,6	4.901,6	176.651	217.731	-	12,5	16,2	26,5	28,0	1.015	981

*Technical data available upon request

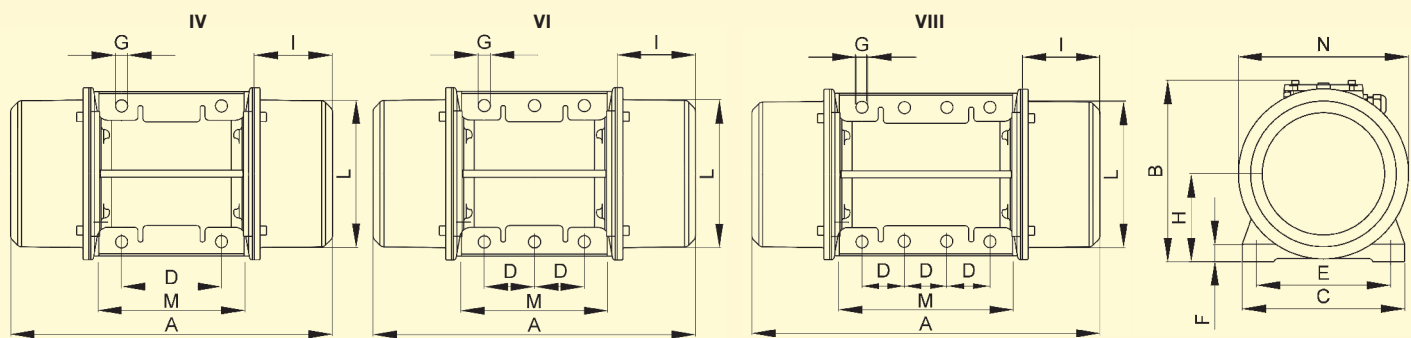

Type	Type of Housing NEG	Dimensions [mm]													Unbalance [No. of Unbalance Discs]	
		A 50/60 Hz	B	C	D	E	n ₂ Befestigungsmaße	F	G	H	I 50/60 Hz	L	M	N	Type	50/60 Hz
NEG 501540	IV	438	257	230	140	190	4	25	17	124,5	103	201	224	241	XLs	12/8
NEG 501800		14/10														
NEG 502020	IV	463	235	230	140	190	4	22	17	104	104	188	248	224	XLs	16/10
NEG 502270																18/12
NEG 503400	IV	590	335	310	155	255	4	30	23,5	160	140	274	302	310	XLs	12/8
NEG 503820																14/10
NEG 506220	IV	670	380	390	200	320	4	32	28	189	155	340	360	384	XS	4
NEG 508830	IV	629	395	392	200	320	4	100	28	192	134,5	358	270	375	XS	4
NEG 251410	IV	438	257	230	140	190	4	25	17	124,5	103	201	224	241	XS	4
NEG 251800		490														
NEG 252060		560														
NEG 252370		523														
NEG 253050	IV	600	283	275	155	225	4	28	22	140	130	231	255	271	XS	4
NEG 253720		670/588														
NEG 254310	IV	588	335	310	155	255	4	30	23,5	160	139	274	302	310	XS	4
NEG 254900	IV	640	369	340	180	280	4	30	26	173	155	301	322	336	XS	4
NEG 256460	IV	670	380	390	200	320	4	32	28	189	155	340	360	384	XS	4
NEG 258040	IV	624	402	392	200	320	4	35	28	199,5	132	358	352	402	XS	4
NEG 258260	VI	862	434,5	460	125	380	6	35	38	215	230	379	392	439	XS	4
NEG 2511210	VI	990	454	530	140	440	6	38	44	230	240	423	510	448	XS	4
NEG 2513850		490/438														
NEG 16810	IV	560	257	230	140	190	4	25	17	124,5	164	201	224	241	XS	4
NEG 161130		600/523														
NEG 161420		655/600														
NEG 161610	IV	670/610	283	275	155	225	4	28	22	140	168,5/130	231	255	271	XS	4
NEG 162110		180/150														
NEG 162550	IV	710	335	310	155	255	4	30	23,5	160	200	274	302	310	XS	4
NEG 163030		206														
NEG 163820	IV	742	369	340	180	280	4	30	26	173	236	301	322	336	XS	4
NEG 164700		206														
NEG 165190	IV	772	380	390	200	320	4	32	28	189	206	340	360	384	XS	4
NEG 165580		836														
NEG 166270		850														
NEG 166670	VI	750	434,5	460	125	380	6	35	39	215	174	379	392	439	XS	4
NEG 167890	IV	854	402	392	200	320	4	35	28	199,5	247	358	352	402	XS	4
NEG 168500		862														
NEG 169510	VI	862	434,5	460	125	380	6	35	39	215	230	379	392	439	XS	4
NEG 1612060	VI	990	454	530	140	440	6	38	44	230	240	423	510	448	XS	4
NEG 1613890	VIII	960	526	570	140	480	8	41	45	268	200	488	560	516	XS	4
NEG 1617000		1.040														
NEG 12460	IV	490	257	230	140	190	4	25	17	124,5	129	201	224	241	XS	4
NEG 12640		560														
NEG 12900	IV	600	283	275	155	225	4	28	22	140	168,5	231	255	271	XS	4
NEG 121430	IV	670	335	310	155	255	4	30	23,5	160	180	274	302	310	XS	4
NEG 122150	IV	742	369	340	180	280	4	30	26	173	206	301	322	336	XS	4
NEG 122640		802														
NEG 122920	IV	772	380	390	200	320	4	32	28	189	206	340	360	384	XS	4
NEG 123530		850														
NEG 124440	IV	854	402	392	200	320	4	35	28	199,5	247	358	352	402	XS	4
NEG 127640	VI	1.002	434,5	460	125	380	6	35	39	215	300	379	392	439	XS	4
NEG 128520	VI	1.070	454	530	140	440	6	38	44	230	280	423	510	448	XS	4
NEG 1211070	VIII	1.040	526	570	140	480	8	41	45	268	240	488	560	516	XS	4
NEG 1213160		1.120														
NEG 1217670	VIII	1.150	607	610	140	520	8	38	45	297	280	542	510	582	XS	4



NetterVibration

Unbalance type XL Unbalance type XM Unbalance type XS



Netter Electric External Vibrators
 Series NEG 3-Phase
 Series NEA Single Phase
 Series NED Direct Current

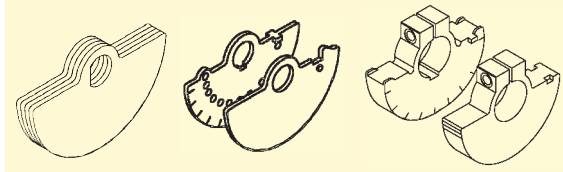

min ⁻¹	Type	Housing- Size Material		Unbalance [cmkg]		Centrifugal Force [N]		EEx e II **	Power Input [kW]				Nominal Current [A]				
		NEG/NEA		NEG/NEA		NEG/NEA			NEG E	NEG		NEA		NEG		NEA	
				50 Hz	60 Hz	50 Hz	60 Hz			50/60 Hz	50 Hz 400 V	60 Hz 480 V	50 Hz 230 V	60 Hz 115 V	50 Hz 400 V	60 Hz 480 V	50 Hz 230 V
3000 3600	NEA 504*	50	Al	0,08	0,08	40	57	-	-	-	0,024	0,024	-	-	0,13	0,30	
	NEG/NEA 5020*	60	Al	0,39	0,39	192	277	-	0,035	0,035	0,035	0,035	0,15	0,15	0,17	0,42	
	NEG/NEA 5050*			0,91	0,91	450	647	-	0,045	0,045	0,045	0,045	0,16	0,16	0,20	0,46	
	NEG/NEA 5060	100	Al	1,272	1,272	627	904	-	0,12	0,12	0,11	0,11	0,27	0,23	0,56	1,52	
	NEG/NEA 50120	101	Al	2,4	2,4	1.185	1.708	-	0,18	0,18	0,165	0,165	0,35	0,30	0,75	1,52	
	NEG/NEA 50200			4,2	3,0	2.073	2.133	-	-	-	-	-	-	-	-	-	
	NEG/NEA 50300	110	Al	6,02	4,08	2.972	2.900	T3,T4	0,26	0,27	0,28	0,28	0,60	0,50	1,25	2,40	
	NEG/NEA 50550	120	Al	9,99	6,48	4.930	4.606	T3,T4	0,45	0,50	0,5	0,5	0,80	0,75	2,30	4,50	
	NEG/NEA 50770	130	Al	15,59	10,40	7.695	7.392	T3,T4	0,65	0,685	0,7	0,75	1,10	1,00	3,25	7,00	
NEG 50980 NEG 501140	133	Al	19,8	13,2	9.772	9.382	T3,T4	1	1,2	-	-	1,75	1,75	-	-		
			23,0	16,5	11.352	11.727											
1500 1800	NEG/NEA 2530	101	Al	2,4	2,4	296	426	-	0,085	0,095	0,09	-	0,21	0,20	0,43	-	
	NEG/NEA 2570			6,2	4,2	766	747										
	NEG/NEA 25210	110	Al	16,84	11,76	2.078	2.090	T4	0,17	0,17	0,21	-	0,41	0,40	1,00	-	
	NEG/NEA 25420 NEG/NEA 25540	120	Al	32,64	22,66	4.028	4.027	T3,T4	0,30	0,35	0,24	-	0,60	0,60	1,20	-	
				43,80	32,64	5.405	5.800										
	NEG/NEA 25700	130	Al	57,18	41,89	7.056	7.444	T3,T4	0,525	0,665	0,45	-	0,92	0,98	2,50	-	
NEG 25930	133	Al	75,0	52,0	9.254	9.239	T4	0,55	0,68	-	-	0,95	0,95	-	-		
1000 1200	NEG 1630	110	Al	6,02	6,02	331	476	-	0,12	0,135	-	-	0,30	0,30	-	-	
	NEG 1690			16,84	16,84	924	1.330										
	NEG 16190	120	Al	32,64	32,64	1.790	2.578	T4	0,185	0,205	-	-	0,50	0,50	-	-	
	NEG 16310	130	Al	57,18	41,89	3.136	3.309	T4	0,35	0,38	-	-	0,72	0,68	-	-	
	NEG 16410 NEG 16500	133	Al	75,0	52,0	4.113	4.106	T4	0,35	0,38	-	-	0,75	0,67	-	-	
				90,7	66,5	4.974	5.251										-
750 900	NEG 12100	120	Al	32,64	32,64	1.007	1.450	T3	0,23	0,25	-	-	0,85	0,76	-	-	
	NEG 12180	130	Al	56,8	56,8	1.752	2.523	T3	0,35	0,38	-	-	1,10	1,05	-	-	
	NEG 12230	133	Al	75,0	75,0	2.314	3.332	T4	0,28	0,30	-	-	0,60	0,68	-	-	
3000	NED 50100	102	Al	2,39		1.180		-	0,10 (12 V =)		0,10 (24 V =)		8 (12 V =)		4 (24 V =)		
	NED 50200	103	Al	4,21		2.080		-	0,19 (12 V =)		0,19 (24 V =)		16 (12 V =)		8 (24 V =)		
	NED 50500	122	Al	9,98		4.930		-	0,27		0,27		22,5		11,3		
3600	NED 601110	133	Al	15,6		11.087		-	0,53 (24 V =)				22 (24 V =)				

*Protection IP 65, **Technical data available upon request

When selecting the connecting cables, please consider the mechanical demands on the cables due to vibration.



IMPORTANT

The recommended cable types for power supply operation with 400 V in non-explosive atmosphere: rubber hose line H07 RN-F or oilflex cable 110 CY. In case of other voltages or other environmental conditions the cables have to be adapted and designed accordingly.

Cable and protective conductor have to be properly connected. The terminal plans can be found in the terminal box.



DANGER

ATTENTION:

The earthing screw labelled with the symbol \equiv is located inside the terminal box. This screw, which serves as **earthing connection** for the vibrator, must only be used to connect the protective conductor (green-yellow) of the power supply cable.



EXPLOSION HAZARD

In zones 21 and 22 an additional external earthing is to be made via the earthing connection of the housing base.

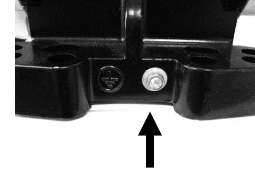

EXPLOSION HAZARD

The terminal box cover must not be opened in a potentially explosive area or with voltage applied.

If the terminal box cover or unbalance covers are open, check the condition and correct positioning of the seals. Damaged seals must be replaced immediately.

WARNUNG ! WARNING

Nicht öffnen in explosionsfähiger Atmosphäre.

Do not open in an explosive atmosphere

Cable temperature near the cable glands: 120°C



DANGER

The electric lines have to be laid with care. It has to be avoided that the cables can be chafed through by vibrating parts.

The condition of the electric lines incl. plugs has to be checked at regular intervals (normally every six months). Defects which are discovered have to be eliminated immediately.

Protect the cable against high temperatures, lubricants and sharp edges



IMPORTANT

The ends of the leads must be fitted with isolated cable clips, to prevent the strands from splaying.

The maximum cable clip sizes are shown in the following list:

- Set screw M4 max. AWG 18
- Set screw M5 max. AWG 16
- Set screw M6 max. AWG 12
- Set screw M8 max. AWG 12





DANGER

Tighten junction plate nuts using the prescribed torque. Be careful not to forget the safety washer between the ring and the nut and to reinsert the vibration-damping insert.

- M 4 ⇒ 1.2 Nm
- M 5 ⇒ 2.0 Nm
- M 6 ⇒ 3.0 Nm
- M 8 ⇒ 6.5 Nm
- M 10 ⇒ 13.5 Nm

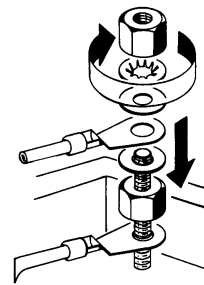

IMPOR-
TANT

Each vibrator must be connected to a suitable overload protection. For dual operation, the motor protection switches must be interlocked to ensure that in case one motor breaks down, the current supply is stopped from both motors simultaneously. This is to prevent uncontrolled vibrations, which could cause damage to the equipment



EXPLO-
SION
HAZARD

In zones 21 and 22 the motor protection switches have to be approved for applications in potentially explosive areas.



EXPLO-
SIONS-
GEFAHR

Thermic overload protection:

Standard equipment with PTC-thermistor 130°C from housing size 170 upwards.
For smaller units available as first equipment on request.

If the vibrator is operated in environments containing explosive dust (zone 21 and 22), it is mandatory to connect the PTC-thermistor. This regulation does not apply if the unit is not equipped with a PTC-thermistor.

7 Start-up



**IMPOR-
TANT**

During start-up of the vibrators the rules and regulations of local associations for electrical engineering (e.g. VDE) and the applicable accident prevention rules must be observed.

The vibrators must always be switched on and off at a main switch.

If the electric external vibrators are operated with a frequency converter, compliance with the EMC directive must be ensured.

If the rotary speed is regulated by means of a frequency converter, pay attention to the maximum frequency indicated on the type plate.



WARNING

The vibrator must not be operated without the cover for the unbalances in place! The rotating unbalances cause a risk of injury!



**EXPLO-
SION
HAZARD**

In zones 21 and 22 the frequency converter may regulate the frequency between 20 Hz and 50 Hz or 20 Hz and 60 Hz (please check max. frequency on type plate) at a constant torque load (linear Volt-Hertz-curve).

Explosion-protected vibrators must only be used in atmospheres which will not damage the material of the device.

The terminal box cover must not be opened in a potentially explosive area or when voltage is applied.

The complementary regulations and instructions for hazardous areas must be complied with.



DANGER

During initial start-up the current consumption must be measured individually in all three phases and must comply with the data on the type plate.



WARNING

The vibrators have to be adapted to your application by adjusting the unbalances. You can directly influence vibration amplitude, centrifugal force and current consumption, see chapter 8 „Adjustment of unbalances“.

Retightening:

Screw connections must be checked and, if necessary, retightened after 1 hour of operation (after initial start-up) and then at regular intervals (as a rule, once per month).

8 Adjustment of Unbalances



IMPORTANT

All vibrators of the series NEA, NED and NEG offer the possibility of adjusting the unbalances.

Unless otherwise specified by you, the units will be shipped with the default setting (100%).

By adjusting the unbalances you can directly influence the vibration amplitude, centrifugal force and current consumption.



WARNING

On all units the unbalances must only be adjusted symmetrically mirrored!

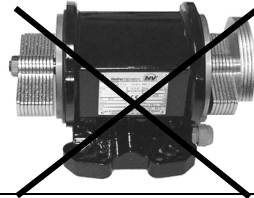

The tables below show the type of unbalance and the number of unbalances per vibrator at the default setting of 100%.

Type	Unbalance		
	Type	Number	
		12 V	24 V
NED 50100	XM	4	4
NED 50200	XM	4	4
NED 50500	XM	4	4
NED 601110	XM	4	4

Type	Unbalance		
	Type	Number	
		50 Hz	60 Hz
NEA 504	XL	8	8
NEA 5020	XL	8	8
NEA 5050	XL	18	18

NEA 5060	XLs	4	4
----------	-----	---	---

NEA 50120	XM	4	4
NEA 50200	XM	4	4
NEA 50300	XM	4	4
NEA 50550	XM	4	4
NEA 50770	XM	4	4
NEA 2530	XM	4	4
NEA 2570	XM	4	4
NEA 25210	XS	4	4
NEA 25420	XS	4	4
NEA 25540	XS	4	4
NEA 25700	XS	4	4

Type	Unbalance		
	Type	Number	
		50 Hz	60 Hz
NEG 5020	XL	8	8
NEG 5050	XL	18	18

NEG 5060	XLs	4	4
----------	-----	---	---

NEG 50120	XM	4	4
NEG 50200	XM	4	4
NEG 50300	XM	4	4
NEG 50550	XM	4	4
NEG 50770	XM	4	4
NEG 50980	XM	4	4
NEG 501140	XM	4	4

NEG 501540	XLs	12	8
NEG 501800	XLs	14	10
NEG 502020	XLs	16	10
NEG 502270	XLs	18	12
NEG 503400	XLs	12	8
NEG 503820	XLs	14	10

NEG 506220	XS	4	4
NEG 508830	XS	4	4

Type	Unbalance		
	Type	Number	
		50 Hz	60 Hz
NEG 2530	XM	4	4
NEG 2570	XM	4	4

NEG 25210	XS	4	4
NEG 25420	XS	4	4
NEG 25540	XS	4	4
NEG 25700	XS	4	4
NEG 25930	XS	4	4
NEG 251410	XS	4	4
NEG 251800	XS	4	4
NEG 252060	XS	4	4
NEG 252370	XS	4	4
NEG 253050	XS	4	4
NEG 253720	XS	4	4
NEG 254310	XS	4	4
NEG 254900	XS	4	4
NEG 256460	XS	4	4
NEG 258040	XS	4	4
NEG 258260	XS	4	4
NEG 2511210	XS	4	4
NEG 2513850	XS	4	4

NEG 1630	XM	4	4
----------	----	---	---

NEG 1690	XS	4	4
NEG 16190	XS	4	4
NEG 16310	XS	4	4
NEG 16410	XS	4	4
NEG 16500	XS	4	4
NEG 16810	XS	4	4
NEG 161130	XS	4	4
NEG 161420	XS	4	4
NEG 161610	XS	4	4
NEG 162110	XS	4	4
NEG 162550	XS	4	4
NEG 163030	XS	4	4
NEG 163820	XS	4	4
NEG 164700	XS	4	4
NEG 165190	XS	4	4
NEG 166270	XS	4	4
NEG 166670	XS	4	4
NEG 167890	XS	4	4
NEG 168500	XS	4	4
NEG 169510	XS	4	4
NEG 1612060	XS	4	4
NEG 1613890	XS	4	4
NEG 1617000	XS	4	4

Type	Unbalance		
	Type	Number	
		50 Hz	60 Hz
NEG 12100	XS	4	4
NEG 12180	XS	4	4
NEG 12230	XS	4	4
NEG 12460	XS	4	4
NEG 12640	XS	4	4
NEG 12900	XS	4	4
NEG 121430	XS	4	4
NEG 122150	XS	4	4
NEG 122640	XS	4	4
NEG 122920	XS	4	4
NEG 123530	XS	4	4
NEG 124440	XS	4	4
NEG 127640	XS	4	4
NEG 128520	XS	4	4
NEG 1211070	XS	4	4
NEG 1213160	XS	4	4
NEG 1217670	XS	4	4

Procedure:

- Switch off vibrator, secure it against unintentional switching on and make sure that no voltage is applied.
- Loosen both covers for the unbalances.
- Slacken the locking nuts or locking screws.
- Adjust the discs or cast iron unbalances as required.
- Tighten the locking nuts or locking screws.
- Reinstall the covers for the unbalances.

Unbalance discs type XLs

The unbalance setting of the unbalance discs of type XLs is made via the scale disc.

The centrifugal force is adjusted by turning the outer unbalance discs and adjusting them to the pitch lines on the scale disc



Discs	4, 8, 12, 16	10	14	18	NEG 5060 4 Scheiben
Setting	Centrif. force in %	Centrif. force in %	Centrif. force in %	Centrif. force in %	Centrif. force in %
0°	100	100	100	100	100
20°	99	99	99	99	97
40°	94	94	94	94	88
60°	87	87	87	87	75
80°	76	78	77	77	59
100°	64	66	65	65	41
120°	50	53	52	51	25
140°	34	29	37	36	12
160°	17	26	22	21	3
180°	0	20	14	11	0

Unbalance discs type XM

The unbalance setting of the unbalance discs type XM is made via the scale of the fixed unbalance disc. The centrifugal force is set by turning the outer unbalance disc and by adjusting to the scale division lines. The adjustment can be made in 10%-steps.



Recommended average tightening torques for nuts

Nut type	M13 × 1	M15 × 1	M20 × 1	M25 × 1,5	M30 × 1,5	M45 × 1,5
Tightening torque [Nm]	30	50	100	170	340	500

The unbalance setting of the unbalance discs type XS is made via the scale of the fixed disc.

The centrifugal force is infinitely adjusted by turning the outer unbalance discs and adjusting them to the scale lines on the scale disc. After adjusting the unbalances, nuts or screws must be retightened with the specified tightening torque.

With unbalance discs of type XS the centrifugal force can be adjusted according to the following table:

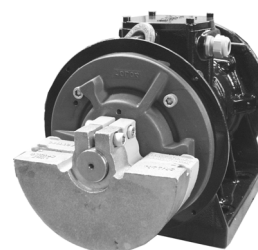

Setting	Centrif. force in %
0°	100
15°	98,5
30°	97
45°	92
60°	87
75°	78,5
90°	70

Setting	Centrif. force in %
105°	60
120°	50
135°	37,5
150°	25
165°	12,5
180°	0

Screw type	M6	M8	M10	M12	M14	M16	M18	M20	M24
8.8 Tightening torque [Nm]	10	23	48	80	130	190	270	380	650
12.9 Tightening torque [Nm]	-	39	79	135	218	314	-	628	-

For screw types M8 to M14 strength class 12.9 is used by default.

9 Trouble shooting



IMPORTANT

Faults on vibrators must only be repaired by authorized, qualified personnel. The qualified personnel must use only insulated tools, which are suitable for the application.

Fault	Possible cause	Trouble shooting	Remedy
Vibrator does not start or runs with too low speed	Phase interruption	Check fuse and connecting cable	Replace fuse or connecting cable
	Mains voltage too low	Check mains voltage and cable cross-section	Correct mains voltage, replace cable
Vibrator speed drops under load	Wiring fault	Check with terminal plan	
	Insufficient contact on a connecting terminal	Check connection in terminal box	Tighten terminal nuts
	Phase interruption	Check fuse and connecting cable	Replace fuse or connecting cable
	Incorrectly dimensioned connecting cable	Check cable-cross section	Replace the cable
	Overload	Check setting of unbalances	Reduce the unbalance
	Mains voltage too low	Check mains voltage and cable cross-section	Correct mains voltage, replace cable
One phase without current	Phase interruption	Check the connecting cable	Replace the cable
Excessive heating of stator winding	Wiring fault	Check with terminal plan	
	Overload		
	Mains voltage too low	Check mains voltage and cable cross-section	Correct mains voltage, replace cable
Vibrator humming	Phase interruption	Check fuse, mains voltage and connecting cable	Correct mains voltage, replace fuse or cable
	Turn-to-turn fault in the stator winding	Replace the vibrator	
Circuit breaker fails when switched on	Phase interruption	Check fuse and connecting cable	Replace fuse or cable
	Overload	Check setting of unbalances	Reduce the unbalance
	Short circuit in winding	Replace the vibrator	
High current consumption	Natural resonance range of vibration system	Check the current consumption	Stiffen the device
	Impact	Check the current consumption	Reduce the power of the vibrator
		Fastening loose	Tighten the screws
Bearings overheating	Too much grease in bearings	Fill in correct quantity of grease Klueber Staburags NBU 8 EP.	
	No grease in bearing	Fill in correct quantity of grease Klueber Staburags NBU 8 EP.	
	Foreign body in bearing	Clean bearing, replace if necessary.	

10 Service / Maintenance

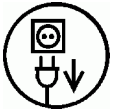

**DISCON-
NECT
POWER
SUPPLY**

When working on the vibrator it must be isolated from the mains supply. To do so please proceed as follows:

1. Switch off the vibrator
2. Secure it against switching on
3. Make sure it is deenergized

The following maintenance work has to be carried out at regular intervals by authorized and specialized staff with good knowledge of the standards EN 61241-17 (zones 21 and 22):

- a) Checking of the screwed connections
- b) Checking of the ball and roller bearings
- c) Relubricating of roller bearings
- d) Checking of operating hours (service life of bearings)
- e) Checking of cable supply line
- f) Replacement of o-rings and plastic seals every two years



WARNING

Other maintenance and repair work are to be carried out by *Netter*Vibration exclusively.

Authorized and specialized staff is allowed to perform the following work on the vibrators:

The adjustment of the unbalance discs incl. removal of the unbalance covers.

The electric connection incl. removal of the terminal block cover.

Please observe the safety instructions in chapter 2 when service on the unit is done.



WARNING

Retightening:

Screw connections must be checked and, if necessary, retightened after 1 hour of operation (after initial start-up) and then at regular intervals (normally every month). Pay attention to the specified torque (see chapter 6.1).

Lubrication

Vibrators up to casing size 120 are equipped with ball bearings. These are lifetime lubricated (permanent lubrication).

From housing size 130 the units are fitted with roller bearings, these are lubricated with grease of type KLUEBER Staburags NBU 8 EP. This grease has the advantage that the bearings are lubricated for a period of at least 5000 operating hours (up to 3000 rpm). After this time the grease in the bearings must be completely renewed.

Vibrators with speeds exceeding 3000 rpm must be lubricated regularly in intervals of approx. 1000 operating hours.

Under severe operating conditions the lubrication intervals must be considerably shorter.

Service life of ball respectively roller bearings

If the vibrator is used in potentially explosive dust atmosphere, the operator has to control the condition of the bearings and the operating time of the complete unit. Vibrators with defective bearings or with bearings which have reached the end of service life, have to be sent to **Netter**Vibration for exchange immediately.



DANGER

The condition of the ball and roller bearings must be regularly checked.
The replacement of damaged bearings or bearings which have reached the end of their service life must be made by **NetterVibration**.

Grease quantity for lubrication and when replacing bearings and bearing life

Type	Grease quantity [g]	Bearing lifetime 50 Hz [h]	Bearing lifetime 60 Hz [h]
NED 50100	Perm. lubrication	20.421	-
NED 50200	Perm. lubrication	3.851	-
NED 50500	Perm. lubrication	2.161	-
NED 601110	Perm. lubrication	938	-

NEA 504	Perm. lubrication	> 100.000	> 100.000
NEA 5020	Perm. lubrication	92.118	22.745
NEA 5050	Perm. lubrication	8.087	2.236
NEA 5060	Perm. lubrication	> 100.000	5.044
NEA 50120	Perm. lubrication	18.075	18.075
NEA 50200	Perm. lubrication	3.363	2.572
NEA 50300	Perm. lubrication	4.003	3.588
NEA 50550	Perm. lubrication	4.148	4.219
NEA 50770	Perm. lubrication	7.509	6.257

NEA 2530	Perm. lubrication	> 100.000	> 100.000
NEA 2570	Perm. lubrication	> 100.000	> 100.000
NEA 25210	Perm. lubrication	23.406	19.200
NEA 25420	Perm. lubrication	15.135	12.635
NEA 25540	Perm. lubrication	6.266	4.224
NEA 25700	Perm. lubrication	19.477	16.231

NEG 5020	Perm. lubrication	92.118	22.745
NEG 5050	Perm. lubrication	8.087	2.236
NEG 5060	Perm. lubrication	> 100.000	5.044
NEG 50120	Perm. lubrication	18.075	18.075
NEG 50200	Perm. lubrication	3.363	2.572
NEG 50300	Perm. lubrication	4.003	3.588
NEG 50550	Perm. lubrication	4.148	4.219
NEG 50770	Perm. lubrication	7.509	6.257
NEG 50980	9	5.062	4.833
NEG 501140	9	3.029	2.298
NEG 501540	16	4.038	3.856
NEG 501800	16	2.416	1.833
NEG 502020	30	7.070	8.372
NEG 502270	30	4.775	4.558
NEG 503400	40	8.672	10.267
NEG 503820	40	5.856	5.591
NEG 506220	120	5.743	4.636
NEG 508830	150	9.029	2.790

NEG 2530	Perm. lubrication	> 100.000	> 100.000
NEG 2570	Perm. lubrication	> 100.000	> 100.000
NEG 25210	Perm. lubrication	23.406	19.200
NEG 25420	Perm. lubrication	15.135	12.635
NEG 25540	Perm. lubrication	6.266	4.224
NEG 25700	Perm. lubrication	19.477	16.231
NEG 25930	9	12.103	10.190
NEG 251410	16	10.870	8.330
NEG 251800	30	22.231	20.009
NEG 252060	30	14.300	12.300
NEG 252370	35	16.159	13.032
NEG 253050	35	7.100	5.900

Type	Grease quantity [g]	Bearing lifetime 50 Hz [h]	Bearing lifetime 60 Hz [h]
NEG 253720	40	12.228	11.086
NEG 254310	40	8.200	7.300
NEG 254900	80	9.930	8.648
NEG 256460	120	10.478	8.451
NEG 258040	150	9.029	7.575
NEG 258260	180	11.460	7.881
NEG 2511210	260	10.576	8.718
NEG 2513850	300	9.000	6.200

NEG 1630	Perm. lubrication	> 100.000	> 100.000
NEG 1690	Perm. lubrication	> 100.000	> 100.000
NEG 16190	Perm. lubrication	> 100.000	72.171
NEG 16310	Perm. lubrication	> 100.000	> 100.000
NEG 16410	9	> 100.000	> 100.000
NEG 16500	9	> 100.000	39.516
NEG 16810	Perm. lubrication	> 100.000	60.144
NEG 161130	Perm. lubrication	54.020	42.632
NEG 161420	Perm. lubrication	25.100	20.000
NEG 161610	30	29.165	29.270
NEG 162110	30	11.800	10.400
NEG 162550	32	17.701	12.292
NEG 163030	32	41.500	30.500
NEG 163820	60	13.073	10.842
NEG 164700	80	18.364	15.425
NEG 165190	100	19.206	15.157
NEG 166270	120	15.786	13.144
NEG 166670	120	13.767	14.000
NEG 167890	150	14.431	12.276
NEG 168500	150	11.266	9.379
NEG 169510	180	10.728	10.972
NEG 1612060	260	11.000	11.800
NEG 1613890	300	13.327	11.510
NEG 1617000	360	11.273	10.404

NEG 12100	Perm. lubrication	> 100.000	> 100.000
NEG 12180	Perm. lubrication	> 100.000	> 100.000
NEG 12230	9	> 100.000	> 100.000
NEG 12460	Perm. lubrication	> 100.000	> 100.000
NEG 12640	Perm. lubrication	> 100.000	> 100.000
NEG 12900	30	> 100.000	65.414
NEG 121430	32	> 100.000	39.702
NEG 122150	60	> 100.000	29.320
NEG 122640	80	> 100.000	41.200
NEG 122920	100	> 100.000	43.076
NEG 123530	120	> 100.000	35.405
NEG 124440	150	> 100.000	32.368
NEG 127640	180	29.652	10.982
NEG 128520	260	52.762	18.667
NEG 1211070	300	37.822	15.233
NEG 1213160	360	35.257	12.684
NEG 1217670	400	22.520	9.347

Recommended tightening torques for screws (item 12 and item 22)

Type of screw	M6	M8	M10	M12	M14	M16	M18	M20	M24
8.8 Tightening torque [Nm]	10	23	48	80	130	190	270	380	650
12.9 Tightening torque [Nm]	-	39	79	135	218	314	-	628	-

Recommended tightening torques for nuts (item 25)

Nuts	M13×1	M15×1	M20×1	M25×1,5	M30×2	M45×1,5
Nm	30	50	100	170	340	500

Procedure to lubricate and replace bearings:

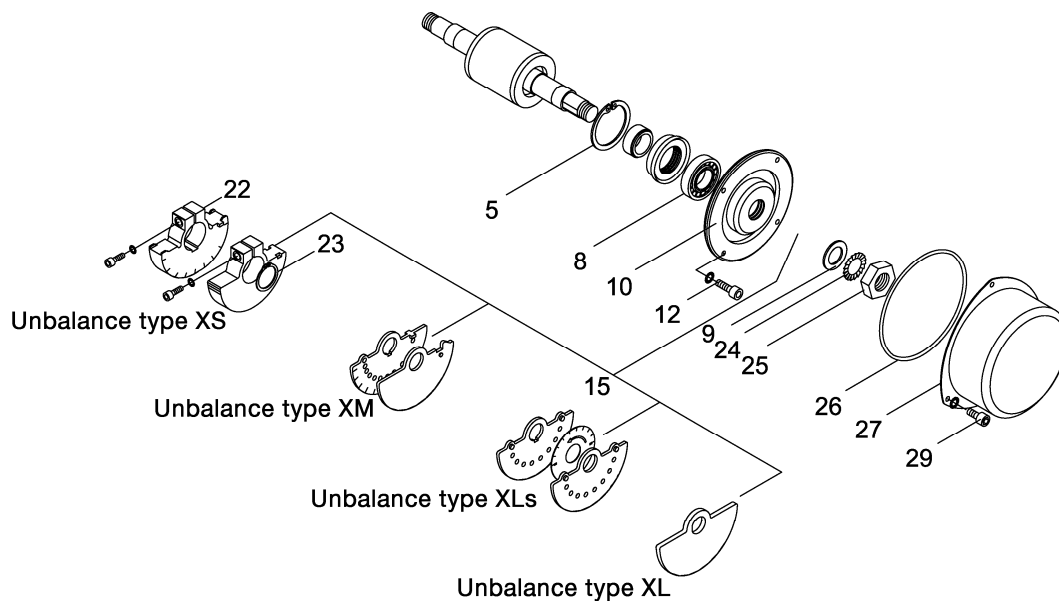

1. Switch off the vibrator, secure it reliably against switching on and make sure that it is dead.
2. Unscrew socket head cap screws (29) and remove covers (27) from the unbalances.
3. Disassembling the unbalances.

- Unbalances type XL, type XLs and type XM (15)

Screw a long screw with identical thread into a tapped bore for the fastening screws (29) of the cover for the unbalance. Place a chisel between unbalance discs and this screw. Loosen locking nut (25) (Fig. 1). The unbalances can be pulled off after unscrewing locking nut (25).

- Unbalances of type XS (15) (Fig. 2)

The unbalances can be pulled off after removing the circlip (23) and loosening the clamping screws (22).

4. Removing bearings (8):

- Up to housing size 120 remove circlip (5).
- From housing size 130 unscrew socket head cap screws (12) and disassemble flange (10). Remove circlip (5) from flange (10).

5. Replace both bearings (8) or clean off all old grease (e.g. with gasoline) and fill evenly with the specified quantity (table) of new grease (Klueber Staburags NBU 8 EP).

6. Assembly is performed in reverse order.

Tighten locking nuts (25) and socket head cap screws (12, 22) with the specified tightening torque.



Bild 1



Bild 2

11 Spare Parts

When ordering spare parts you should always provide the following details:

1. Type of unit
2. Description and position of the spare part
3. Required quantity

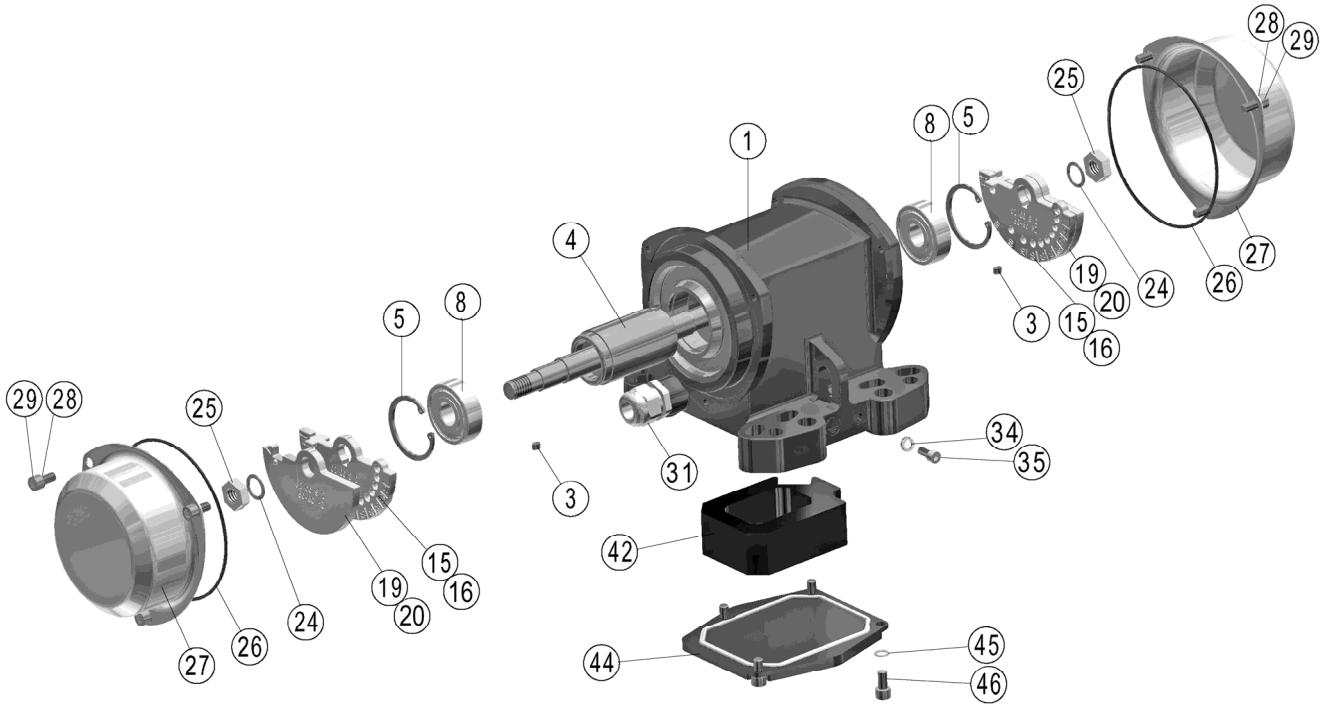

Example NEG 50200

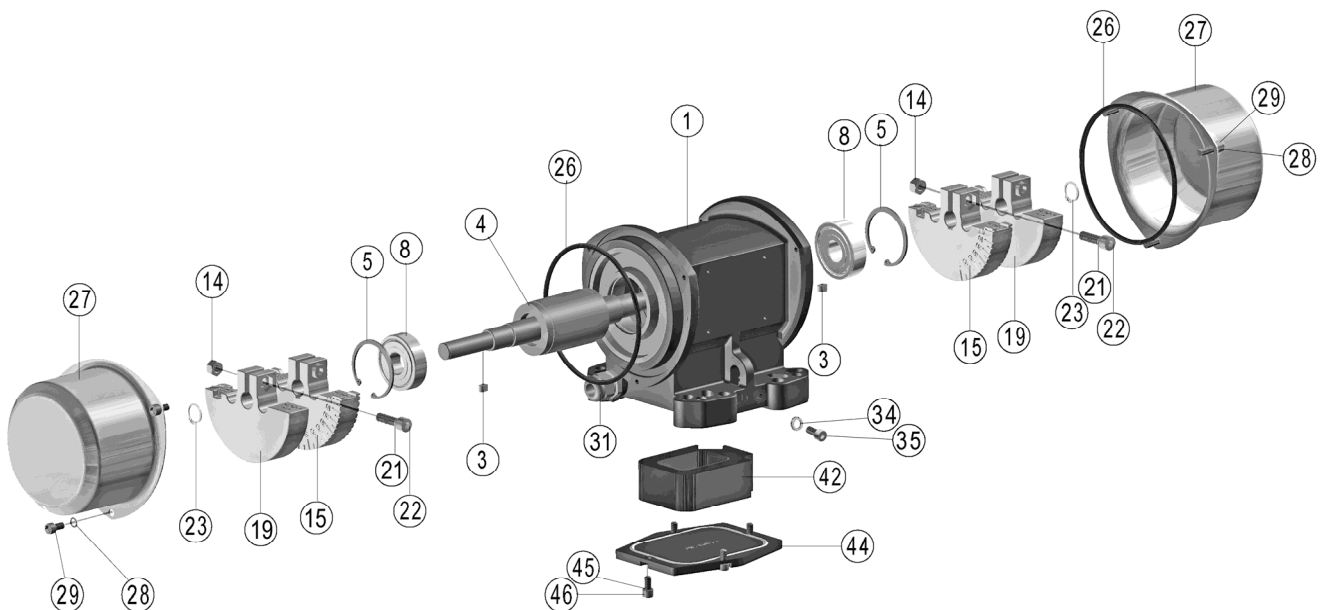

Example NEG 25210

12 Accessories

The following accessories are available for electric external vibrators of the series NEA, NED and NEG.

Description	Remark
Compensation washers	Compensation for removed unbalance discs
CC-unbalances	Two pre-adjusted working torques can be operated when changing the direction of rotation
Fastening sets NBS	for secure fastening of electric external vibrators
Frequency converters	for frequency regulated operation
Brake additives	enable a quicker braking of the vibrators
Special designs	Electric external vibrators are also available in special designs, e.g. for special voltages or for the use in explosive atmospheres. Information on request.
PTC thermistor	PTC 120°C thermistor for safe operation of the vibrators

Other electrical accessories on request.

13 Disposal

Depending on the material, the parts and packaging must be disposed of in an environmentally compatible way.

Material specifications:

	NEA	NED	NEG housing types I, II und III	NEG housing type IV
Stainless steel	Covers for unbalances	Covers for unbalances	Covers for unbalances	
Steel	Rotor, unbalance, flange, bearings, screws, washers, nuts	Rotor, unbalance, flange, bearings, screws, washers, nuts	Housing size 140 and 160, rotor, unbalance, flange, bearings, screws, washers, nuts	Rotor, unbalance, flange, bearings, screws, washers, nuts
Aluminium	Housing, name plate	Housing, type plate terminal box cover	Housing, type plate terminal box cover	Housing size 150 and 170 to 210, cover for unbalances, type plate terminal box cover
PTFE, PU, VITON	Seals, terminal box block	Seals, terminal box block	Seals, terminal box block	Seals, terminal box block
Copper with resin	Winding	Winding	Winding	Winding



ENVIRONMENTALLY FRIENDLY DISPOSAL

All units can be disposed of through Netter GmbH. The valid disposal prices are available on request.

14 Enclosures

Enclosure(s):
Declaration of manufacturer



Further information available on request: Leaflet no. 8 (Netter Electric External Vibrators), and more.