

NetterVibration

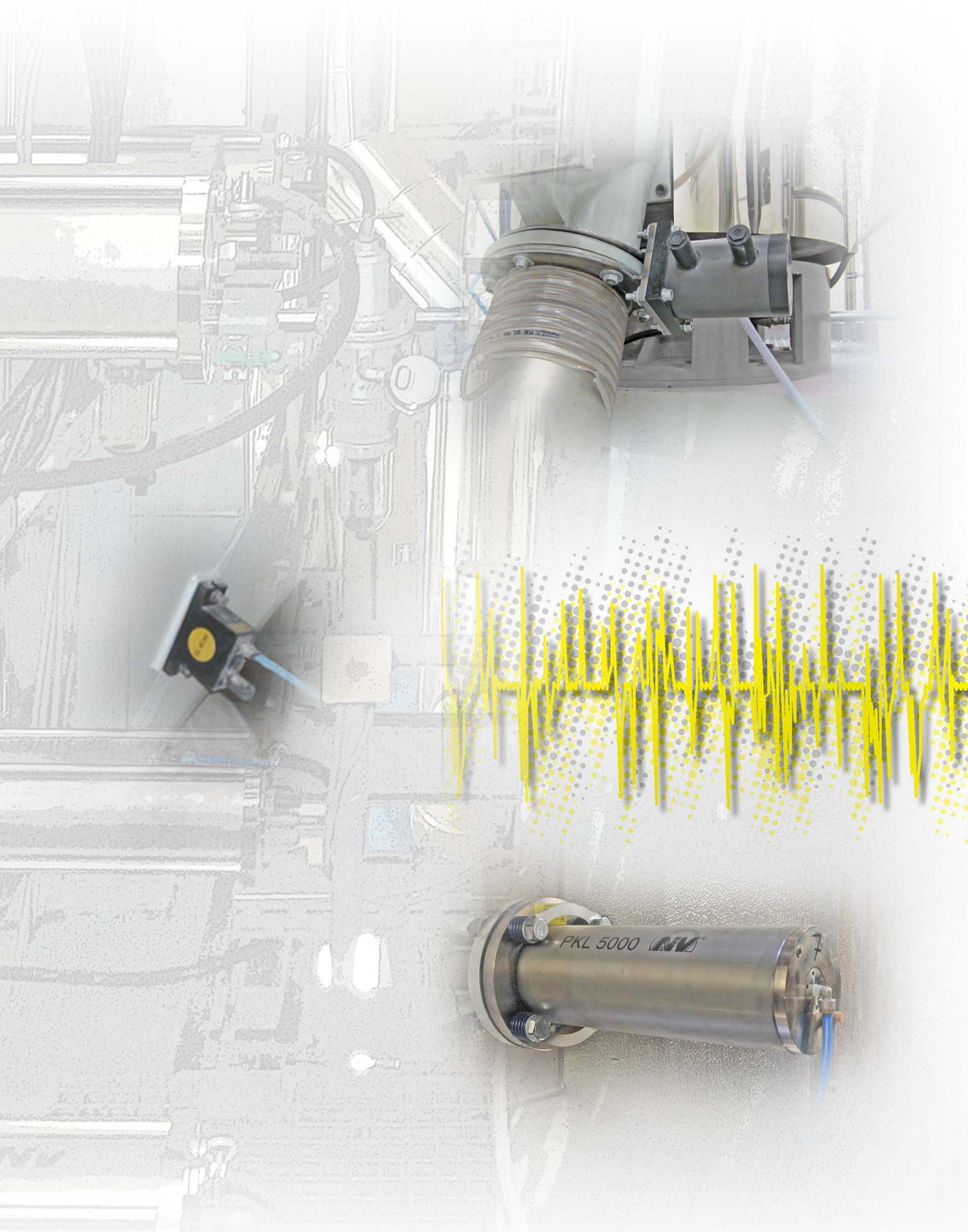

Serving industry with vibration



NetterVibration





Appliance Description

Applications

Leaflet

Pneumatic Impactors

Series PKL

- Hammer effect
- Lower compressed air requirement
- Low-noise versions available
- Versions with automatic control

- Knocking stubborn residues from walls, pipes and containers
- Preventing bridging
- Evacuating residues from weighing containers
- Preventing rat-holing



Page 5

High Frequency-Impactors

Series NHK

- Linear vibration
- High efficiency thanks to impacts
- Efficiency adjustable by vibration console

- Loosening adhering material
- Mechanical stimulation of processes
- Protection of components, long service life



Page 9

Pneumatic Linear Vibrators

Series NTS

- Linear vibration
- Frequency and amplitude can be adjusted separately
- Synchronous operation possible
- Immediate start and stop

- Conveying, compacting and loosening bulk material
- Emptying bins
- Drives for conveyor troughs
- Resistant against aggressive environmental conditions



Page 11

Pneumatic Linear Vibrators

Series NTK

- Linear vibration
- Large amplitude
- Variable additional weights
- Frequency and amplitude separately adjustable
- Immediate start and stop

- Drives for conveyor, discharge troughs
- Loosening or compacting bulk material
- Mechanical stimulation of processes
- Emptying bins
- Drive for sieves and vibrating tables



Page 15

Pneumatic Piston Vibrators

Series NTP

- Linear vibration
- Frequency and amplitude separately adjustable
- High acceleration peaks
- Rubber hammer effect

- Knocking off firmly adhering materials
- Drives for chutes and vibration tables
- Loosening product jams
- Assistance for emptying containers
- Protection of equipment by elastomer insert



Page 19

Pneumatic Rotary Vibrators

Series NCB, NCR and NCT

- Rotary vibration
- Very high centrifugal force
- Very high frequency
- Frequency continuously variable via compressed air

- Moving bulk materials
- Elimination or reduction of friction
- Emptying bins
- Preventing product jams
- Preventing adhesives to pipes and plates



Page 21 - 26

Vacuum Fixing Devices for Vibrators

Series VAC

- Flexible handling
- Easy displacement
- Frictional connection
- Integrated vacuum generation

- Use of vibrators without fixed mounting
- Use as a vibrating tool during maintenance
- Emptying transport containers
- Removing adhesions from tubes



Page 27

Electric External Vibrators

Series NEG, NEA, NED and NES

- 3-Phase, Single Phase, Direct Current
- Directional, circular vibration
- Maintenance-free operation
- NES housing completely of stainless steel
- Adjustable with Netter frequency converters

- Drives for conveyors and sieves
- Loosening adhesives and product jams
- Concrete compacting, also formwork in precast plants, tunnelling, etc.
- Compaction of different materials by using CC unbalances



Page 29 - 38

Static Adjustable Frequency Converters

Series SRF, NFI and NFU

- Infinitely adjustable speed control
- Parallel connection of multiple vibrators
- Simple and robust design
- As a standard mounted in cabinets

- Speed control for electric vibrators
- Customised versions for special applications
- Compacting and weighing bulk materials
- Vibrator control by means of CC unbalances



Page 39



Leaflet

Appliance Description

Applications



- Hydraulic External Vibrators**
Series NHG L, Series CC, CV, CCV and DV
- Driven by a hydraulic motor on board hydraulics of the carrier
 - Rotary vibration
 - Frequency continuously variable via volume flow rate

- Emptying containers and bulk hoppers
- Use on mobile machines
- Unloading transport vehicles e.g. trucks, trains and ships

Page 43 - 46



- Pneumatic External Vibrators**
Series NVT, NVR, NVG and NQT
- High frequency
 - No wear
 - No bearings
 - Quickly removable thanks to quick release brackets

- Compaction of concrete in tunnel formwork constructions
- Loosening product compaction
- Loosening stubborn adhesions
- Emptying bins
- Drives for vibrating tables

Page 47



- Vibrating Crosses**
Series NKH and NKM
- Manual or hydraulic tightening
 - Clamping device with pneumatic external vibrator
 - Continuous and effective compaction

- Compacting dry refractory mass for induction furnaces

Page 49



- Vibrating Tables**
Series VT
- Linear or circular vibration
 - Electric or pneumatic drives
 - Also for lower installation heights
 - Many ways of controls and accessories

- Compacting bulk material in cartons or sacks
- Testing component parts
- Levelling material cones
- Loosening and separating material adhesions

Page 51

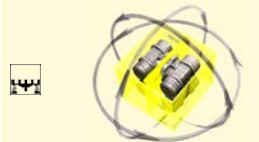

- Multiple-Shaft Vibration Systems**
Series VectorDrive
- Resonance-free start and stop
 - Amplitude adjustment during operation
 - Frequency control during operation
 - 100% controlled vibration

- Compacting
- Conveying
- Mixing
- Dispersing

Page 55



- Conveyor Systems**
Series DositPack and PowerPack
- Conveyor troughs mounted on blade springs
 - Gentle and uniform dosing
 - Adjustable fine and coarse flow
 - Immediate start and stop

- Quick and exact dosing
- Feeder for optical dosing units
- Gentle conveying and filling of bulk materials
- Stainless steel version for use in the chemical and pharmaceutical industries as well as in the food industry

Page 57 - 60



- Conveyor Systems**
Series LineDrive
- Pneumatic linear vibrator with internal guides for quick construction of a conveyor trough
 - Modularly extendable

- Gentle, horizontal conveying of bulk material
- Allows applications with confined space
- Mounting on uneven surfaces by means of a ground plate

Page 61



- Resonance Conveyor Systems**
Series FlexiLink
- Conveyor, consisting of blade springs, pneumatic linear vibrator NTK and connecting elements
 - **FlexiLink**
 - High conveying capacity
 - Immediate start and stop

- Conveyor troughs (up to 20m length)
- Fast conveying of powder and bulk materials
- Economical conveying by making use of the spring resonance

Page 63



- Hydraulic Vibrating Units**
Type NHW
- Mobile wagon emptying device
 - Quick-change connector for any carrier
 - Drive via the on-board hydraulic system of the carrier vehicle, e.g. wheel loader

- Emptying and removing adhesions from wagons

Page 67



27

Netter Pneumatic Impactors Series PKL



- Higher impact power than traditional impactors
- Lower compressed air requirement per impact
- Low-noise versions with elastomer insert EE
- Versions with automatic control ST
- ATEX or stainless steel versions available



PKL 450



PKL 740



PKL 2100



Netter Pneumatic Impactors Series PKL

Type	Piston Weight [kg]	Impact Force* [kg]	Optimum Operating Pressure [bar]	Air Requirement/Impact at Optimum Pressure [Normalliter]	Total Weight [kg]	Suitable for Wall Thickness [mm]
PKL 190/4	0,19	0,43	4,0	0,09	0,8	1 – 2
PKL 190/6	0,19	0,60	6,0	0,14	0,8	1 – 2
PKL 450/4	0,44	0,56	4,0	0,13	1,6	1 – 3
PKL 450/6	0,44	0,92	6,0	0,18	1,6	1 – 3
PKL 740/3	0,74	1,30	3,0	0,27	2,6	2 – 4
PKL 740/4	0,74	1,80	4,0	0,38	2,6	2 – 4
PKL 740/5	0,74	2,10	5,0	0,43	2,6	2 – 4
PKL 740/6	0,74	2,70	6,0	0,54	2,6	2 – 4
PKL 2100/4	2,10	4,20	4,0	1,55	6,7	3 – 5
PKL 2100/5	2,10	6,20	5,0	1,93	6,9	3 – 5
PKL 5000/4	4,96	6,60	4,0	1,50	16,0	4 – 8
PKL 5000/4 S	4,96	6,60	4,0	1,50	16,0	4 – 8
PKL 5000/6	4,96	10,60	6,0	2,20	16,5	6 – 12
PKL 5000/6 S	4,96	10,60	6,0	2,20	16,5	6 – 12
PKL 10000/6	10,00	17,50	6,0	2,60	34,0	> 10

*The impact corresponds to the given weight, when dropped from a height of 1 m.

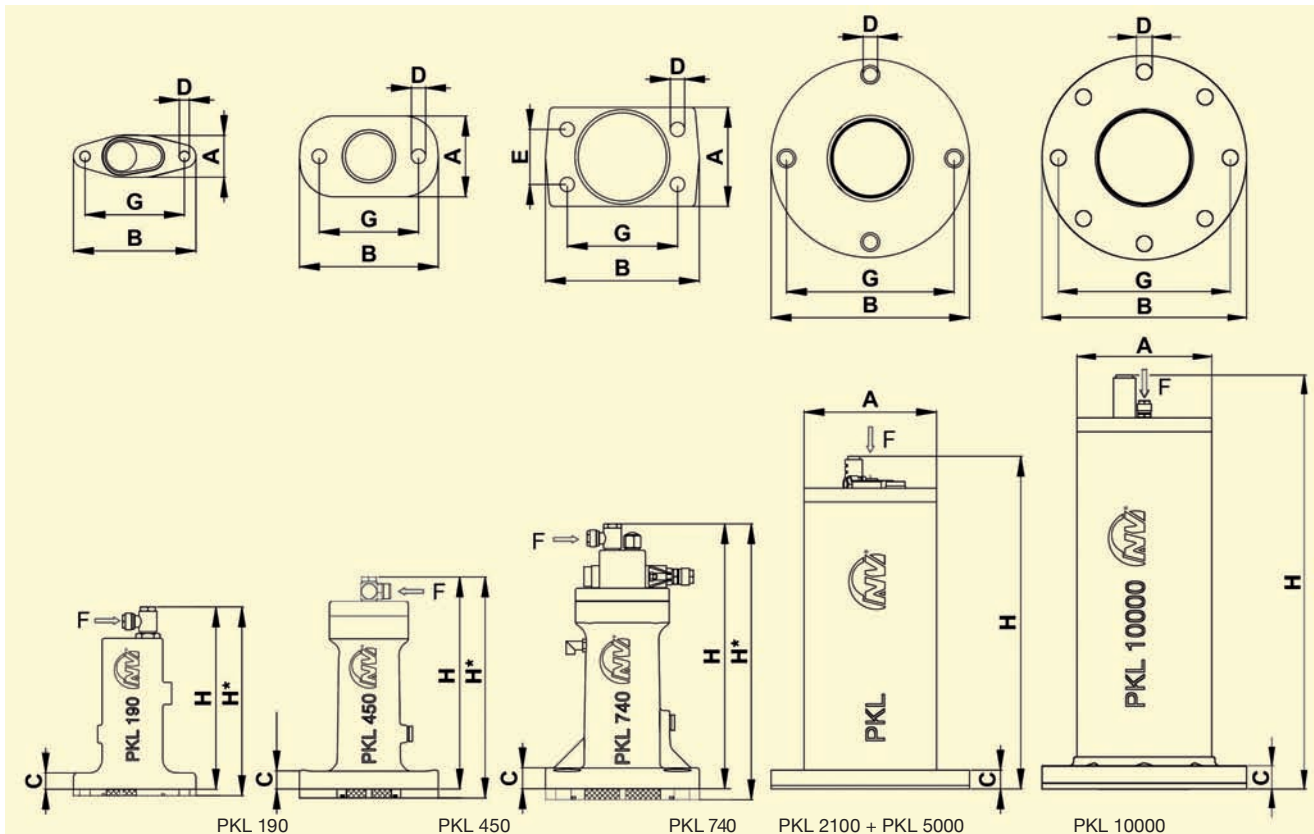

Type	A [mm]	B [mm]	C [mm]	Ø D [mm]	E [mm]	F	G [mm]	H [mm]	H* with kit EE [mm]
PKL 190	38,0	111	15	9	—	G 1/8, NW 6 × 1	90	163,5	169,5
PKL 450	73,5	126	14	13	—	G 1/8, NW 6 × 1	90	192,0	200,0
PKL 740	90,0	140	15	13	50	G 1/8, NW 6 × 1	100	238,5	248,5
PKL 2100	Ø 120,0	Ø 180	17	13	—	G 1/8, NW 6 × 1	Ø 152	300,5	—
PKL 5000	Ø 114,3	Ø 180	22	17	—	G 1/8, NW 6 × 1	Ø 152	376,5	—
PKL 10000	Ø 145,0	Ø 220	25	17	—	G 1/8, NW 6 × 1	Ø 185	445,0	—

Netter Pneumatic Impactors Series PKL



ST Kit

Applications

The ST kit enables a continuous impact sequence when connected to a permanent compressed air supply.

Impact Frequency

The impact frequency can be adjusted by means of a throttle valve installed in the air supply line. The maximum impact sequence must be observed.

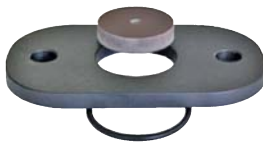

EE Kit

Applications

The EE kit is used to produce a low-noise impact or "rubber hammer effect".

Design and Function

A spacer plate with an elastomer insert, is installed between the impactor and the mounting surface of types PKL 190, 450 and 740. The existing strike plate of PKL 2100, 5000 and 10000 is replaced by an elastomer plate which reduces considerably the noise level.



Special Versions ATEX / Stainless Steel / High Temperature

PKL E (ATEX)

Netter series PKL E pneumatic impactors comply with directive 94/9/EC (ATEX product directive) device group II and are suitable for use in potentially explosive areas of category 2 (2G and 2D 85°C[T6]) in zones 1, 2, 21 and 22.

PKL S (Stainless Steel)

Stainless steel intermittent impactors satisfy the specific requirements for chemical resistance of the surfaces.

PKL HT (High Temperature)

The HT series is designed for use at ambient temperatures of up to 160°C .



Weld-On Consoles

Applications

Welding consoles ASB and welding plates ASP, available as straight or round versions, are suitable for attachment to square, round and conical containers.

They allow optimum transfer of the impulses produced by the impactor, while reducing the loads on weld seams and container walls.

Design and Function

The weld-on consoles are welded directly to the container. The impactor is then screwed to the console using fixing set NBS.



Fixing Sets NBS

Applications

NBS fixing sets provide a safe and permanent fixing of PKL impactors.

NBS fixing sets consist of special screws,

damping elements, washers and nuts, to suit the respective application.

The fixing sets are available in different executions.



Control Valves

Applications

Directional control valves are necessary for the control of impactors.

They can be activated either by hand or by means of an electronic timer.

Our product range includes electric, pneumatic and manually operated valves.



Electronic Timer AP and PAP

Applications

Electronic timers are used for the control of impactors, solenoid valves and contactors, wherever a process requires variable timing.

Design and Function

The adjustable duty time or pause time of the AP 117 has a control function by means of an electric signal (e.g. to a solenoid valve).

The pneumatic duty-pause controls (PAP 115 and PAP 116) directly control the compressed air supplied to the system and can be used in wet areas.

Controlling the duty time reduces energy consumption and noise levels.



Netter Pneumatic Impactors Series PKL



Sound protection hoods

Applications

The use of hoods is particularly worthwhile for bunkers with insulation covers.

Attaching the sound protection hood to the insulation cover fully insulates the source of the noise (bunker).



Vacuum Fixing Devices VAC

Applications

Series VAC vacuum fixing devices serve the fast fixation of impactors on smooth or, under certain circumstances, rough or curved surfaces. They allow quick and simple attachment without welding or screwing.

Design and Function

As soon as compressed air is supplied to the VAC mounting, the device is sucked tight, ensuring a force-locked connection between the impactor and the mounting surface. ATEX compliant mountings and units with stainless steel plates are available.



Cleaning pipes



Cleaning bunker walls



Cleaning weighing containers

Applications

Series PKL pneumatic impactors are particularly suitable for knocking stubborn residues from walls, pipes and containers.

Examples of applications include: elimination of tubefforming, bridging and evacuation of residues.

Design and Function

The impact (similar to a hammer) is created by the piston. With PKL 190 to 740 the impact is produced directly against the surface upon which the impactor is mounted. From PKL 2100 to PKL 5000 and PKL 10000 the piston hits the base plate. The compressed air pushes the piston against one or two springs.

The fast exhausting of the piston chamber causes the piston to strike abruptly against the impact surface. Series PKL impactors can be operated using nonlubricated compressed air. A directional control valve is necessary for activation (not included).

The maximum impact sequence is 10 impacts in a row, at a rate of 15 impacts per minute and 180 impacts per hour.

Permissible Operating Conditions:

Drive Medium:

Compressed air or nitrogen (filter $\leq 5 \mu\text{m}$), Preferably with oil mist

Operating Pressure:

2,5 bar to 6 bar

Ambient Temperature:

-20°C to 60°C

HT version up to 160°C

NetterVibration offers the accessories required for the mounting, installation, control and monitoring of vibrators and impactors.

Netter provides solutions.

Consult our experienced application technicians.

Netter GmbH

Germany

Fritz-Ullmann-Str. 9
55252 Mainz-Kastel
Tel. +49 6134 2901-0

Poland

Al. W. Korfanteo 195/17
40-153 Katowice
Tel. +48 32 2050947

Switzerland

Erlenweg 4
4310 Rheinfelden
Tel. +41 61 8316200

Spain

Errota Kalea 8
20150 Villabona-Guipúzcoa
Tel. +34 943 694 994

www.NetterVibration.com
info@NetterVibration.com



28

Netter High-Frequency Impactors Series NHK



- Linear vibration and/or impacts
- Frequency adjustable between 30 Hz and 50 Hz
- High efficiency thanks to impacts
- Temperature range between 5°C and 160°C
- Compact, closed version

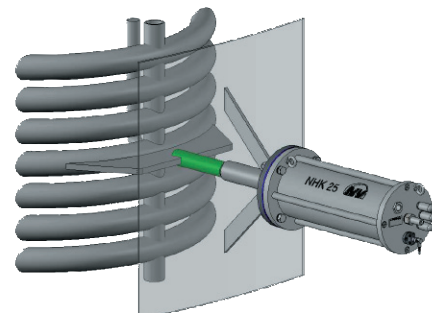
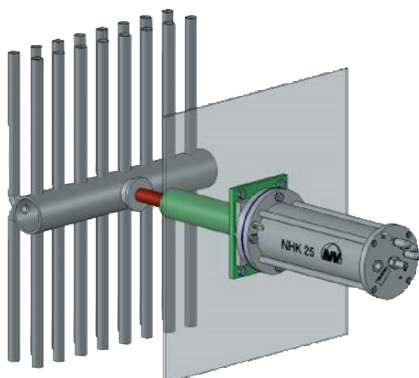

NHK 25 M 10



Netter High-Frequency Impactors Series NHK

Type	A [mm]	B [mm]	C [mm]	D [mm]	E [mm]	F [mm]
NHK 25 M 10	547	250	220	210	Ø 17	G1/2

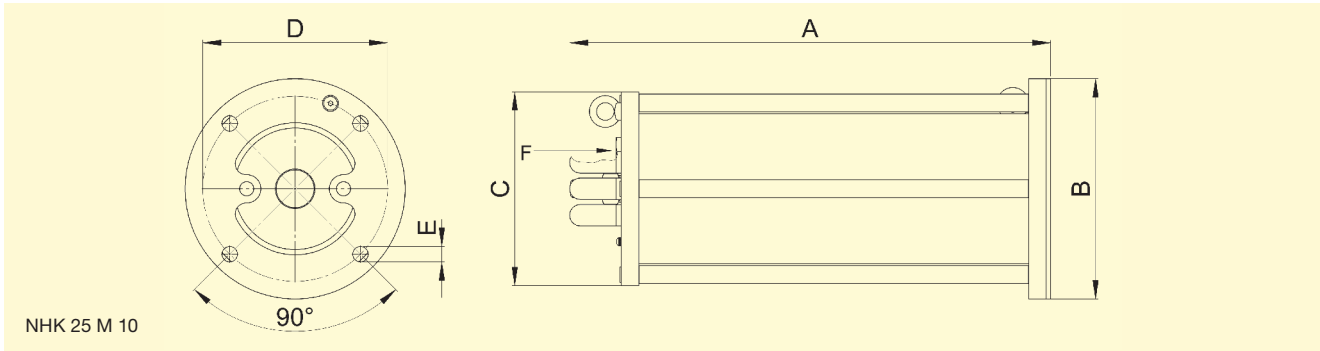

Cleaning heat exchangers (on the right: NHK with sound protection hood)

Areas of application

The high-frequency impactors of the NHK series are particularly suitable for loosening highly adherent material due to their linear vibrations. They are particularly efficient for cleaning pipes in heat exchangers and for emptying molding boxes.

Design and functioning principle

The high-frequency impactors of the NHK series generate linear vibrations and depending on the setting up to 50 impacts/second. Whereas impact cyclinders induce a relatively high amount of energy per stroke, the Netter high-frequency impactor achieves the same cleaning result by gently stroking with a significantly lower amount of energy per stroke, thus protecting the excited components and increasing their service life.

The high efficiency of the Netter high frequency impactors is achieved by the high stroke rate. The stroke frequency can be continuously adjusted during operation by using a pressure regulator. For operation a control valve is required (not included in the scope of delivery).

Sound protection hoods that are used to decrease the sound level are optionally available for the Netter high-frequency impactors.

Permissible operating conditions

Drive medium:
Compressed air or nitrogen (filter $\leq 5 \mu\text{m}$), preferably with oil mist.

Operating pressure:
2 bar to 6 bar

Ambient temperature:
5°C to 60°C
HT version up to 160°C

Special versions for operation with lubrication-free and freeze-dried compressed air are available.

NetterVibration offers the accessories required for the mounting, installation and control of vibrators and interval impactors.

Netter provides solutions. Consult our experienced application technicians.

Netter GmbH

Germany
Fritz-Ullmann-Str. 9
55252 Mainz-Kastel
Tel. +49 6134 2901-0

Poland
Al. W. Korfanteo 195/17
40-153 Katowice
Tel. +48 32 2050947

Switzerland
Erlenweg 4
4310 Rheinfelden Tel.
+41 61 8316200

Spain
Errota Kalea 8
20150 Villabona-Guipúzcoa
Tel. +34 943 694 994

www.NetterVibration.com
info@NetterVibration.com



25

Netter Pneumatic Linear Vibrators Series NTS

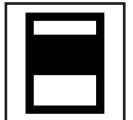

- Linear vibration
- Resistant against aggressive environmental conditions
- Nominal frequency from 827 min^{-1} to 9.040 min^{-1}
- Centrifugal force 32 N to 21.808 N
- Frequency and amplitude can be adjusted separately
- Synchronous operation possible (NTS 350 and higher)
- Available in ATEX version or in stainless steel



NTS 120 NF



NTS 54/02



NTS 50/10



Netter Pneumatic Linear Vibrators Series NTS

Type	Housing material	Working moment [cmkg]			Nominal frequency [min ⁻¹]			Centrifugal force [N]			Air consumption [l/min]		Noise level [dB(A)]	
		2 bar	4 bar	6 bar	2 bar	4 bar	6 bar	2 bar	4 bar	6 bar				
NTS 120 HF	AL	0,018	0,018	0,018	6.280	7.920	8.960	40	63	81	10	36	68	73
NTS 120 NF	AL	0,038	0,046	0,046	3.871	4.510	5.095	32	52	66	7	19	66	72
NTS 180 HF	AL	0,035	0,045	0,046	5.520	6.880	9.040	59	116	207	15	67	68	73
NTS 180 NF	AL	0,138	0,149	0,163	3.000	4.160	4.880	68	141	212	14	57	66	72
NTS 250 HF	AL	0,152	0,190	0,190	3.654	4.756	5.773	111	235	346	21	105	68	74
NTS 250 NF	AL	0,402	0,475	0,542	2.328	3.100	3.894	119	251	451	20	99	68	72
NTS 350 HF	AL	0,208	0,308	0,349	3.866	4.754	5.579	179	399	594	37	135	66	74
NTS 350 NF	AL	0,756	0,932	0,992	2.412	3.077	3.663	241	486	733	26	110	65	70
NTS 100/01*	AL	0,33	0,43	0,41	3.920	4.640	5.840	281	513	764	33	181	68	80
NTS 75/01*	AL	1,01	1,31	1,44	2.848	3.596	4.038	451	934	1.291	99	442	67	81
NTS 50/01*	AL	2,18	2,62	2,66	1.924	2.408	2.825	442	834	1.164	88	416	76	84
NTS 70/02*	AL	2,81	2,77	3,04	2.096	2.808	3.336	676	1.186	1.847	128	564	76	87
NTS 54/02*	AL	4,54	5,51	5,07	1.730	2.064	2.544	745	1.288	1.800	152	698	80	89
NTS 50/04*	AL	7,9	9,8	9,7	1.920	2.296	2.672	1.591	2.844	3.789	271	977	77	86
NTS 21/04	AL	34,9	45,9	49,1	941	1.156	1.334	1.694	3.362	4.786	225	718	73	83
NTS 50/08*	AL	11,3	15,3	17,0	1.977	2.331	2.669	2.426	4.555	6.642	216	803	81	90
NTS 50/10	GG	14,5	17,9	18,9	1.983	2.392	2.809	3.128	5.626	8.174	454	1.647	82	92
NTS 30/10	GG	50,0	80,0	96,0	840	1.044	1.300	1.940	4.780	8.900	312	1.438	75	85
NTS 50/15	GG	25,0	32,7	35,8	1.830	2.209	2.464	4.589	8.754	11.922	726	2.108	81	91
NTS 50/20	GG	24,7	34,2	37,3	1.823	2.252	2.591	4.511	9.527	13.737	887	2.491	81	92
NTS 30/20	GG	57,3	84,8	92,6	1.227	1.528	1.759	4.727	10.852	15.693	551	2.014	78	88
NTS 24/20	GG	94,2	126,6	144,8	936	1.176	1.388	4.515	9.596	15.290	642	2.083	75	80
NTS 50/40	GG	72,5	93,0	99,5	1.335	1.617	1.920	7.090	13.333	20.114	994	3.296	80	92
NTS 20/40	GG	218,9	286,7	302,3	827	985	1.147	8.227	15.239	21.808	1.340	4.252	77	89

The technical data can vary depending on application. Please request comparative values.

* oil free operation possible

Standard vibrators
NTS 120 bis NTS 350



Standard vibrators
NTS 100/01 bis NTS 20/40



Stainless steel vibrators
NTS S



ATEX compliant vibrators
NTS E

Netter Pneumatic Linear Vibrators Series NTS



Type	A [mm]	A ₁ [mm]	B [mm]	C [mm]	D [mm]	ØE [mm]	F [mm]	G [mm]	H [mm]	I [mm]	K Outlet	L Inlet	Outlet on side	Housing [kg]	Piston [kg]	Total [kg]	Housing type
NTS 120 HF	97,5	70,0	27,5	SW 21	-	M 8	11	16,5	34,5	-	G1/8	G1/8	-	0,086	0,022	0,108	I
NTS 120 NF	125,0	97,5	27,5	SW 21	-	M 8	11	16,5	48,5	-	G1/8	G1/8	-	0,119	0,042	0,161	I
NTS 180 HF	108,5	73,0	33,5	SW 27	-	M10	10	19,5	35,5	-	G1/4	G1/8	-	0,124	0,050	0,174	I
NTS 180 NF	146,5	110,5	33,5	SW 27	-	M10	10	19,5	53,8	-	G1/4	G1/8	-	0,192	0,110	0,302	I
NTS 250 HF	145,5	98,0	41,5	SW 36	-	M12	12	24,0	49,0	-	G3/8	G1/8	-	0,238	0,155	0,393	I
NTS 250 NF	190,0	141,0	41,5	SW 36	-	M12	12	24,0	70,5	-	G3/8	G1/8	-	0,335	0,290	0,625	I
NTS 350 HF	146,5	99,0	53,0	SW 46	-	M12	12	30,5	49,5	-	G3/8	G1/4	-	0,359	0,325	0,684	I
NTS 350 NF	193,0	145,0	53,0	SW 46	-	M12	12	30,5	72,5	-	G3/8	G1/4	-	0,505	0,570	1,075	I

NTS 100/01	89	-	Ø69	69	-	M12	20	65,5	48,5	31,5	G1/4	G1/4	3	0,64	0,36	1,0	II
NTS 75/01	115	-	90	80	72	9	20	81	60	38	G1/4	G1/4	2	1,1	0,8	1,9	II
NTS 50/01	155	-	90	80	72	9	20	121	80	40	G1/4	G1/4	2	1,5	1,4	2,9	II
NTS 70/02	130	-	110	100	90	9	20	91	65	39	G3/8	G3/8	2	1,9	1,2	3,1	II
NTS 54/02	157	-	110	100	90	9	20	112	79	45	G3/8	G3/8	2	2,3	1,6	3,9	II
NTS 50/04	157	-	150	139	124	13	20	113	79	44	G3/8	G3/8	2	4,0	4,3	8,3	II
NTS 21/04	330	-	150	139	124	13	20	280	165	49	G3/8	G3/8	2 + 4	8,5	12,5	21	III
NTS 50/08	173	-	200	170	165	17	30	125	92	58	G3/8	G3/8	2 + 4	9,0	7,1	16,1	III

NTS 50/10	157	-	200	190	165	18	20	112	79	45	G3/8	G1/2	2 + 4	20	9,0	29	III
NTS 30/10	340	-	200	190	165	18	20	289	170	52	G3/8	G1/2	2 + 4	41	25	66	III
NTS 50/15	185	-	230	220	190	22	30	134	95	56	G3/8	G3/4	1 - 4	32	15	47	III
NTS 50/20	190	-	250	250	210	22	30	134	95	57	G3/8	G3/4	1 - 4	42	19	61	III
NTS 30/20	278	-	250	250	210	22	30	218	139	61	G3/8	G3/4	1 - 4	54	37	91	III
NTS 24/20	360	-	250	250	210	22	30	298	180	62	G3/8	G3/4	1 - 4	68	54	122	III
NTS 50/40	266	-	320	320	260	26	40	194	133	72	G1/2	G 1	1 - 4	89	52	141	III
NTS 20/40	470	-	320	320	260	25	40	392	235	78	G1/2	G 1	1 - 4	134	125	259	III

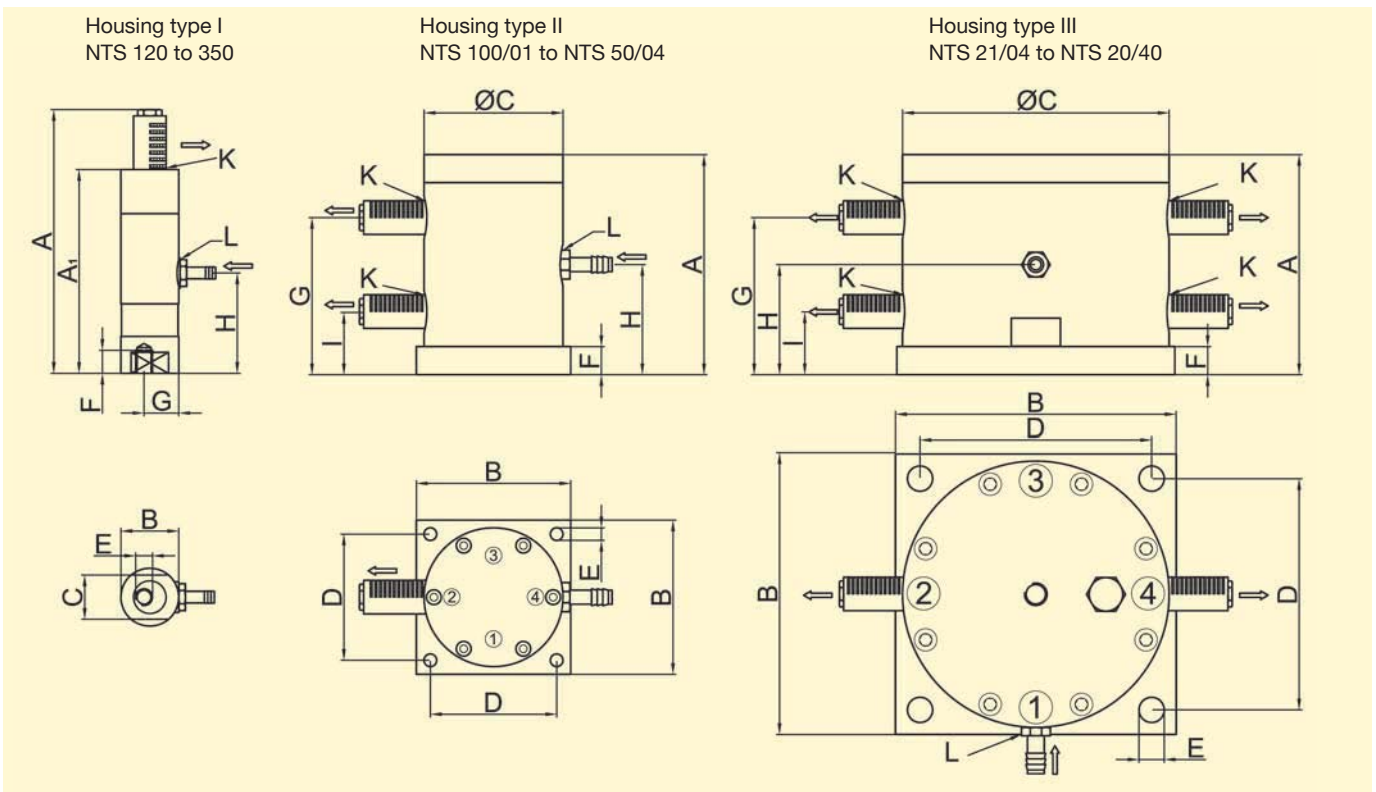



Netter Pneumatic Linear Vibrators Series NTS



Filling of powder products



Maintaining material flow



Vibrating and compacting of various material in cartons



Discharging aid on the container



Conveying with Netter **PowerPack**



Compaction of form sand in foundry forms



Compaction of powder in sacks

Applications

The pneumatic linear vibrators series NTS are especially suitable for conveying, compacting and loosening bulk material, due to the completely linear vibration.

They are used to empty bins and as drives for conveyor and dosing troughs. A special feature of NTS vibrators is the possibility of the synchronous operation of several NTS when using a coupling kit. Starting from NTS 350 NF to NTS 50/08 this is available as special execution and starting from NTS 50/10 to NTS 20/40 it is standard.

Design and functioning principle

The vibration (sinus-shaped oscillation) is produced by a freely vibrating, self reversing piston. This oscillation supports, expedites or enables a variety of applications. NTS linear vibrators start and stop without delay in any installed position.

A built-in pressure spring provides a reliable start-up of vibrators with aluminium housing up to NTS 50/04 and NTS 50/08. The amplitude is set by means of the optional throttle valve.

An increase of the supply pressure causes a higher frequency. For operation a control valve is required (not included in scope of delivery). ATEX compliant linear vibrators of the NTS series and units with a stainless steel housing are available.

Permissible operating conditions

Drive medium:

Compressed air or nitrogen (Filter $\leq 5 \mu\text{m}$), preferably with oil mist

Operating pressure:

2 bar to 6 bar

Ambient temperature:

-10°C to 60°C

Aluminium housing 5°C to 60°C

NetterVibration offers the accessories required for the mounting, installation, control and monitoring of vibrators and impactors.

Netter provides solutions.

Consults our experienced application technicians.

Netter GmbH

Germany

Fritz-Ullmann-Str. 9
55252 Mainz-Kastel
Tel. +49 6134 2901-0

Poland

Al. W. Korfantego 195/17
40-153 Katowice
Tel. +48 32 2050947

Switzerland

Erlenweg 4
4310 Rheinfelden
Tel. +41 61 8316200

Spain

Errota Kalea 8
20150 Villabona-Guipúzcoa
Tel. +34 943 694 994

www.NetterVibration.com
info@NetterVibration.com



24

Netter Pneumatic Linear Vibrators Series NTK



- Linear vibration
- Nominal frequency from 519 min⁻¹ to 3.800 min⁻¹
- Centrifugal force from 14 N to 4.748 N
- Variable additional weights
- Frequency and amplitude are separately adjustable
- Stainless steel version available
- Ex II 2 GD 85°C (T6) available (ATEX)



NTK 8 AL



NTK 25



NTK 55 AL



Netter Pneumatic Linear Vibrators Series NTK

The table shows the most frequent ratings of piston vibrators series NTK.

1 "Piston" means, that the piston vibrates, the housing is bolted to the mass to be operated.

2 The additional weights SM increase the mass of the piston and in consequence the amplitude.

3 "Housing" in the table means that the vibrator is fixed to the piston and allows additional combinations.

4 Some vibrators may be fitted with additional weights SM at the housing.

Methods of attachment

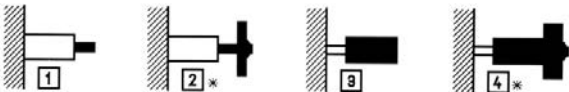

*In case of horizontal mounting with weights, please pay particular attention to the operating manual!

Type	Oscillating part		Working moment [cmkg]			Nominal frequency [min ⁻¹]			Centrifugal force [N]			Air consumption [l/min]**	Noise level [dB(A)]
	Assembly	Mass [kg] **	2 bar	4 bar	6 bar	2 bar	4 bar	6 bar	2 bar	4 bar	6 bar	2 bar - 6 bar	2 bar - 6 bar
NTK 8 AL*	Piston	0,030	0,05	0,06	0,06	2.440	3.120	3.657	15	32	44	7 - 32	61 - 75
	Piston + SM 8-1	0,046	0,08	0,10	0,10	1.858	2.412	3.000	16	32	48	6 - 31	
	Piston + 2 x SM 8-1	0,058	0,09	0,14	0,15	1.680	2.100	2.571	14	33	54	6 - 29	
	Piston + SM 8-2	0,088	0,15	0,37	0,21	1.380	1.333	2.080	15	36	50	6 - 25	
NTK15 x*	Piston	0,135	0,29	0,33	0,29	1.745	2.182	2.544	49	85	104	17 - 72	53 - 64
	Piston + SM 16-1	0,455	0,81	1,17	1,27	1.029	1.137	1.343	47	83	126	16 - 57	
	Piston + SM 16-2	0,675	1,69	1,95	1,69	758	917	1.152	53	90	123	14 - 54	
NTK16	Piston	0,150	0,27	0,37	0,34	1.680	1.920	2.400	42	75	106	14 - 58	54 - 67
	Piston + SM 16-1	0,470	1,14	1,48	1,48	908	1.309	1.527	52	139	189	11 - 44	
	Piston + SM 16-1 + SM 16-2	0,990	2,96	3,02	2,96	686	914	1.085	76	139	191	8 - 41	
	Housing	1,330	4,90	4,60	4,50	600	778	923	96	153	210	8 - 39	
NTK18 AL*	Piston	0,210	0,29	0,33	0,36	1.600	1.980	2.350	41	70	109	19 - 68	55 - 68
	Piston + SM 16-1	0,530	1,18	1,47	1,41	972	1.321	1.572	61	141	191	13 - 58	
	Piston + SM 16-2	0,750	1,96	2,29	2,16	878	1.168	1.371	83	171	223	11 - 56	
	Piston + SM 16-1 + SM 16-2	1,050	3,27	3,27	3,21	738	965	1.174	98	167	242	10 - 50	
NTK25 AL*	Piston + 2 x SM 16-2	1,270	3,86	4,13	3,93	702	902	1.039	104	184	233	9 - 46	56 - 73
	Piston	0,420	1,18	1,38	1,24	1.289	1.821	1.986	107	250	269	34 - 149	
	Piston + SM 25-1	0,775	2,59	2,95	2,88	988	1.371	1.622	139	304	415	26 - 138	
	Piston + SM 25-2	0,970	3,54	3,86	3,67	894	1.237	1.477	155	324	439	24 - 127	
	Piston + SM 25-3	1,655	6,88	6,94	6,55	686	898	1.080	177	307	419	22 - 115	
NTK25	Piston + 2 x SM 25-3	2,840	11,79	11,46	11,13	540	823	943	188	425	543	21 - 104	57 - 73
	Piston	0,470	1,12	1,36	1,32	1.440	1.946	2.270	127	282	374	38 - 156	
	Piston + SM 25-3	1,705	5,58	6,41	6,34	800	988	1.292	196	343	581	25 - 105	
	Housing	2,600	9,10	9,95	9,82	690	911	1.067	237	452	612	24 - 102	
	Housing + SM 25-3	3,835	11,45	14,07	13,74	609	780	933	233	469	656	23 - 100	
NTK28 AL*	Housing + 2 x SM 25-3	5,020	14,40	18,00	17,67	565	738	825	252	538	660	20 - 99	56 - 72
	Piston	0,590	2,10	2,20	2,10	1.488	1.710	1.818	255	353	381	38 - 135	
	Piston + SM 16-1	0,910	3,06	2,92	2,89	1.230	1.482	1.602	254	352	407	32 - 133	
	Piston + SM 16-2	1,130	3,55	3,81	3,48	1.110	1.374	1.488	240	395	423	30 - 136	
NTK40 AL*	Piston + 2 x SM 16-2	1,640	5,13	5,09	4,93	960	1.164	1.290	259	378	450	30 - 122	58 - 70
	Piston	1,240	2,88	2,64	2,16	1.231	1.620	2.094	239	380	519	54 - 220	
	Piston + SM 25-3	2,475	6,72	8,40	7,44	900	1.168	1.389	298	628	787	36 - 210	
	Piston + 2 x SM 25-3	3,660	13,08	13,20	12,96	710	923	1.169	361	617	971	34 - 173	
NTK40 NF	Piston + SM 25-4	4,910	24,24	20,64	18,72	565	780	985	424	689	995	33 - 152	58 - 70
	Piston	1,270	3,57	3,57	2,46	1.200	1.629	1.930	282	520	503	49 - 228	
	Piston + SM 25-3	2,505	7,39	8,62	8,50	889	1.175	1.433	320	653	957	38 - 188	
	Housing	4,200	19,48	17,08	16,36	600	840	1.108	385	661	1.100	34 - 161	
NTK40 HF	Housing + SM 25-3	5,435	33,44	26,34	21,65	519	738	933	494	788	1.034	29 - 145	63 - 76
	Piston	1,270	2,90	2,84	2,53	1.857	1.887	2.475	548	554	851	40 - 151	
NTK55 AL*	Piston + SM 25-3	2,505	6,29	7,22	6,97	1.038	1.230	1.476	372	599	833	28 - 134	62 - 71
	Piston	2,100	3,62	3,50	2,66	1.500	1.920	2.400	447	708	839	98 - 398	
	Piston + SM 85-1	3,430	7,25	7,25	6,28	1.113	1.440	1.768	492	824	1.077	83 - 384	
	Piston + 2 x SM 85-1	4,610	11,11	10,87	9,90	985	1.292	1.500	591	995	1.222	81 - 371	
	Piston + SM 85-2	5,870	14,49	14,49	13,28	884	1.175	1.371	621	1.097	1.370	79 - 366	
	Piston + 2 x SM 85-1+ SM 85-2	8,285	22,94	22,22	20,29	758	1.011	1.200	723	1.244	1.602	73 - 355	

Type	Oscillating part		Working moment [cmkg]			Nominal frequency [min ⁻¹]			Centrifugal force [N]			Air consumption [l/min]**	Noise level [dB(A)]
	Assembly	Mass [kg]**	2 bar	4 bar	6 bar	2 bar	4 bar	6 bar	2 bar	4 bar	6 bar	2 bar – 6 bar	2 bar – 6 bar
NTK 55 NF	Piston	2,100	4,08	3,60	2,88	1.405	1.879	2.351	441	696	872	101 – 408	62 – 71
	Piston + 2 x SM 85 - 1	4,610	11,03	11,75	10,55	973	1.358	1.611	573	1.189	1.501	69 – 345	
	Housing	5,900	14,40	15,09	13,47	884	1.206	1.467	617	1.204	1.588	64 – 330	
	Piston + SM 85 - 1 + SM 85 - 2	7,050	18,94	19,66	18,22	853	1.140	1.380	755	1.401	1.903	63 – 321	
	Piston + SM 85 - 3	14,630	41,37	41,97	41,97	677	862	1.015	1.039	1.708	2.371	62 – 317	
Housing + SM 85 - 3	18,430	46,44	52,25	49,92	649	823	960	1.071	1.940	2.523	61 – 286		
NTK 55 HF	Piston	2,100	2,49	2,74	2,49	1.760	2.352	2.836	423	831	1.099	65 – 295	64 – 74
	Piston + SM 85 - 2	3,430	4,98	6,35	6,11	1.380	1.705	2.050	520	1.013	1.407	53 – 291	
NTK 85 NF	Piston	5,200	3,91	4,67	5,04	1.892	2.400	2.830	767	1.474	2.215	166 – 545	61 – 76
	Piston + SM 85 - 1	6,530	6,31	6,56	6,56	1.622	2.108	2.514	910	1.597	2.273	167 – 544	
	Piston + SM 85 - 2	8,970	9,58	10,09	10,09	1.345	1.714	2.067	950	1.626	2.364	159 – 536	
	Housing	12,100	13,59	14,07	13,11	1.200	1.543	1.838	1.073	1.836	2.428	148 – 532	
	Piston + SM 85 - 3	17,500	25,47	26,48	24,21	894	1.166	1.407	1.116	1.975	2.627	128 – 513	
	Piston + SM 85 - 2 + SM 85 - 3	21,000	32,16	32,79	30,89	821	1.060	1.297	1.187	2.021	2.851	120 – 505	
	Piston + SM 85 - 4	28,900	45,40	51,70	45,40	707	879	1.076	1.244	2.191	2.880	111 – 494	
Piston + SM 85 - 5	40,750	69,36	75,66	73,14	592	784	914	1.333	2.548	3.352	103 – 452		
NTK 85 HF	Piston	5,200	3,01	3,76	3,88	2.520	3.120	3.800	1.047	2.006	3.075	118 – 431	64 – 79
	Piston + 2 x SM 85 - 1	7,710	5,01	6,39	6,27	2.031	2.466	2.954	1.133	2.130	2.997	120 – 446	
NTK 110	Piston	8,000	6,03	7,87	7,87	2.133	2.571	3.040	1.505	2.852	3.986	210 – 652	62 – 78
	Piston + SM 85 - 2	11,770	9,18	11,27	11,80	1.760	2.160	2.538	1.559	2.884	4.169	209 – 650	
	Housing	16,600	13,48	15,68	15,93	1.447	1.846	2.133	1.548	2.930	3.974	207 – 634	
	Piston + SM 85 - 3	20,530	17,04	19,93	20,98	1.324	1.655	1.964	1.638	2.993	4.435	206 – 631	
	Piston + SM 85 - 2 + SM 85 - 3	24,090	21,24	23,60	24,65	1.200	1.527	1.821	1.677	3.018	4.480	203 – 628	
	Piston + SM 85 - 4	31,990	29,89	32,78	32,51	1.046	1.292	1.632	1.794	3.001	4.748	191 – 614	
Piston + SM 85 - 5	44,455	38,67	44,57	41,95	900	1.143	1.371	1.718	3.192	4.326	180 – 606		

* For lubrication free operation contact our application technicians. Subject to technical modifications.
 ** All weights inclusive fixing bolt. *** Normal litre = uncompressed air, NTK 16, 25, 40, 55, 85 and 110 operation is possible up to 16 bar.
 Technical data may vary depending on application. Please request comparative values.

NTK weights

Piston, housing, total weight

Vibrator	Piston [kg]	Housing [kg]	Total weight [kg]	Possible combinations	Additional weights	Dimensions [Ømm x mm]	Bore [Ømm]	Weight [kg]
NTK 8 AL	0,03	0,06	0,09	All combinations	SM 8 - 1	17 x 8	5,0	0,012
					SM 8 - 2	30 x 10	5,0	0,053
NTK 15 x	0,13	0,32	0,45	of vibrators and weights within the same	SM 16 - 1	50 x 20	10,5	0,29
NTK 16	0,15	1,34	1,49		SM 16 - 2	65 x 20	10,5	0,51
NTK 18 AL	0,21	0,53	0,74					
NTK 28 AL	0,59	0,60	1,19	group are possible.				
NTK 25 AL	0,43	0,50	0,92		SM 25 - 1	50 x 20	16,5	0,27
NTK 25	0,47	2,63	3,10		SM 25 - 2	65 x 20	16,5	0,47
NTK 40 AL	1,28	1,01	2,29		SM 25 - 3	100 x 20	16,5	1,18
NTK 40 NF	1,29	4,20	5,49		SM 25 - 4	100 x 60	16,5	3,60
NTK 40 HF	1,27	4,38	5,65	Siehe table page 2 and page 3.				
NTK 55 AL	2,10	1,75	3,85		SM 85 - 1	100 x 20	20,5	1,16
NTK 55 NF	2,10	5,90	8,00		SM 85 - 3	200 x 50	20,5	12,30
NTK 55 HF	2,10	5,60	7,70		SM 85 - 2	100 x 60	20,5	3,50
NTK 85 NF	5,20	12,10	17,30		SM 85 - 4	200 x 100	20,5	22,70
NTK 85 HF	5,20	11,30	16,50	SM 85 - 5	200 x 150	20,5	35,55	
NTK 110	8,00	16,60	24,60					

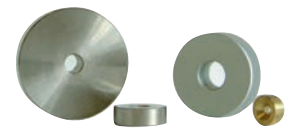

Applications
 Additional weights SM are used to increase the working moment. While fixing additional weights on the moving part of the vibrator, the working moment and also the amplitude are individually adjustable. The additional weights are available in different sizes. All weights are made of nickel plated steel, except SM 8-1 which is made of brass.

Netter Bellows

Series NFB

Bellow	Vibrator	Inside diameter [mm]	Outside diameter [mm]
NFB 20	NTK 15 x, 16, 18 AL	20	50
NFB 25	NTK 25 AL	30	65
NFB 30	NTK 25	30	65
NFB 45	NTK 40	45	85
NFB 60	NTK 55	60	110
NFB 90	NTK 85	90	140
NFB 115	NTK 110	115	165

Applications

The bellows series NFB for linear vibrators series NTK are designed for the protection of the piston against outside influences such as dirt and dust. NFB bellows are available for all types from NTK 15x up to NTK 110. They are easily removable by velcros and make the flats of the piston accessible. For NTK 8 AL a protection cap that is to be screwed onto the device is available.





Netter Pneumatic Linear Vibrators Series NTK

Type	ØA [mm]	ØB [mm]	C [mm]	E [mm]	F [mm]	G* [mm]	H	ØJ [mm]	ØK [mm]	L	M	ØQ** [mm]	R [mm]	S [mm]	T [mm]	U [mm]	SW [mm]
NTK 15 x	15	50	114	9	38	23,5	M10	-	-	G 1/8	G 1/8	-	20	10	55	99	13
NTK 16	16	49	111	5	38	21,5	M10	-	-	G 1/8	G 1/8	-	21	10	57	96	14
NTK 18 AL	18	49	116	8	42	25,0	M10	-	-	G 1/8	G 1/8	-	21	10	62	101	16
NTK 25	25	64	138	9	52	30,5	M16	-	-	G 1/4	G 1/4	-	25	10	73	125	22
NTK 40	40	84	140	12 ¹	54	33,0	M16	-	-	G 3/8	G 1/4	-	40	15	73	123	32
NTK 55 NF	55	110	125	17	50	35,0	M20	96	-	G 3/8	G 3/8	4 x 8,5	40	30	60	108	46
NTK 55 HF	55	110	115	27	50	40,5	M20	96	-	G 3/8	G 3/8	4 x 8,5	40	30	50	98	46
NTK 85 NF	85	160	122	20	50	32,5	M20	143	12,8	2 x G 3/8	G 3/8	6 x 10,5	40	20	57	105	-
NTK 85 HF	85	160	112	30	55	42,5	M20	143	12,8	2 x G 3/8	G 3/8	6 x 10,5	40	20	47	95	-
NTK 110	110	200	122	22	55	38,5	M20	182	12,8	2 x G 1/2	2 x G 3/8***	8 x 12,5	40	25	57	105	-

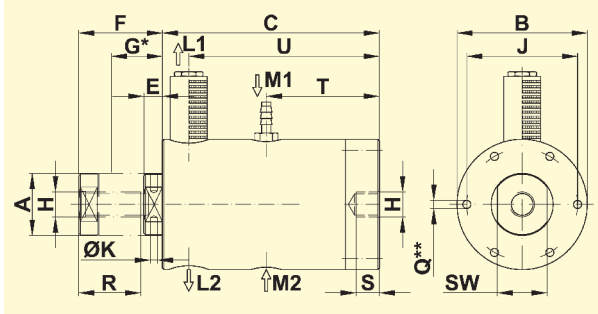

¹ NTK 40 HF: 22 mm
 * centre of vibration
 ** additional form of attachment from NTK 55 upwards
 *** optional M₁ or M₂

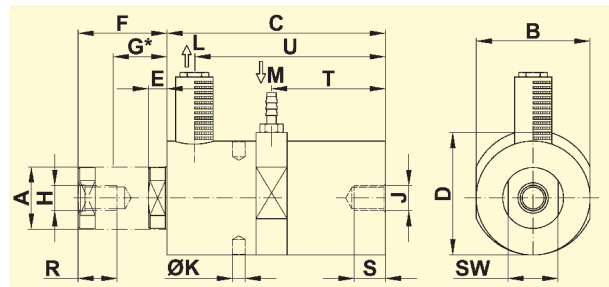

Type	ØA [mm]	B [mm]	C [mm]	D [mm]	E [mm]	F [mm]	G* [mm]	H	J	ØK [mm]	L	M	R [mm]	S [mm]	T [mm]	U [mm]	SW [mm]
NTK 8 AL	8	17	91	22	5	32	18,5	M 5	M 6	-	M 5	M 5	15	7	47	76,5	7
NTK 25 AL	25	50	138	54	7	52	29,5	M 16	M 16	-	G 1/4	G 1/4	25	18	72	120,5	22
NTK 28 AL	28,5	50	160	54	15	53	31,5	M 10	M 16	-	G 1/4	G 1/4	20	22	94	143,0	24
NTK 40 AL	40	73	140	79	12	57	34,5	M 16	M 16	8	G 3/8	G 1/4	25	20	73	122,5	32
NTK 55 AL	55	98	133	109	20	58	38,5	M 20	M 20	10	G 3/8	G 3/8	40	35	66	115,0	46

* centre of vibration

Applications

The pneumatic linear vibrators series NTK are especially suitable for conveying, compacting and loosening bulk material, due to the completely linear vibration. They may also serve to stimulate and influence production processes.

A special feature of the NTK vibrators is the variety of mounting options. It is possible to attach the housing or the piston to a vibrating mass. Additional weights SM allow to adjust the frequency and the amplitude in many different ways.

Design and functioning principle

The vibration (linear) is produced by a freely oscillating, self reversing piston. NTK linear vibrators start and stop instantly in any installed position. The noise level is lower than 80 dB(A). The frequency can be adjusted continuously by regulating the air supply. The amplitude can be adjusted by throttling the exhaust air.

Vibrators with aluminium housing series NTK AL as well as type NTK 15x may be operated lubrication-free in compliance with instructions

of **NetterVibration**. NTK vibrators with steel housing require lubricated air. For operation a control valve is required (not included in scope of delivery). ATEX compliant linear vibrators of the NTK series and units with stainless steel housing are available.

Permissible operating conditions

Drive medium:

Compressed air or nitrogen (Filter ≤ 5 µm), preferably with oil mist

Operating pressure:

2 bar to 6 bar

Ambient temperature:

NTK AL 5°C to 60°C

NTK 15 x 5°C to 100°C

NTK with steel housing -10°C to 150°C

HT version up to 200°C

NetterVibration offers the accessories required for the mounting, installation, control and monitoring of vibrators and impactors.

Netter provides solutions.

Consult our experienced application technicians.

Netter GmbH

Germany

Fritz-Ullmann-Str. 9
 55252 Mainz-Kastel
 Tel. +49 6134 2901-0

Poland

Al. W. Korfantego 195/17
 40-153 Katowice
 Tel. +48 32 2050947

Switzerland

Erlenweg 4
 4310 Rheinfelden
 Tel. +41 61 8316200

Spain

Errota Kalea 8
 20150 Villabona-Guipúzcoa
 Tel. +34 943 694 994

www.**NetterVibration.com**
 info@**NetterVibration.com**



26

Netter Pneumatic Piston Vibrators Series NTP

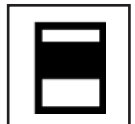

- Linear vibration
- Nominal frequency from 1.328 min⁻¹ to 8.784 min⁻¹
- Centrifugal force from 190 N to 2.039 N
- Frequency and amplitude are adjustable separately
- Available in ATEX compliant or in stainless steel



NTP 25



NTP 32



NTP 48



Netter Pneumatic Piston Vibrators Series NTP

Type	Working moment [cmkg]			Nominal frequency [min ⁻¹]			Centrifugal force [N]			Air consumption [l/min]	Noise level [dB(A)]
	2 bar	4 bar	6 bar	2 bar	4 bar	6 bar	2 bar	4 bar	6 bar	2 bar – 6 bar	2 bar – 6 bar
NTP 25 B+C	0,144	0,163	0,196	5.848	7.000	8.784	269	438	830	33 – 108	68 – 82
NTP 25 B	0,488	0,613	0,686	2.645	3.159	3.602	190	341	487	23 – 92	64 – 73
NTP 32 B+C	0,602	0,665	0,665	2.959	4.080	5.040	289	607	926	50 – 198	71 – 86
NTP 32 B	1,080	1,365	1,449	1.824	2.221	2.614	197	369	543	37 – 143	64 – 77
NTP 48 B+C	2,081	1,992	1,992	2.618	3.456	4.320	782	1.305	2.039	96 – 336	78 – 90
NTP 48 B	4,718	6,188	6,641	1.328	1.603	1.963	456	872	1.403	67 – 295	65 – 80

Standard version B+C: Bottom plate with elastomer inlay, B: Bottom plate with air cushion. The technical data are comparative values and can vary depending on application. Further data on demand. Subject to technical modification.

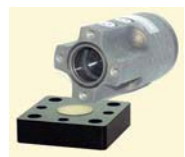

NTP B+C

Type	A [mm]	B [mm]	C [mm]	ØD [mm]	E [mm]	F [mm]	G [mm]	H [mm]	K [mm]	ØL [mm]	N [mm]	Weight [kg]
NTP 25	90	60	46	6,5	36	14,5	G 1/8	15	8	51	G 1/8	0,61
NTP 32	140	75	51	11	48	32	G 1/4	20	10	70	G 1/4	1,47
NTP 48	194	100	78	13	60	51	G 3/8	25	15	95	G 3/8	3,95



aligning of layers

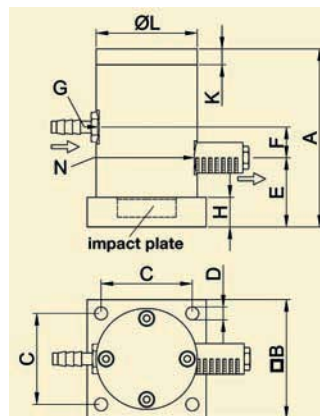

NTP 25 B+C

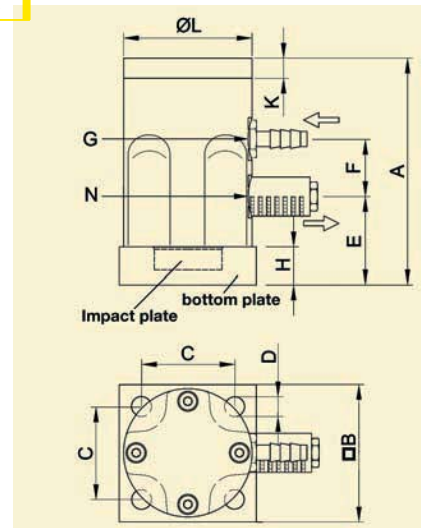

NTP 32 B+C and NTP 48 B+C

Applications

The pneumatic piston vibrators series NTP are especially suitable for knocking off material adhering to container walls in funnels, containers, silos and hoppers. They can be used as drives for vibrating tables and chutes and as assistance for emptying containers. Special features of NTP vibrators are: impacts like a rubber hammer or vibration with high peak acceleration.

Design and functioning principle

The vibration (linear) is produced by a freely vibrating differential pressure piston. In the standard version B+C the piston is knocking against an elastomer impact plate and works like a rubber hammer. In the version B without impact plate the piston works against an air cushion (noise reduced). Hard knocking versions available. The frequency can be adjusted by varying the pressure of the air supply and the amplitude by throttling the exhaust.

For operation a control valve is required (not included in scope of delivery). Lubrication-free operation is possible in compliance with the recommendations of Netter.

ATEX compliant linear vibrators of the NTP series and units with stainless steel housing are available.

Permissible operating conditions

Drive medium:

Compressed air or nitrogen (Filter ≤ 5 µm), preferably with oil mist

Operating pressure:

2 bar to 6 bar

Ambient temperature:

5°C to 60°C

NetterVibration offers the accessories required for the mounting, installation, control and monitoring of vibrators and impactors.

Netter provides solutions.

Consult our experienced application technicians.

Netter GmbH

Germany

Fritz-Ullmann-Str. 9
55252 Mainz-Kastel
Tel. +49 6134 2901-0

Poland

Al. W. Korfatego 195/17
40-153 Katowice
Tel. +48 32 2050947

Switzerland

Erlenweg 4
4310 Rheinfelden
Tel. +41 61 8316200

Spain

Errota Kalea 8
20150 Villabona-Guipúzcoa
Tel. +34 943 694 994

www.NetterVibration.com
info@NetterVibration.com

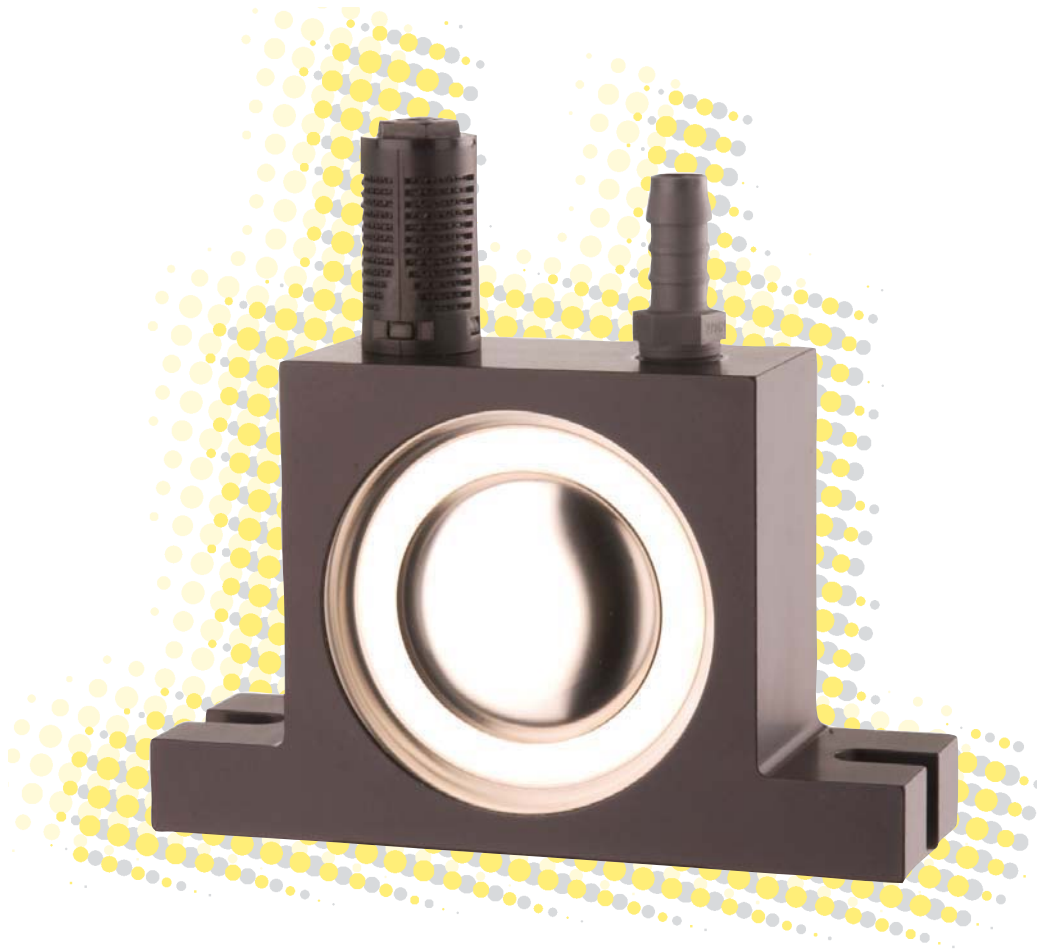

18



Netter Pneumatic Ball Vibrators Series NCB

- Rotary vibration
- Nominal frequency from 7.220 min⁻¹ to 42.340 min⁻¹
- Centrifugal force from 222 N to 4.866 N
- Frequency continuously adjustable via air pressure
- Suitable for temperatures up to 200°C



NCB 1



NCB 10

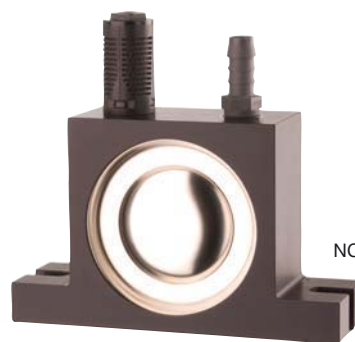

NCB 50



Netter Pneumatic Ball Vibrators Series NCB

Type	Working moment [cmkg]	Nominal frequency [min ⁻¹]			Centrifugal force [N]			Air consumption [l/min] 2 bar - 6 bar	Noise level* [dB(A)] 2 bar - 6 bar
		2 bar	4 bar	6 bar	2 bar	4 bar	6 bar		
NCB 1	0,005	28.460	37.060	42.340	222	377	491	38 - 112	71 - 79
NCB 2	0,009	22.880	31.160	37.540	258	479	696	38 - 115	74 - 79
NCB 3	0,029	17.100	21.600	24.360	465	742	947	81 - 219	74 - 82
NCB 5	0,046	15.220	19.180	22.480	587	933	1.277	77 - 217	78 - 85
NCB 10	0,131	11.320	14.380	16.380	921	1.486	1.928	226 - 463	82 - 89
NCB 20	0,211	10.560	13.780	15.420	1.298	2.198	2.753	222 - 468	78 - 86
NCB 50	0,522	7.220	9.940	11.220	1.492	2.828	3.603	312 - 733	80 - 86
NCB 70	0,808	7.220	8.820	10.480	2.310	3.446	4.866	310 - 728	75 - 84

*Specific silencer to reduce the noise level available.

Type	A [mm]	B [mm]	C [mm]	D [mm]	E [mm]	F	G* [mm]	H* [mm]	K [mm]	Weight [kg]
NCB 1	50	18	86	68	7	G 1/8	40	7	12	0,12
NCB 2	50	18	86	68	7	G 1/8	40	7	12	0,13
NCB 3	65	26	113	90	9	G 1/4	50	9	16	0,29
NCB 5	65	26	113	90	9	G 1/4	50	9	16	0,32
NCB 10	80	37	128	104	9	G 1/4	60	10	16	0,60
NCB 20	80	37	128	104	9	G 1/4	60	10	16	0,70
NCB 50	100	50	160	130	11	G 3/8	80	12	20	1,30
NCB 70	100	50	160	130	11	G 3/8	80	12	20	1,50

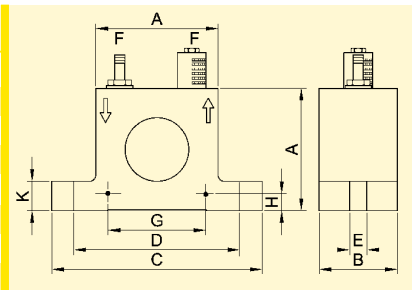

*Dimensions for horizontal mounting, bore ØE



Sorting and aligning



Emptying without bridging

Applications

Series NCB pneumatic ball vibrators can be used wherever bulk materials need to be moved.

They serve in the emptying of bunkers, for preventing bridging, rat-holing and adhesion. When used to drive chutes, sieves and vibrating tables, they ensure that the material flow is maintained.

The special feature is the simple construction.

Construction and Working Principle

The rotary vibration is created by the high centrifugal force produced by a circulating steel ball, which runs on hardened, polished steel races.

The frequency, and hence the centrifugal force, can be continuously regulated via the operating pressure.

Series NCB ball vibrators can be operated using lubrication-free compressed air.

A multi-directional valve is required for operation (not included in the scope of supply).

Permissible Operating Conditions

Drive medium:

Compressed air or nitrogen (filter ≤ 5 µm), preferably with oil mist

Operating pressure:

2 bar to 6 bar

Ambient temperature:

-20°C to +120°C

HT version up to +200°C

NetterVibration offers the accessories required for the mounting, installation, control and monitoring of vibrators and impactors.

Netter provides solutions.

Consult our experienced application technicians.

Netter GmbH

Germany

Fritz-Ullmann-Str. 9
55252 Mainz-Kastel
Tel. +49 6134 2901-0

Poland

Al. W. Korfantego 195/17
40-153 Katowice
Tel. +48 32 2050947

Switzerland

Erlenweg 4
4310 Rheinfelden
Tel. +41 61 8316200

Spain

Errota Kalea 8
20150 Villabona-Guipúzcoa
Tel. +34 943 694 994

www.NetterVibration.com
info@NetterVibration.com



20

Netter Pneumatic Roller Vibrators



Series NCR

- Rotary vibration
- Suitable for aggressive environmental conditions
- High propulsive power
- Nominal frequency from 10.140 min⁻¹ to 34.304 min⁻¹
- Centrifugal force from 878 N to 9.100 N
- Frequency continuously adjustable via air pressure
- Suitable for temperatures up to 200°C





Netter Pneumatic Roller Vibrators Series NCR

Type	Working moment [cmkg]	Nominal frequency [min ⁻¹]			Centrifugal force [N]			Air consumption [l/min]		Noise level [dB(A)]	
		2 bar	4 bar	6 bar	2 bar	4 bar	6 bar	2 bar	6 bar	2 bar	6 bar
NCR 3	0,031	22.699	30.480	34.304	878	1.579	2.000	55	146	74	85
NCR 10	0,102	20.180	24.520	27.760	2.278	3.363	4.311	121	301	74	86
NCR 22	0,224	16.400	20.040	21.780	3.313	4.933	5.828	162	424	77	87
NCR 57	0,572	12.480	14.370	15.465	4.902	6.489	7.520	246	574	74	91
NCR 120	1,200	10.140	11.680	11.760	6.765	8.976	9.100	315	768	86	97

The technical data are comparative values and can vary depending on application. Additional data available upon request.

Type	A [mm]	B [mm]	C [mm]	D [mm]	E [mm]	F	G* [mm]	H* [mm]	K [mm]	Weight [kg]
NCR 3	51	28,5	86	68	7	G 1/8	40	7	12	0,260
NCR 10	67	36	113	90	9	G 1/4	50	9	16	0,579
NCR 22	80	42,5	128	104	9	G 1/4	60	10	16	0,986
NCR 57	100	51	160	130	13	G 3/8	80	12	20	1,875
NCR 120	120	75	194	152	17	G 3/8	100	13	24	4,362

*dimensions for mounting horizontal, bore ØE

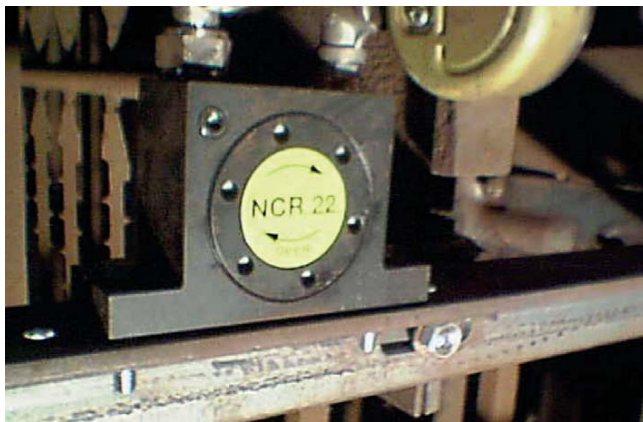
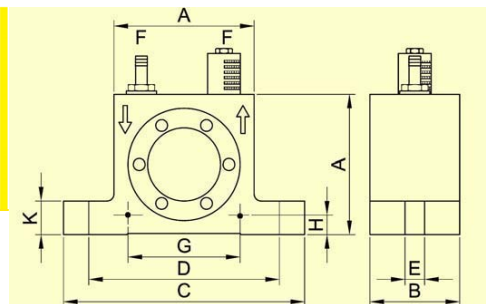

Dusting off filter wires



Emptying silo trailers

Applications

Pneumatic roller vibrators series NCR are particularly suitable for the elimination or reduction of friction.

They can be used for emptying bunkers and preventing adhesion to pipes and plates. Special features of the NCR vibrators are very high frequencies, high centrifugal forces and insusceptible resonance behaviour.

Construction and working principle

The rotary vibration is created by the high centrifugal force of a circulating steel roller, which runs on a steel ring at very high frequency.

The frequency, and hence the centrifugal force, can be continuously regulated via the operating pressure.

Series NCR roller vibrators can be operated using lubrication-free compressed air.

A multi-directional valve is required for operation (not supplied).

Permissible Operating Conditions

Drive medium:

Compressed air or nitrogen (filter ≤ 5µm) preferably with oil mist

Operating pressure:

2 bar to 6 bar

Ambient temperature:

-20°C to 120°C

HT version for temperatures up to 200°C

NetterVibration offers the accessories required for the mounting, installation, control and monitoring of vibrators and impactors.

Netter provides solutions.

Consult our experienced application technicians.

Netter GmbH

Germany

Fritz-Ullmann-Str. 9
55252 Mainz-Kastel
Tel. +49 6134 2901-0

Poland

Al. W. Korfanteo 195/17
40-153 Katowice
Tel. +48 32 2050947

Switzerland

Erlenweg 4
4310 Rheinfelden
Tel. +41 61 8316200

Spain

Errota Kalea 8
20150 Villabona-Guipúzcoa
Tel. +34 943 694 994

www.NetterVibration.com
info@NetterVibration.com



23



Netter Pneumatic Turbine Vibrators Series NCT

- Rotary vibration
- Resistant to aggressive environmental conditions
- Unrestricted, lubrication-free operation
- Nominal frequency from 4.900 min^{-1} to 45.460 min^{-1}
- Centrifugal force from 288 N to 8.659 N
- Frequency continuously adjustable by means of air pressure
- Reduced noise level
- Maintenance-free due to continuously lubricated rolling bearing
- Available in ATEX conform or in stainless steel versions





Netter Pneumatic Turbine Vibrators Series NCT

Type	Working moment [cmkg]	Nominal frequency [min ⁻¹]			Centrifugal force [N]			Air consumption [l/min]		Noise level [dB(A)]	
		2 bar	4 bar	6 bar	2 bar	4 bar	6 bar	2 bar	6 bar	2 bar	6 bar
NCT 1	0,006	29.100	38.820	45.460	288	513	703	19	45	68	83
NCT 2	0,012	21.360	29.520	34.000	311	594	787	20	48	66	81
NCT 3	0,016	26.940	34.900	39.700	637	1.069	1.383	28	75	63	77
NCT 4	0,023	21.740	26.920	30.380	597	915	1.165	31	73	62	76
NCT 4i	0,046	14.020	18.560	21.000	496	869	1.112	31	75	61	73
NCT 5	0,049	22.740	27.840	30.940	1.389	2.082	2.572	93	284	74	90
NCT 10	0,096	16.940	20.680	22.980	1.511	2.251	2.780	92	287	66	78
NCT 10i	0,192	12.200	14.680	16.420	1.567	2.269	2.839	93	286	63	77
NCT 15	0,160	15.740	20.060	22.700	2.174	3.530	4.521	215	461	72	84
NCT 29	0,282	11.920	14.760	16.740	2.197	3.369	4.334	216	461	66	78
NCT 29i	0,564	7.360	10.240	11.780	1.676	3.243	4.291	213	463	63	77
NCT 55	0,545	11.000	13.980	15.760	3.618	5.845	7.426	386	918	77	85
NCT 108	1,081	8.280	10.420	11.720	4.067	6.441	8.152	379	911	73	84
NCT 108i	2,161	4.900	6.860	8.000	2.860	5.590	7.591	392	927	66	77
NCT 126	1,262	6.060	8.280	9.400	2.591	4.760	6.124	653	1.707	71	83
NCT 250	2,502	5.500	7.020	7.800	4.152	6.761	8.348	655	1.710	71	82
NCT 250i	5,000	-	5.100	5.620	-	7.131	8.659	1.222*	1.732	70	74

The technical data are relative values and can vary depending on the application. Additional data available upon request. *at 4 bar

Type	A [mm]	B [mm]	C [mm]	D [mm]	E [mm]	F	G* [mm]	H* [mm]	K [mm]	Weight [kg]
NCT 1	40	27	70	56	6,5	G 1/8	30	5,5	10	0,165
NCT 2	40	27	70	56	6,5	G 1/8	30	5,5	10	0,162
NCT 3	50	32	86	68	7	G 1/8	40	7	12	0,230
NCT 4	50	32	86	68	7	G 1/8	40	7	12	0,240
NCT 4i	50	32	86	68	7	G 1/8	40	7	12	0,250
NCT 5	65	43	113	90	9	G 1/4	50	9	16	0,550
NCT 10	65	43	113	90	9	G 1/4	50	9	16	0,570
NCT 10i	65	43	113	90	9	G 1/4	50	9	16	0,610
NCT 15	80	56	128	104	9	G 1/4	60	10	16	1,045
NCT 29	80	56	128	104	9	G 1/4	60	10	16	1,090
NCT 29i	80	56	128	104	9	G 1/4	60	10	16	1,180
NCT 55	100	73	160	130	13	G 3/8	80	12	20	2,125
NCT 108	100	73	160	130	13	G 3/8	80	12	20	2,250
NCT 108i	100	73	160	130	13	G 3/8	80	12	20	2,500
NCT 126	120	86	194	152	17	G 3/8	100	13	25	3,585
NCT 250	120	86	194	152	17	G 3/8	100	13	25	3,820
NCT 250i	120	86	194	152	17	G 3/8	100	13	25	4,290

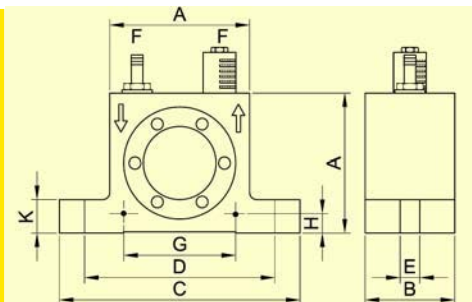

* dimensions for mounting horizontal, bore ØE

Sifting of fine grained products

Applications

Series NCT pneumatic turbine vibrators are particularly suitable for moving bulk materials. They can be used for emptying bunkers, driving chutes, sieves and vibrating tables and for the mechanical stimulation of processes.

Special features of the NCT vibrators are high frequency at low noise level and low air consumption.

Design and functioning principle

The rotary vibration is produced by an eccentrically mounted turbine with integrated unbalance masses. The frequency and therefore the centrifugal force can be continuously regulated via the operating pressure.

A directional control valve is necessary for operation (not supplied).

ATEX conform series NCT turbine vibrators and units with stainless steel housings are available.

Permissible operating conditions

Drive medium:

Compressed air or nitrogen (filter ≤ 5µm), unrestricted, lubrication-free operation

Operating pressure:

2 bar to 6 bar

Ambient temperature:

-20°C to 120°C

NetterVibration offers the accessories required for the mounting, installation, control and monitoring of vibrators and impactors.

Netter provides solutions.

Consult our experienced application technicians.

Netter GmbH

Germany

Fritz-Ullmann-Str. 9
55252 Mainz-Kastel
Tel. +49 6134 2901-0

Poland

Al. W. Korfantego 195/17
40-153 Katowice
Tel. +48 32 2050947

Switzerland

Erlenweg 4
4310 Rheinfelden
Tel. +41 61 8316200

Spain

Errota Kalea 8
20150 Villabona-Guipúzcoa
Tel. +34 943 694 994

www.NetterVibration.com
info@NetterVibration.com



15

Netter Vacuum Fixing Devices for Vibrators Series VAC



- Quick mounting without bolting or welding
- Strong connection due to high vacuum
- Can also be used on curved or uneven surfaces
- Optional air economizer
- ATEX conform and stainless steel versions available
- Customized versions possible



VAC 10 with NCT 4



VAC 15 with PKL 740 ST



VAC 30 with NTS 50/04



Netter Vacuum Fixing Devices for Pneumatic Vibrators Series VAC

Type + Hose set	Air consumption without vibration [l/min]		Weight [kg]	Minimum-Ø for round containers [mm]	Suitable vibrators						
	4 bar	6 bar			NCB	NCR	NCT	NTK	NTS	NTP	PKL
VAC 8 +HG 10 N	40	60	0,95	110	1, 2		1, 2	8 AL, 15 X	120 HF, 120NF*	25**	
VAC 8 +HG 10 S	20	22	1,20					16, 18 AL	180HF, 180NF*		
VAC 10+HG 10 N	40	60	1,05	110	1, 2, 3	3	3, 4	15X, 18AL	180HF, 180NF*	25**	190**
VAC 10+HG 10 S	20	22	1,30						250HF, 250NF*		
VAC 11 +HG 10 N	40	60	1,25	110	3, 5	10	5, 10	18 AL	180HF, 180NF		190**
VAC 11 +HG 10 S	20	22	1,50								
VAC 12+HG 15 N	60	122	2,85	350	10, 20	22	15, 29	25 AL	350HF, 350 NF	25**, 32**, 48**	450**
VAC 12+HG 15 S	29	36	3,20								
VAC 13+HG 15 N	110	170	4,20	850	10, 20	22	15, 29		75/01, 50/01 70/02*	32**	740, 2100
VAC 13+HG 15 S	41	52	4,55								
VAC 15+HG 15 N	110	170	3,40	650	10, 20	22	15, 29	18AL, 25	250HF, 250NF, 350HF, 350NF	32, 48*	740
VAC 15+HG 15 S	41	52	3,75								
VAC 20+HG 15 N	110	170	7,25	850			57		70/02, 54/02, 50/04*	32, 48	2100
VAC 20+HG 15 S	41	52	7,60								
VAC 30+HG 30 N	110	170	11,50	1.500			120	126, 250	50/04, 50/08*	NVG 49, 55, 61 NVG 82, 84*	5000
VAC 30+HG 30 S	49	60	12,00								
VAC 40+HG 40 N	220	340	20,00	1.500					50/08*, 50/10*		

The technical data are comparative values and can vary depending on the application. Additional data available upon request. Subject to technical changes. *Depending on application, please consult **NetterVibration**. **Adapter plate necessary, please include in order!

Type	Model	A [mm]	B [mm]	C [mm]	D [mm]	E [mm]	F [mm]	Type	Model	A [mm]	B [mm]	C [mm]	D [mm]	E [mm]	F [mm]
VAC 8	I	19	8	150	127	30	55	VAC 13	III	70	30	186	241	195	197
VAC 10	I	22	8	200	175	26,5	55	VAC 15	II	56	25	345	290	100	150
VAC 11	I	20	5,5	300	276	26	55	VAC 20	II	70	30	425	370	150	200
VAC 12	I	25	10	300	268	68	100	VAC 30	IV	70	30	396	339	426	370
								VAC 40	V	70	25	426	375,6	425	370

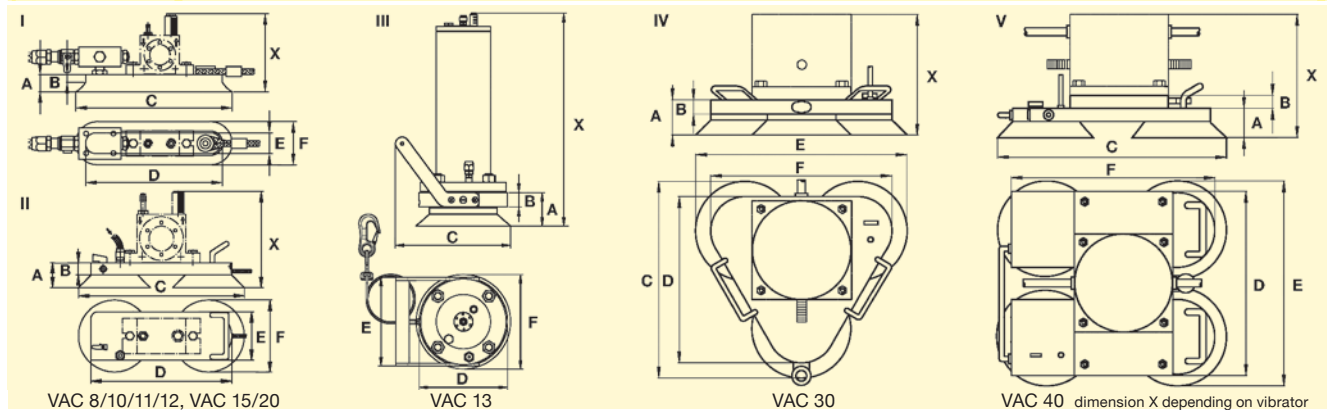

Application

The vacuum fixing devices VAC are designed to allow quick attachment of vibrators to smooth or, under circumstances, uneven and curved surfaces. A special feature of the vacuum fixing is the ease of attachment, which requires no welding or bolting.

Construction and working principle

The appropriate vibrator is screwed to the vacuum fixing and connected to the supply hose leading to the hand valve.

As soon as the vacuum fixing is connected to the compressed air supply, the unit is sucked tightly to the mounting surface, thus ensuring a strong connection between the vibrator and the surface.

The air economizer "S" creates a reduced vacuum, which is sufficient to clamp the vibrator when it is not running and which reduces the air consumption by over 30%.

ATEX conform vacuum fixings series VAC and units with stainless steel plate are available.

When the vibrator starts, the fixing device automatically produces the full vacuum.

Permissible operating conditions

Drive medium:

Compressed air or nitrogen (Filter ≤ 5 µm)

Operating pressure:

2 bar to 6 bar

Ambient temperature:

-10°C to 60°C

NetterVibration offers the accessories required for mounting, installation, control and monitoring of vibrators and impactors.

Netter provides solutions.

Consults our experienced application technicians.

Netter GmbH

Germany

Fritz-Ullmann-Str. 9
55252 Mainz-Kastel
Tel. +49 6134 2901-0

Poland

Al. W. Korfantego 195/17
40-153 Katowice
Tel. +48 32 2050947

Switzerland

Erlenweg 4
4310 Rheinfelden
Tel. +41 61 8316200

Spain

Errota Kalea 8
20150 Villabona-Guipúzcoa
Tel. +34 943 694 994

www.**NetterVibration.com**
info@**NetterVibration.com**



Netter Electric External Vibrators Series NEG/NEA/NED



- Circular vibration
- Nominal frequency from 750 min⁻¹ to 3.600 min⁻¹
- Centrifugal force from 40 N to 217.731 N
- Smooth housing surface
- Stainless steel weight covers
- Ex II 2 GD (ATEX) available
- Protection IP 66-7, Insulation class F
- Stainless steel versions available





NetterVibration

Unbalance Type XL Unbalance Type XM Unbalance Type XS



Netter Electric External Vibrators

Series NEG 3-Phase
Series NEA Single Phase

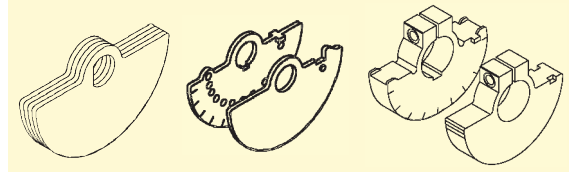

min ⁻¹	Type	Housing		Unbalance		Centrifugal Force		EEx e II **	Power Input				Nominal Current				
		Size	Material	NEG/NEA		NEG/NEA			NEG E	NEG		NEA		NEG		NEA	
				50 Hz	60 Hz	50 Hz	60 Hz			50/60 Hz	50 Hz 400 V	60 Hz 480 V	50 Hz 230 V	60 Hz 115 V	50 Hz 400 V	60 Hz 480 V	50 Hz 230 V
3000 3600	NEA 504*	50	Al	0,08	0,08	40	57	-	-	-	0,024	0,024	-	-	0,13	0,30	
	NEG/NEA 5020*	60	Al	0,39	0,39	192	277	-	0,035	0,035	0,035	0,035	0,15	0,15	0,17	0,42	
	NEG/NEA 5050*			0,91	0,91	450	647	-	0,045	0,045	0,045	0,045	0,16	0,16	0,20	0,46	
	NEG/NEA 5060	100	Al	1,272	1,272	627	904	-	0,12	0,12	0,11	0,11	0,27	0,23	0,56	1,52	
	NEG/NEA 50120	101	Al	2,4	2,4	1.185	1.708	-	0,18	0,18	0,165	0,165	0,35	0,30	0,75	1,52	
	NEG/NEA 50200			4,2	3,0	2.073	2.133										
	NEG/NEA 50300	110	Al	6,02	4,08	2.972	2.900	T3,T4	0,26	0,27	0,28	0,28	0,60	0,50	1,25	2,40	
	NEG/NEA 50550	120	Al	9,99	6,48	4.930	4.606	T3,T4	0,45	0,50	0,5	0,5	0,80	0,75	2,30	4,50	
	NEG/NEA 50770	130	Al	15,59	10,40	7.695	7.392	T3,T4	0,65	0,685	0,7	0,75	1,10	1,00	3,25	7,00	
	NEG 50980	133	Al	19,8	13,2	9.772	9.382	T3	1	1,2	-	-	1,75	1,75	-	-	
NEG 501140	23,0			16,5	11.352	11.727	T4										
1500 1800	NEG/NEA 2530	101	Al	2,4	2,4	296	426	-	0,085	0,095	0,09	-	0,21	0,20	0,43	-	
	NEG/NEA 2570			6,2	4,2	766	747										
	NEG/NEA 25210	110	Al	16,84	11,76	2.078	2.090	T4	0,17	0,17	0,21	-	0,41	0,40	1,00	-	
	NEG/NEA 25420	120	Al	32,64	22,66	4.028	4.027	T3	0,30	0,35	0,24	-	0,60	0,60	1,20	-	
	NEG/NEA 25540			43,80	32,64	5.405	5.800	T4									
	NEG/NEA 25700	130	Al	57,18	41,89	7.056	7.444	T3,T4	0,525	0,665	0,45	-	0,92	0,98	2,50	-	
NEG 25930	133	Al	75,0	52,0	9.254	9.239	T4	0,55	0,68	-	-	0,95	0,95	-	-		
1000 1200	NEG 1630	110	Al	6,02	6,02	331	476	-	0,12	0,135	-	-	0,30	0,30	-	-	
	NEG 1690			16,84	16,84	924	1.330										
	NEG 16190	120	Al	32,64	32,64	1.790	2.578	T4	0,185	0,205	-	-	0,50	0,50	-	-	
	NEG 16310	130	Al	57,18	41,89	3.136	3.309	T4	0,35	0,38	-	-	0,72	0,68	-	-	
	NEG 16410	133	Al	75,0	52,0	4.113	4.106	T4	0,35	0,38	-	-	0,75	0,67	-	-	
	NEG 16500			90,7	66,5	4.974	5.251	-	0,42	0,46	-	-	0,79	0,77	-	-	
750 900	NEG 12100	120	Al	32,64	32,64	1.007	1.450	T3	0,23	0,25	-	-	0,85	0,76	-	-	
	NEG 12180	130	Al	56,8	56,8	1.752	2.523	T3	0,35	0,38	-	-	1,10	1,05	-	-	
	NEG 12230	133	Al	75,0	75,0	2.314	3.332	T4	0,28	0,30	-	-	0,60	0,68	-	-	

*Protection IP 65, **Technical data available upon request

Unbalance Type XLs

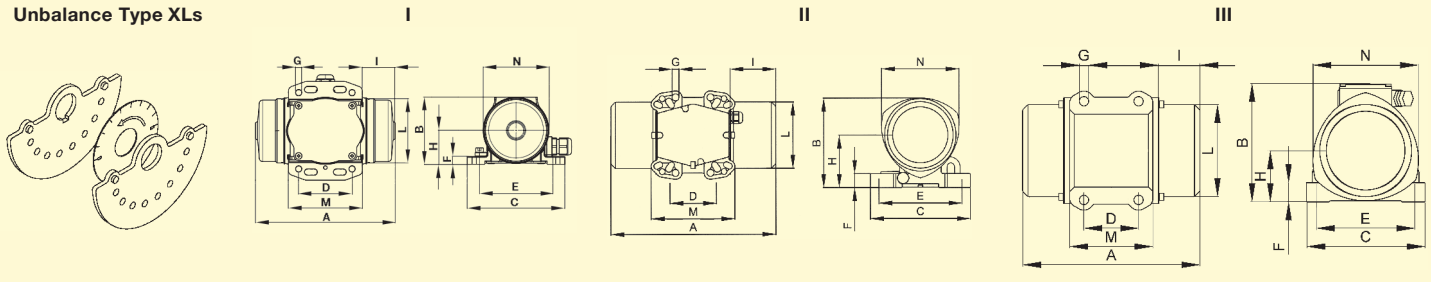

Type	Weight [kg]		Type of Housing	Dimensions [mm]														Unbalance [No. of Unbalance Discs]		
	NEG/NEA			NEG/NEA	NEG/NEA														NEG/NEA	
	50 Hz	60 Hz			A	B	C	Mounting Pattern*			H	I	L	M	N	Type	50/60 Hz			
					D	E	n ₂	F	G											
NEA 504	1,00	1,00	I	111	67	90	25-40	75	4	9	5,5	34	24	63	59	65	XL	8		
NEG/NEA 5020	2,20	2,20	I	157	75	110	60	85	4	9	6,5	38	33	72	83	74	XL	8		
NEG/NEA 5050	2,45	2,45		169			25-40	92					39					18		
NEG/NEA 5060	4,9	4,9	II	197	121	125	60	100	4	20	8,5	71	33	92	86	105	XLs	4		
							62	95												
							65	85												
							70	106												
NEG/NEA 50120	5,9	5,8	II	207	143	165	65	140	4	25	13	86	44	100	156	123	XM	4		
NEG/NEA 50200	6,5	6,3	II	223			62-74	106					9					52	4	
NEG/NEA 50300	10,2	10,0	II	247	173	165	65	140	4	25	13	103	50	124	156	146	XM	4		
							90	125												
NEG/NEA 50550	16,3	16,1	II	283	192	217	100	180	4	30	17	113	63	143	137	168	XM	4		
							105	140			13									
NEG/NEA 50770	22,1	21,6	III	308	212,5	226	100	180	4	35	17	93,5	63	167	162	193	XM	4		
NEG 50980	24,5	23,4	III	314	217	217	100	180	4	35	17	93,5	76	168	152	193	XM	4		
NEG 501140	25,0	24,0																		
NEG/NEA 2530	6,1	5,8	II	207	143	165	65	140	4	25	13	86	44	100	156	123	XM	4		
NEG/NEA 2570	7,3	6,9		243			62-74	106					9					62	4	
NEG/NEA 25210	12,8	11,8	II	307	173	165	65	140	4	25	13	103	80	124	156	146	XS	4		
							90	125												
NEG/NEA 25420	20,7	19,7	II	355	192	217	100	180	4	30	17	113	99	143	137	168	XS	4		
NEG/NEA 25540	22,7	21,7		391			105	140			13		117							
NEG/NEA 25700	29,4	28,4	III	392	212,5	226	100	180	4	35	17	93,5	105	167	162	193	XS	4		
NEG 25930	34,2	32,7	III	442	217	217	100	180	4	35	17	93,5	140	168	152	193	XS	4		
NEG 1630	12,0	10,1	II	247	173	165	65	140	4	25	13	103	50	124	156	146	XM	4		
NEG 1690	12,7	12,7		307			90	125					80							
NEG 16190	20,5	20,5	II	355	192	217	100	180	4	30	17	113	99	143	137	168	XS	4		
							105	140			13									
NEG 16310	28,9	27,9	III	392	212,5	226	100	180	4	35	17	93,5	105	167	162	193	XS	4		
NEG 16410	34,1	33,6	III	442	217	217	100	180	4	35	17	93,5	140	168	152	193	XS	4		
NEG 16500	36,1	35,1																		
NEG 12100	20,5	20,5	II	355	192	217	100	180	4	30	17	113	99	143	137	168	XS	4		
							105	140			13									
NEG 12180	28,0	28,0	III	392	212,5	226	100	180	4	35	17	93,5	105	167	162	193	XS	4		
NEG 12230	34,6	34,6	III	442	217	217	100	180	4	35	17	93,5	140	168	152	193	XS	4		

*Recommended mounting pattern in bold type



NetterVibration



Netter Electric External Vibrators Series NEG 3-Phase

Unbalance Type XLs

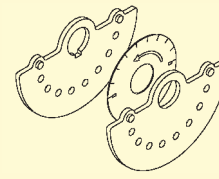

Unbalance Type XS

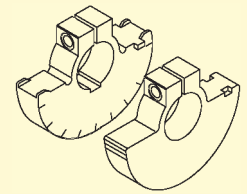

min ⁻¹	Type	Housing Size	Material	Unbalance [cmkg]		Centrifugal Force [N]		EEx e II *	Power Input [kW]		Nominal Current [A]		Weight [kg]		
				50 Hz	60 Hz	50 Hz	60 Hz		50/60 Hz	50 Hz 400 V	60 Hz 480 V	50 Hz 400 V	60 Hz 480 V	50 Hz	60 Hz
3000 3600	NEG 501540	140	AL	30,6	20,4	15.103	14.499	T3, T4	1,4	1,45	2,3	2,0	34,3	32,8	
	NEG 501800			35,8	25,6	17.669	18.195		T3	2,0	2,0	3,3	2,9	35,1	33,6
	NEG 502020	150	GGG	41,0	25,6	20.236	18.195	T3	2,2	2,2	3,5	3,0	49	47	
	NEG 502270			46,0	30,6	22.704	21.748		T3	2,2	2,2	3,5	3,0	50	49
	NEG 503400			65,6	43,7	32.364	31.052		-	3,8	3,8	6,2	5,4	106	102
	NEG 503820	170	GGG	76,5	54,6	37.764	38.827	-	4,0	4,0	6,5	5,6	107	103	
	NEG 506220			126,0	88,6	62.189	62.970		-	5,5	5,5	9,2	8,0	188	181
NEG 508830	190	GGG	179,0	123,8	88.347	87.988	-	10,0	9,3	18,0	13,0	215	210		
1500 1800	NEG 251410	140	AL	112	80,0	13.820	14.215	T3, T4	0,9	1,05	1,45	1,5	44,8	41,8	
	NEG 251800			142,8	97,0	17.620	17.235		-	1,1	1,2	2,0	1,9	49,3	45,3
	NEG 252060	160	AL	163	112,4	20.113	19.971	-	1,35	1,45	2,5	2,3	54	52	
	NEG 252370			192,4	134,8	23.740	23.951		T3, T4	1,6	1,7	3,2	3,0	75	69
	NEG 253050			247,0	171,6	30.477	30.490		-	1,9	2,0	3,8	3,5	82	79
	NEG 253720	170	GGG	301,6	206,7	37.214	36.726	T3, T4	2,2	2,5	3,9	3,9	127	122	
	NEG 254310			349,2	234,7	43.088	41.702		-	2,5	2,8	4,8	4,65	125	120
	NEG 254900	180	GGG	396,8	272,8	48.961	48.472	T3	3,6	3,4	6,0	5,0	174	166	
	NEG 256460	190	GGG	523,8	364,6	64.632	64.783	-	6,0	6,0	10,5	9,0	212	200	
	NEG 258040	195	GGG	652,0	452,0	80.450	80.312	-	7,0	8,0	11,6	11,5	225	210	
	NEG 258260	197	GGG	669,2	492,4	82.573	87.490	-	7,5	8,5	12,2	12,0	317	303	
	NEG 2511210	200	GGG	908,8	633,2	112.137	112.508	-	10,0	10,5	17,5	15,5	433	411	
	NEG 2513850			1.122,8	825,2	138.542	145.981		-	11,0	12,0	20,0	20,0	458	424
	1000 1200	NEG 16810	140	AL	144,2	111,8	7.908	8.829	T3, T4	0,68	0,76	1,4	1,4	46	41
NEG 161130		202,0			142,8	11.078	11.277	-		0,75	0,75	1,7	1,5	57	48
NEG 161420		254,2			187,4	13.940	14.799	-		0,95	1,0	1,8	1,7	65	58
NEG 161610		160	AL	292,8	192,4	16.057	15.194	T3, T4	1,1	1,3	2,2	2,2	80	76	
NEG 162110				385,4	263,6	21.135	20.816		-	1,5	1,77	3,0	2,8	95	83
NEG 162550		170	GGG	464,2	323,0	25.457	25.507	T3	1,96	2,1	4,1	3,75	140	127	
NEG 163030				553,4	400,0	30.348	31.588		-	2,2	2,4	4,5	4,3	156	141
NEG 163820		180	GGG	696,4	467,4	38.191	38.253	T3, T4	2,5	3,0	5,1	5,0	200	182	
NEG 164700				857,0	587,4	46.998	46.387		-	3,2	3,6	6,5	6,0	219	198
NEG 165190		190	GGG	946,4	658,4	51.901	51.994	T3	3,8	4,0	7,0	6,5	247	225	
NEG 165580				1.008,8	706,2	54.560	55.768		-	3,8	3,9	7,0	7,1	240	245
NEG 166270				1.142,8	795,0	62.671	62.781		-	4,3	5,0	8,2	8,1	279	251
NEG 166670		197	GGG	1.216,6	795,8	66.718	62.844	-	5,0	5,9	10,0	9,8	285	257	
NEG 167890		195	GGG	1.439,4	993,4	78.937	78.448	-	7,0	7,5	9,6	13,0	320	282	
NEG 168500				1.550,4	1.077,0	85.024	85.050		-	7,5	8,2	14,0	12,9	326	289
NEG 169510		197	GGG	1.734,6	1.132,8	95.125	89.457	-	7,6	8,0	13,5	12,4	381	340	
NEG 1612060		200	GGG	2.199,2	1.508,6	120.604	119.134	-	9,0	9,5	16,3	15,0	500	445	
NEG 1613890		205	GGG	2.532,4	1.740,0	138.877	137.407	-	10,6	11,3	19,0	18,0	643	605	
NEG 1617000				3.100,0	2.087,8	170.004	164.873		-	13,0	13,7	24,5	23,0	705	656
750 900	NEG 12460	140	AL	144,4	142,2	4.454	6.317	T3	0,4	0,45	1,2	1,2	46	46	
	NEG 12640			202,0	195,6	6.231	8.689			T3, T4	0,5	1,4	1,3	57	57
	NEG 12900	160	AL	292,8	292,8	9.032	13.006	T3	0,95	1,1	2,2	2,2	80	80	
	NEG 121430	170	GGG	464,2	464,2	14.319	20.620	T3	1,5	1,79	4,1	4,2	133	133	
	NEG 122150			696,4	696,4	21.482	30.934		T3	2,0	2,3	5,4	5,2	201	201
	NEG 122640	180	GGG	857,0	857,0	26.436	38.068	-	2,5	3,0	6,0	6,0	217	217	
	NEG 122920			964,4	964,4	29.194	42.839		T3	2,8	3,35	6,5	6,5	242	242
	NEG 123530	190	GGG	1.142,8	1.142,8	35.253	50.764	T3	4,0	4,3	8,2	7,85	267	267	
	NEG 124440			1.439,4	1.439,4	44.402	63.939		-	4,9	5,8	9,9	9,5	320	320
	NEG 127640	197	GGG	2.478,0	2.194,6	76.440	97.485	-	6,8	7,5	13,2	12,0	438	419	
	NEG 128520	200	GGG	2.763,2	2.481,4	85.238	110.225	-	7,6	8,3	14,0	13,5	540	520	
	NEG 1211070	205	GGG	3.589,2	3.100,0	110.718	137.703	-	9,2	9,6	21,0	19,5	702	680	
	NEG 1213160			4.267,4	3.812,8	131.639	169.366		-	10,4	11,2	22,0	20,0	755	711
	NEG 1217670	210	GGG	5.726,6	4.901,6	176.651	217.731	-	12,5	16,2	26,5	28,0	1.015	981	

*Technical data available upon request

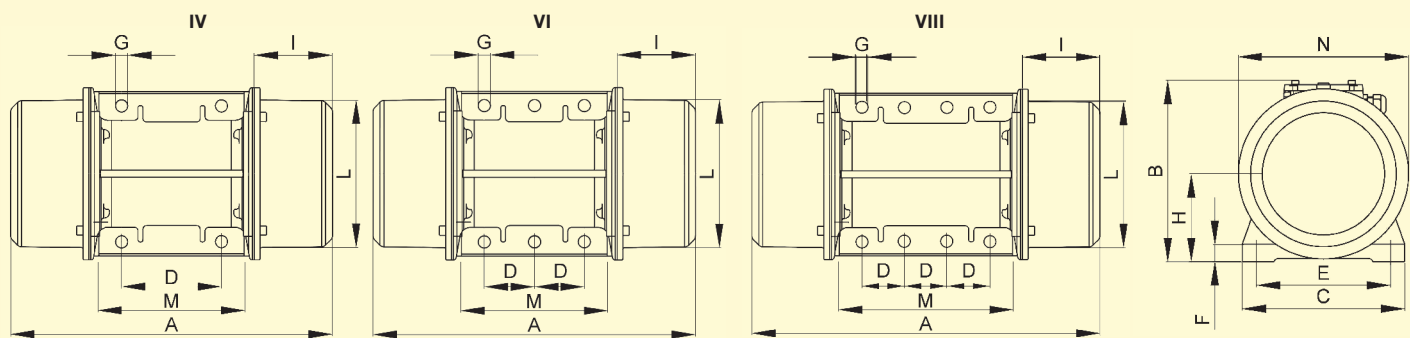

Type	Type of Housing	Dimensions [mm]													Unbalance [No. of Unbalance Discs]	
		NEG	A 50/60 Hz	B	C	D	E	n ₂	F	G	H	I 50/60 Hz	L	M	N	Type
NEG 501540	IV	438	257	230	140	190	4	25	17	124,5	103	201	224	241	XLs	12/8
NEG 501800																14/10
NEG 502020	IV	463	235	230	140	190	4	22	17	104	104	188	248	224	XLs	16/10
NEG 502270																18/12
NEG 503400	IV	590	335	310	155	255	4	30	23,5	160	140	274	302	310	XLs	12/8
NEG 503820																14/10
NEG 506220	IV	670	380	390	200	320	4	32	28	189	155	340	360	384	XS	4
NEG 508830	IV	629	395	392	200	320	4	100	28	192	134,5	358	270	375	XS	4
NEG 251410	IV	438	257	230	140	190	4	25	17	124,5	103	201	224	241	XS	4
NEG 251800		129														
NEG 252060		164														
NEG 252370		130														
NEG 253050	IV	523	283	275	155	225	4	28	22	140	130	231	255	271	XS	4
NEG 253720		168,5														
NEG 253720	IV	588	335	310	155	255	4	30	23,5	160	139	274	302	310	XS	4
NEG 254310		180/139														
NEG 254900	IV	640	369	340	180	280	4	30	26	173	155	301	322	336	XS	4
NEG 256460	IV	670	380	390	200	320	4	32	28	189	155	340	360	384	XS	4
NEG 258040	IV	624	402	392	200	320	4	35	28	199,5	132	358	352	402	XS	4
NEG 258260	VI	862	434,5	460	125	380	6	35	39	215	230	379	392	439	XS	4
NEG 2511210	VI	990	454	530	140	440	6	38	44	230	240	423	510	448	XS	4
NEG 2513850																
NEG 16810	IV	490/438	257	230	140	190	4	25	17	124,5	129/103	201	224	241	XS	4
NEG 161130		560														
NEG 161420		164														
NEG 161610	IV	600/523	283	275	155	225	4	28	22	140	168,5/130	231	255	271	XS	4
NEG 162110		196/168,5														
NEG 162550	IV	670/610	335	310	155	255	4	30	23,5	160	180/150	274	302	310	XS	4
NEG 163030		200														
NEG 163820	IV	742	369	340	180	280	4	30	26	173	206	301	322	336	XS	4
NEG 164700		236														
NEG 165190	IV	772	380	390	200	320	4	32	28	189	206	340	360	384	XS	4
NEG 165580		238														
NEG 166270		245														
NEG 166670		340														
NEG 166670	VI	750	434,5	460	125	380	6	35	39	215	174	379	392	439	XS	4
NEG 167890	IV	854	402	392	200	320	4	35	28	199,5	247	358	352	402	XS	4
NEG 168500																
NEG 169510	VI	862	434,5	460	125	380	6	35	39	215	230	379	392	439	XS	4
NEG 1612060	VI	990	454	530	140	440	6	38	44	230	240	423	510	448	XS	4
NEG 1613890	VIII	960	526	570	140	480	8	41	45	268	200	488	560	516	XS	4
NEG 1617000		240														
NEG 12460	IV	490	257	230	140	190	4	25	17	124,5	129	201	224	241	XS	4
NEG 12640		164														
NEG 12900	IV	600	283	275	155	225	4	28	22	140	168,5	231	255	271	XS	4
NEG 121430	IV	670	335	310	155	255	4	30	23,5	160	180	274	302	310	XS	4
NEG 122150	IV	742	369	340	180	280	4	30	26	173	206	301	322	336	XS	4
NEG 122640		236														
NEG 122920	IV	772	380	390	200	320	4	32	28	189	206	340	360	384	XS	4
NEG 123530		245														
NEG 124440	IV	854	402	392	200	320	4	35	28	199,5	247	358	352	402	XS	4
NEG 127640	VI	1.002	434,5	460	125	380	6	35	39	215	300	379	392	439	XS	4
NEG 128520	VI	1.070	454	530	140	440	6	38	44	230	280	423	510	448	XS	4
NEG 1211070	VIII	1.040	526	570	140	480	8	41	45	268	240	488	560	516	XS	4
NEG 1213160		280														
NEG 1217670	VIII	1.150	607	610	140	520	8	38	45	297	280	542	510	582	XS	4



Netter Electric External Vibrators Series NEG

Special Version with Reduced Duty Time

Applications

Series NEG electric external vibrators are designed for continuous operation with 100% duty time. In addition, special versions with reduced duty times are available. The reduced duty time allows the use of smaller units possible with the same power output.

Design and functioning principle

Special vibrators with larger unbalances can be used for intermittent or short-time operation. Despite smaller unit size they deliver the same centrifugal forces as the next housing size up.

NEG with reduced duty times are built according to the customer's requirements, to enable individual solutions.

Special Version with CC Unbalances

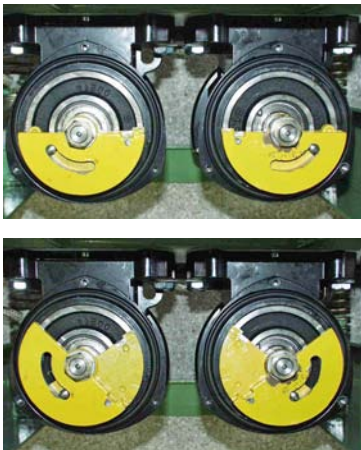

Applications

The special version with CC unbalances are used when two different unbalance settings need to be available during operation.

Design and functioning principle

In order to use the CC unbalances, a suitable electric switching circuit is required so that the NEG can be operated in both directions. When the NEG rotates in one direction it operates with e.g. maximum unbalance (top picture).

When the direction of rotation changes, the outer unbalance disc automatically turns through a specified angle against the inner unbalance disc, creating a reduced unbalance setting (picture below).

The CC unbalances are built according to the customer's requirements and allow a second unbalance setting of 25-100% of the main value.

Special Version NEG S in Stainless Steel



Applications

Series NEG S electric external vibrators can be used wherever the surfaces are subject to particular requirements for chemical resistance. An important feature of the NEG S series is its modular construction. This enables economical production of even the smallest of series in various steel materials. The protection class IP 66 (protection from dust entry and water flooding) allows cleaning with power jets and aggressive cleaning agents.

Design and functioning principle

All internal components of the stainless steel vibrators come from the established NEG series and are thus production proved.

Even the standard version of the NEG S has a surface quality of 6,3 µm and therefore satisfies the requirements for the chemical and pharmaceutical industries. A higher surface quality can easily be provided if required, e.g. for the food industry. Stainless steel housings are generally heavier than the standard housings. The greater mass must therefore be considered in the layout stage.

Static Adjustable Frequency Converter Series NFI/NFU Static Adjustable Frequency Control Series SRF

Applications

The frequency control of the series SRF and the frequency converters of the series NFI and NFU are used for speed regulation of electric vibrators.

Special applications require frequencies which cannot be achieved with normal multipole vibrators at line frequency. These frequency converters are characterized by their robust and straight-forward design.

Design and Functioning Principle

Low-loss power electronics permit the operation at input voltages with high tolerances. The frequency converters generate three-phase voltages with variable frequencies of 0 Hz to 500 Hz, thus making it possible to easily adjust the speed. The permissible temperature range is 0°C to +40°C.

All required parameters such as starting and stopping time, run-up ramp, maximum motor and pulse frequency, slip compensation and U/F characteristic are predefined by **NetterVibration**.

Optionally a brake resistor can be used for time-critical applications or large vibrators which permits a rapid braking / deceleration within a few revolutions after switching off the supply voltage in order to avoid unwanted resonance vibrations.



SRF frequency controls are mounted in a switch cabinet with protection type IP 54.



NFI frequency converters are mounted in an IP 2x housing for installation in a customer existing switch cabinet. The performance data correspond to those of the series SRF.



NFU frequency converters with motor output in the IP 54 housing for wall-mounting are equipped with an on-off switch, direction switch and set point potentiometer.

Type*	Supply Voltage	Max. Motor		Dimensions (W× H× D) [mm]
		Power Input [kW]	Current [A]	
SRF 1-007/4,8	1 ~ 200 ... 240 V 50/60 HZ	0,75	4,8	300 × 400 × 200
SRF 1-011/6,9		1,10	6,9	300 × 400 × 200
SRF 1-022/11		2,20	11,0	400 × 500 × 250
SRF 2-007/2,3	3 ~ 380 ... 415 V 50/60 HZ	0,75	2,3	400 × 500 × 250
SRF 2-015/4,1		1,50	4,1	
SRF 2-022/5,5		2,20	5,5	
SRF 2-040/9,5		4,00	9,5	
SRF 2-055/14,3		5,50	14,3	600 × 600 × 300
SRF 2-075/17		7,50	17,0	
SRF 2-110/27,7		11,00	27,7	
SRF 2-150/33	15,00	33,0		

* Technical data apply also to NFI

Type	Supply Voltage	Max. Motor-Current		Dimensions (W× H× D) [mm]
		Power Input [kW]	Current [A]	
NFU 1-004/3,3	1 ~ 200 ... 240 V 50/60 HZ	0,4	3,3	210 × 240 × 163
NFU 1-007/4,8		0,75	4,8	215 × 297 × 192
NFU 1-011/6,9		1,1	6,9	
NFU 1-015/8		1,5	8,0	
NFU 1-022/11		2,2	11,0	230 × 340 × 208
NFU 2-004/1,5	3 ~ 380 ... 415 V 50/60 HZ	0,4	1,5	215 × 297 × 192
NFU 2-007/2,3		0,75	2,3	
NFU 2-011/3		1,1	3,0	
NFU 2-015/4,1		1,5	4,1	230 × 340 × 208
NFU 2-022/5,5		2,2	5,5	
NFU 2-040/9,5		4,0	9,5	

Netter Braking Devices Series BZ



Type	Supply Voltage	Max. Nominal Power [kW]	Dimensions (W x H x D) [mm]
BZ 30	1 ~ 230 V /	5 / 5,5	55 × 68 × 110
BZ 70	3 – 400 V	10 / 11	158 × 185 × 110
BZ 200	50/60 Hz	26 / 28	145 × 270 × 180

The max. nominal power serves only as a guide for selection. Please consult us, we will help you with your layout!

Applications

Series BZ braking devices are used to bring the running NEG to a standstill as quickly as possible.

It is often necessary to be able to switch off vibrating tables and conveyors without them running on, in order to avoid the symptoms of resonance.

A special feature of these devices is a very high braking efficiency with compact unit size.

Design and functioning principle

Upon activation of the brake the load-resistant power electronics changes the direction of the electric rotational field, thus bringing the NEG to an immediate standstill. The momentarily high braking currents are easily tolerated by the NEG. The permissible temperature range lies between 0°C and +40°C.

These braking devices are only suitable for constant mains frequencies of 50 Hz or 60 Hz. Operation together with a frequency converter is not permitted.



Netter Electric External Vibrators Series NEG

Formulas

Unbalance	$M = s \times m$	Centrifugal force	$F = a_{(g)} \times m \times 9,81$
Acceleration	$a_{(g)} = s \times \left(\frac{n}{1000}\right)^2 \times 5,59$	Centrifugal force	$F = M \times \left(\frac{n}{1000}\right)^2 \times 54,84$

Symbols and Units

s	Amplitude	cm	n	Frequency	min ⁻¹
m	Weight with vibrator	kg	M	Unbalance	cmkg
F	Centrifugal force	N	a _(g)	Acceleration	g

Which Kind of Vibrator for Which Kind of Duty?

Duty	Frequency	Acceleration [a _(g)] Times acceleration due to gravity	Amplitude	Vibration	
				Rotary	Linear
Conveying, dosing	750 – 3000	2 – 5	Large		↔
Sieving	1000 – 1500	3 – 4	Large		↔
Draining	1500 – 3000	3 – 5	Medium		↔
Cleaning, shaking off filters	1500 – 3000	2 – 3	Medium	↻	
Lightening, loosening Emptying bulk material	1500 – 3000	0.15 - 0.2 of weight of material in the conical part of the silo	Medium	↻	
Compacting bulk material	1500 – 6000	2 – 4	Small	↻	↔
Concrete compaction	3000 – 9000	0,8 – 1,5	Very small	↻	↔
Testing components	300 – 6600	0,5 – 5	Adjustable	↻	↔



Conveying



Sieving



Compacting

Applications

Series NEG, NEA or NED electric external vibrators are used whenever, for example, conveyor chutes or sieves need to be driven. In addition, these devices can loosen material blockages and adhesions in silos. When used on concrete forms, the especially even vibration produces high surface quality and compaction of the concrete.

The special feature of the NEG is its maintenance-free operation, even in rough environmental conditions.

Design and functioning principle

Electric external vibrators are unbalance motors, which work according to the short circuit runner principle and, apart from a few significant differences, are very similar to conventional electric motors.

The 3-phase NEG units run at 750, 1000 or 3000 min⁻¹ with a 230/400V, 50 Hz power supply, depending on the number of poles.

The NEA single phase units run at 3000 min⁻¹ with a 230V, 50 Hz power supply. Additional voltages are available.

The direct current NED units run at 3000 min⁻¹ with a 12 or 24 Volt power supply.

Unbalances sitting on each end of the shaft produce an unidirectional sinus-shaped rotation at the frequency of the respective speed of rotation.

All NEG/NEA are also designed for operation at 60 Hz. The speed of rotation then lies at 20% above the values at 50 Hz. The unbalance is adjusted if necessary.

Generously dimensioned rolling bearings guarantee high operational safety. All NEG are suitable for operation with Netter frequency converters, without limitation.

**Netter provides solutions.
Consult our experienced application technicians.**

Netter GmbH

Germany

Fritz-Ullmann-Str. 9
55252 Mainz-Kastel
Tel. +49 6134 2901-0

Poland

Al. W. Korfantego 195/17
40-153 Katowice
Tel. +48 32 2050947

Switzerland

Erlenweg 4
4310 Rheinfelden
Tel. +41 61 8316200

Spain

Errota Kalea 8
20150 Villabona-Guipúzcoa
Tel. +34 943 694 994

www.NetterVibration.com
info@NetterVibration.com



9

Netter Stainless Steel Electric External Vibrators Series NES



- Circular vibration
- Especially resistant to aggressive environmental conditions
- Centrifugal force from 296 N to 42.446 N
- High operational safety
- Tropical insulation by vacuum impregnation
- Protection IP 66
- Nominal frequency from 750 min⁻¹ to 3.600 min⁻¹
- Stainless steel housing
- Ex II 2 D (ATEX) versions available





NetterVibration



Netter Stainless Steel Electric External Vibrators Series NES

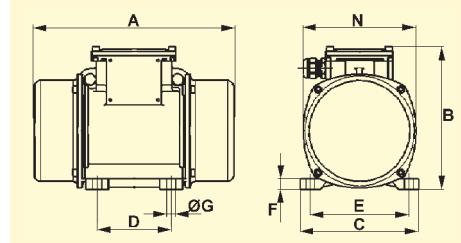

[min ⁻¹]	Type	Working Moment [cmkg]		Centrifugal Force [N]		Power [kW]		Current [A]		Weight [kg]		Dimensions [mm]						
		50 Hz	60 Hz	50 Hz	60 Hz	50 Hz	60 Hz	50 Hz 400 V	60 Hz 480 V	50 Hz	60 Hz	A 50/60 Hz	B	C	D	E	F	G
3000 3600	NES 50120	2,40	2,40	1.185	1.706	0,180	0,180	0,35	0,30	7,80	7,80	209	151	125	62-74	106	10	9
	NES 50210	4,20	3,00	2.073	2.133	0,180	0,180	0,35	0,30	8,20	8,00	225	151	125	62-74	106	10	9
	NES 50300	6,02	4,08	2.972	2.900	0,260	0,270	0,60	0,50	12,50	12,00	255	176	152	90	125	12	13
	NES 50500	9,97	6,48	4.921	4.606	0,450	0,500	0,80	0,75	18,50	17,50	284	200	167	105	140	15	13
	NES 50790	15,59	10,40	7.695	7.392	0,650	0,685	1,10	1,00	25,00	24,00	308	205	205	120	170	17	17
	NES 501090	22,00	14,60	10.858	10.377	1,000	1,200	1,75	1,75	30,00	29,00	354	232	205	120	170	20	17
	NES 501510	30,60	20,40	15.103	14.499	1,400	1,450	2,30	2,00	39,60	38,00	438	245	230	140	190	25	17
	NES 502020	41,00	25,60	20.236	18.195	2,200	2,200	3,50	3,00	48,70	46,30	438	245	230	140	190	25	17
1500 1800	NES 2530	2,40	2,40	296	426	0,085	0,095	0,21	0,20	7,80	7,80	209	151	125	62-74	106	10	9
	NES 2580	6,20	4,20	766	747	0,085	0,095	0,21	0,20	9,00	8,70	225	151	125	62-74	106	10	9
	NES 25100	7,78	6,20	960	1.102	0,085	0,095	0,21	0,20	9,40	9,00	241/225	151	125	62-74	106	10	9
	NES 25210	16,84	11,76	2.078	2.090	0,170	0,170	0,41	0,40	15,80	15,00	295	176	152	90	125	12	13
	NES 25410	32,64	22,66	4.028	4.027	0,300	0,350	0,60	0,60	22,50	21,70	340	200	167	105	140	15	13
	NES 25550	43,80	32,64	5.405	5.800	0,300	0,350	0,60	0,60	23,90	22,50	380	200	167	105	140	15	13
	NES 25720	57,18	41,89	7.056	7.444	0,525	0,665	0,92	0,98	32,00	30,70	378	211	205	120	170	17	17
	NES 251030	83,00	54,20	10.241	9.630	0,550	0,680	0,95	0,95	42,00	37,50	434	232	205	120	170	20	17
	NES 251390	112,20	80,00	13.844	14.215	0,900	1,050	1,45	1,50	53,00	50,00	442	245	230	140	190	25	17
	NES 251760	143,00	97,00	17.645	17.235	1,100	1,200	2,00	1,90	58,50	54,50	490	245	230	140	190	25	17
	NES 252020	163,40	112,20	20.162	19.936	1,350	1,450	2,50	2,30	70,00	68,00	560	245	230	140	190	25	17
	NES 252380	192,40	134,80	23.740	23.951	1,600	1,700	3,20	3,00	82,00	76,00	525	285	275	155	225	30	22
	NES 253050	247,00	171,60	30.477	30.490	1,900	2,000	3,80	3,50	92,00	89,00	601	285	275	155	255	30	22
	NES 253770	305,20	206,80	37.659	36.745	2,200	2,500	3,90	3,90	115,00	110,00	589	323	310	155	255	35	23,5
NES 244250	344,00	234,60	42.446	41.684	2,500	2,800	4,80	4,65	122,00	117,00	589	323	310	155	255	35	23,5	
1000 1200	NES 1630	6,02	6,02	331	476	0,120	0,135	0,30	0,30	12,50	12,50	255	176	152	90	125	12	13
	NES 16100	16,84	16,84	924	1.330	0,120	0,135	0,30	0,30	15,80	15,80	295	176	152	90	125	12	13
	NES 16190	32,64	32,64	1.790	2.578	0,185	0,205	0,50	0,50	22,50	22,50	340	200	167	105	140	15	13
	NES 16320	57,18	41,89	3.136	3.309	0,350	0,380	0,72	0,68	32,00	30,70	378	211	205	120	170	17	17
	NES 16500	91,40	91,40	5.012	7.218	0,350	0,380	0,75	0,68	43,50	43,50	434	232	205	120	170	20	17
	NES 16800	144,60	112,20	7.930	8.860	0,680	0,760	1,40	1,35	54,00	52,60	490/442	245	230	140	190	25	17
	NES 161110	202,40	143,00	11.100	11.293	0,750	0,750	1,65	1,50	67,00	59,50	560/490	245	230	140	190	25	17
	NES 161400	254,80	180,80	13.973	14.278	0,950	1,000	2,10	2,00	78,00	71,00	560	245	230	140	190	25	17
	NES 161610	292,80	192,40	16.057	15.194	1,100	1,300	2,20	2,20	94,00	83,00	601/525	285	275	155	225	30	22
	NES 162120	385,40	263,60	21.135	20.816	1,500	1,700	3,00	2,90	105,00	93,00	601	285	275	155	225	30	22
750 900	NES 162550	465,20	341,20	25.512	26.944	1,960	2,100	4,10	3,75	130,00	116,00	657/589	323	310	155	255	35	23,5
	NES 162950	538,00	388,00	29.504	30.640	2,200	2,400	4,50	4,30	145,00	130,00	705	323	310	155	255	35	23,5
	NES 12100	32,64	32,64	1.007	1.450	0,230	0,250	0,85	0,76	22,50	22,50	340	200	167	105	140	15	13
	NES 12180	56,80	56,80	1.752	2.523	0,350	0,380	1,10	1,05	32,00	32,00	378	211	205	120	170	17	17

Applications

The stainless steel electric vibrators of the NES series are used mainly in the chemical, pharmaceutical and food industries. They serve as drives for conveyor troughs, sieves and discharge devices.

The stainless steel surfaces of the vibrators are especially resistant to chemically corrosive environmental conditions and can be thoroughly cleaned manually and by machine with powerful cleaning agents.

Construction and Working Principle

Stainless steel electric external vibrators are three-phase current asynchronous motors with adjustable unbalances at both ends of the shaft. These unbalances generate an undirected sinusoidal vibration with the frequency of the corresponding rotation speed.

The extremely load-resistant roller bearings guarantee a long working life. All NES are suitable for operation with Netter frequency and voltage converters.

NetterVibration has a worldwide network of experienced application engineers and field representatives. We would be pleased to offer advice on site and to help optimise your applications using vibration technology.

NetterVibration offers the accessories required for the mounting, installation, control and monitoring of vibrators and impactors.

Netter provides solutions. Consult our experienced application technicians.

Netter GmbH

Germany
Fritz-Ullmann-Str. 9
55252 Mainz-Kastel
Tel. +49 6134 2901-0

Poland
Al. W. Korfantego 195/17
40-153 Katowice
Tel. +48 32 2050947

Switzerland
Erlenweg 4
4310 Rheinfelden
Tel. +41 61 8316200

Spain
Errota Kalea 8
20150 Villabona-Guipúzcoa
Tel. +34 943 694 994

www.NetterVibration.com
info@NetterVibration.com

11/2014 Subject to change without notice



36

Netter Static Adjustable Frequency Controls Series SRF / NFI / NFU

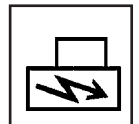

- Infinitely adjustable speed control of electric external and internal vibrators
- Parallel connection of multiple vibrators
- Simple and robust design
- Clearly arranged menu navigation
- Special versions according to customer





NetterVibration



Netter Static Adjustable Frequency Controls Series SRF



Type	Supply Voltage	Max. Motor-		Dimensions (W x H x D) [mm]
		Power Input [kW]	Current [A]	
SRF 1-007/4,8	1~ 200..240V 50/60Hz	0,75	4,8	300 x 400 x 200
SRF 1-011/6,9		1,10	6,9	
SRF 1-022/11		2,20	11,0	
SRF 2-007/2,3	3~ 380..415V 50/60Hz	0,75	2,3	400 x 500 x 250
SRF 2-015/4,1		1,50	4,1	
SRF 2-022/5,5		2,20	5,5	
SRF 2-040/9,5		4,00	9,5	
SRF 2-055/14,3		5,50	14,3	
SRF 2-075/17		7,50	17,0	
SRF 2-110/27,7		11,00	27,7	
SRF 2-150/33	15,00	33,0	600 x 600 x 300	



Switch Cabinet

As a standard, the frequency control systems of the series SRF are mounted in switch cabinets. These switch cabinets are suitable for wall mounting and provide protection against dust and splash water (Protection type IP54). Netter SRF are also available as switch cabinet with socket, with frame and as desk version.

The standard color is light grey. (RAL 7035), other colors or a stainless steel enclosure are available. The motor outputs are connected to a terminal strip or, if requested by the customer, the housing of the switch cabinet is provided with plug connections.

The dimensions of the switch cabinet depend on the size of the frequency converter.

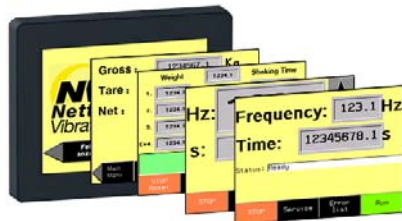

Operation

As a standard, the SRF can be operated and controlled using a 3.5" color touch panel.

The vibration process can be started and stopped by this panel. By buttons or a keyboard the operator can enter the desired frequency and shaking time, readable on large displays. As languages G/E/F can be selected.

The CC unbalance function (big/small working moment) and a control group for two vibrating tables are stored in the program and can be activated if required. Error messages and alarms are displayed in separate windows which simplifies maintenance and service. Depending on the customer's requests, the size of the touch panel and the program of the SRF can be adjusted to suit the requirements on site.

Configuration

If requested, **NetterVibration** can configure additional inputs and outputs on the SRF, therewith safety devices or external operating units can be connected

to the SRF. An optional mini control system allows complex monitoring and control tasks.

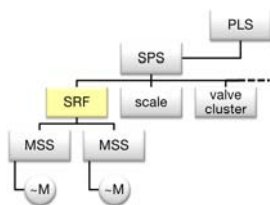

Bus Communication

Netter SRF can be used for all kinds of communication configurations in industrial plants.

The communication via Modbus, CANopen and other bus systems is possible after consultation with **NetterVibration**.

When the SRF is integrated into an existing production process, it communicates with the central process control system.



Avoiding Uncontrolled Resonances

The integrated braking function in the frequency converter helps to prevent uncontrolled oscillation when decelerating the vibrators. This might have a negative effect on the vibration result.

Depending on the application and for the control of multipole vibrators with high working moments we recommend the use of separate brake resistors.

Netter Static Adjustable Frequency Converter Series NFI



Type	Supply Voltage	Max. Motor-		Dimensions (W x H x D) [mm]
		Power Input [kW]	Current [A]	
NFI 1-007/4,8	1~ 200..240V 50/60Hz	0,75	4,8	72 x 145 x 142
NFI 1-011/6,9		1,10	6,9	107 x 143 x 132
NFI 1-022/11		2,20	11,0	142 x 184 x 152
NFI 2-007/2,3	3~ 380..415V 50/60Hz	0,75	2,3	107 x 143 x 132
NFI 2-015/4,1		1,50	4,1	142 x 184 x 152
NFI 2-022/5,5		2,20	5,5	
NFI 2-040/9,5		4,00	9,5	
NFI 2-055/14,3		5,50	14,3	180 x 210 x 172
NFI 2-075/17		7,50	17,0	
NFI 2-110/27,7		11,00	27,7	
NFI 2-150/33		15,00	33,0	245 x 295 x 192

NFI frequency converters are mounted in an IP 2x housing for installation in a customer's existing switch cabinet. The performance data correspond to those of the series SRF.

Netter Static Adjustable Frequency Converter Series NFU



Type	Supply Voltage	Max. Motor-		Dimensions (W x H x D) [mm]
		Power Input [kW]	Current [A]	
NFU 1-004/3,3	1~ 200..240V 50/60Hz	0,4	3,3	210 x 240 x 163
NFU 1-007/4,8		0,75	4,8	
NFU 1-011/6,9		1,1	6,9	215 x 297 x 192
NFU 1-015/8		1,5	8,0	
NFU 1-022/11		2,2	11,0	230 x 340 x 208
NFU 2-004/1,5	3~ 380..415V 50/60Hz	0,4	1,5	215 x 297 x 192
NFU 2-007/2,3		0,75	2,3	
NFU 2-011/3		1,1	3,0	
NFU 2-015/4,1		1,5	4,1	230 x 340 x 208
NFU 2-022/5,5		2,2	5,5	
NFU 2-040/9,5		4,0	9,5	

Netter frequency converters series NFU with motor output in the IP 54 housing for wall-mounting are equipped with an on-off switch, direction switch and potentiometer for frequency setting.

A display at the device shows the output frequency of the converter. The NFU can also communicate with other devices via Modbus or CANopen. The NFU offers the possibility to connect one vibrator. In case two or more vibrators are required, it is necessary to connect an external motor terminal box as well as a motor protection relay.

Optionally, a brake resistor can be mounted and connected to prevent uncontrolled vibrations in critical applications if required. The NFU is pre-adjusted and ready for installation.

Design

Depending on the application a reserve should be calculated when designing the frequency converter, as bigger vibrators have a higher starting current. If multi-pole vibrators (4 or 6-pole) are required, we recommend using Netter frequency converters with three-phase supply.



NetterVibration

Netter Static Adjustable Frequency Controls Special version of the series SRF

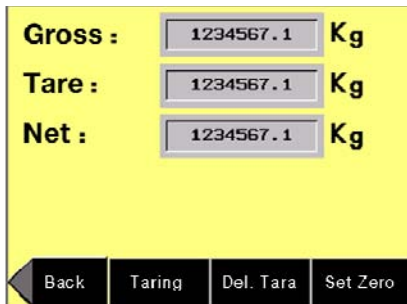

Integrated Weighing Mechanism

If required, **NetterVibration** offers the SRF with integrated weighing mechanism. It is possible to simultaneously compact and weigh bulk material by mounting weighing cells at the vibration table. The current weight is shown on the touch panel of the SRF. Also weight-dependent shaking applications are possible.

Pre-adjusted and ready for Installation

All required parameters, such as starting and stopping time, run-up ramp, maximum motor and pulse frequency, slip compensation and U/K characteristic will be pre-adjusted and tested depending on the application by **NetterVibration** before delivery.

After installation and connection at the customers' site the SRF is ready for operation.



Explosion-proof Control Systems

In dialogue with the user **NetterVibration** implements control systems which fulfil all requirements of the ATEX directive. These control systems comply with the Equipment Group II. Depending on the version it can be used in hazardous areas of the zones 1, 2, 21 or 22.



SRF with vibrating table



Integrated weighing system



SRF and vibrating table made of stainless steel



Vibrating table with roller track

Applications

The frequency control of the series SRF and the frequency converters of the series NFI and NFU are used for speed regulation of electric vibrators. Special applications require frequencies which cannot be achieved with normal vibrators at line frequency. These frequency converters are characterized by their simple and robust design.

Design and Functioning Principle

Low-loss power electronics allows the operation at input voltages with high tolerances. The frequency converters generate three-phase voltages with variable frequencies of 0 Hz to 500 Hz, what makes it possible to easily adjust the speed. The permissible temperature range is 0°C to +40°C.

All required parameters such as starting and stopping time, run-up ramp, maximum motor and pulse frequency, slip compensation and U/F characteristic are defined by **NetterVibration**.

Optionally a brake resistor can be used for time-critical applications. The brake resistor permits a fast braking within a few revolutions in order to avoid unwanted resonance vibrations.

NetterVibration offers the accessories required for the mounting, installation, control and monitoring of vibrators and impactors.

Netter provides solutions. Consult our experienced application technicians.

Netter GmbH

Germany
Fritz-Ullmann-Str. 9
55252 Mainz-Kastel
Tel. +49 6134 2901-0

Poland
Al. W. Korfanteo 195/17
40-153 Katowice
Tel. +48 32 2050947

Switzerland
Erlenweg 4
4310 Rheinfelden
Tel. +41 61 8316200

Spain
Errota Kalea 8
20150 Villabona-Guipúzcoa
Tel. +34 943 694 994

www.**NetterVibration.com**
info@**NetterVibration.com**

11/2014 Subject to change without notice

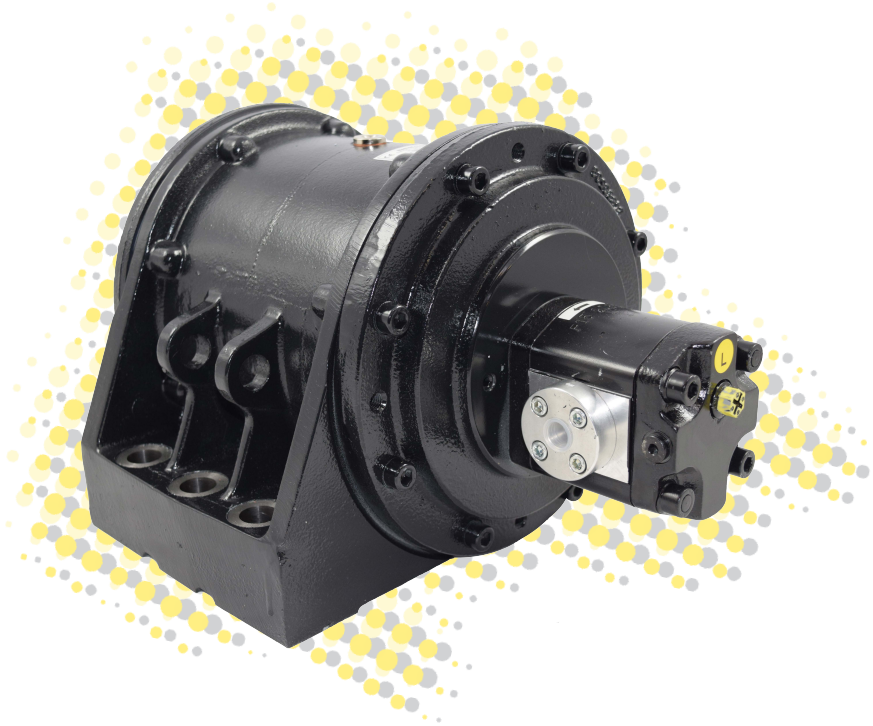

32

Netter Hydraulic External Vibrators Series NHG L



- Rotary vibration
- Nominal frequency from 3.000 min⁻¹ to 7.000 min⁻¹
- Centrifugal force from 4.070 N to 61.206 N
- Frequency continuously variable via volume flow rate



NHG 500 L



NHG 3000 L



NHG 6000 L



Netter Hydraulic External Vibrators Series NHG L

Type	Unbalance [cmkg]	Frequency [U/min]	Normal Operation 100%		Frequency [U/min]	Short operation ≤ 60%		Weight [kg]
			Centrifugal Force [N]	Oil requirement [l/min]		Centrifugal Force [N]	Oil Requirement [l/min]	
NHG 500 L	2,06	6.000	4.070	12	7.000	5.550	14	6,4
NHG 600 R L	0 to 3	6.000	5.922	12	7.000	5.723*	14	8,2
NHG 900 L	6,64	4.000	5.870	8	5.000	9.100	10	7,7
NHG 3000 L	29,18	3.500	19.600	20	4.000	25.600	22	29,0
NHG 6000 L	124,00	3.000	61.206	40	—	—	—	78,0

*) The unbalance must be reset to 2,19 cmkg.

Type	A [mm]	B [mm]	C [mm]	D [mm]	E [mm]	F [mm]	Ø G [mm]	H [mm]	I [mm]	K [mm]	Ø L	M [mm]	Ø P	Ø R
NHG 500 L NHG 600 R L NHG 900 L	194	120	120	160	25	36,5	17	213,5	80	36,5	G1/4	49	G1/4	G3/8
NHG 3000 L	260	195	140	200	30	80	17	310	70	50	M12x1,5	96	G3/8	G3/8
NHG 6000 L	345	260	213	300	58	128,5	22	400	2 x 60	59	M12x1,5	113	G3/8	G3/8

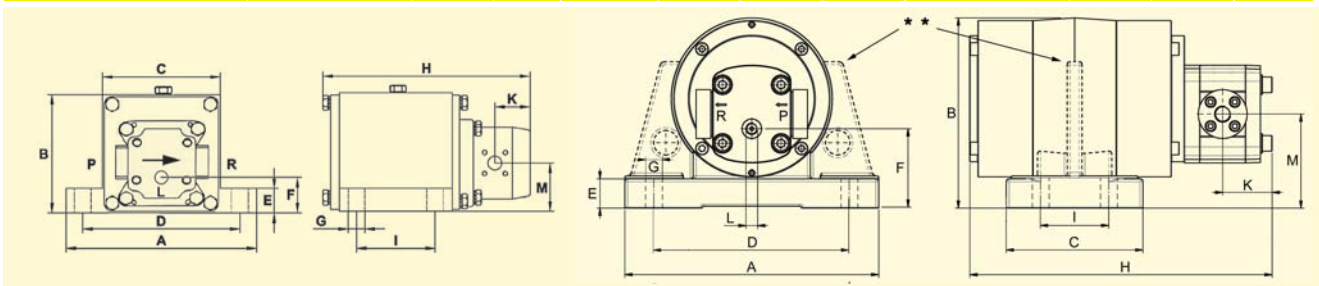

NHG 500 L, NHG 600 R L and NHG 900 L

NHG 3000 L and NHG 6000 L ***) Side strut at NHG 3000 L



NHG 3000 L



Emptying silo vehicles



NHG 900 L

Applications

Series NHG L hydraulic external vibrators are particularly suitable for emptying containers and bulk material hoppers containing adherent bulk materials, for preventing bridging and tubing and for compacting various materials.

A special characteristic is its use for unloading transport vehicles, e.g. trucks, silo buses and ships.

The vibrators are driven via the hydraulic system belonging to the carrier vehicle, and are therefore independent of any external energy supply.

Design and functioning principle

The rotary vibration is created by an unbalance. High rotational speeds result in large centrifugal forces.

The rotational speed, and hence the centrifugal force, can be regulated continuously via the volume flow rate.

NHG 500 L, NHG 900 L and NHG 3000 L and NHG 6000 L have fixed working moments.

The unbalance of the NHG600 RL can be adjusted in steps, from the outside.

Series NHG L hydraulic external vibrators are also available without an overflow oil line connection.

The pressure in the return line must not exceed 2 bar.

Permissible operating conditions:

Drive Medium:

Clean, filtered hydraulic oil DIN 51524/25 or engine oil DIN 51511

Operating pressure:

Pressure side 200 bar max.
Overflow oil line back pressure 2 bar max.

Ambient temperature:

-20°C to 80°C NHG 500 L to NHG 900 L
-20°C to 60°C NHG 3000 L
-20°C to 40°C NHG 6000 L

NetterVibration offers the accessories required for the mounting, installation, control and monitoring of vibrators and impactors.

Netter provides solutions.

Consult our experienced application technicians.

Netter GmbH

Germany

Fritz-Ullmann-Str. 9
55252 Mainz-Kastel
Tel. +49 6134 2901-0

Poland

Al. W. Korfantego 195/17
40-153 Katowice
Tel. +48 32 2050947

Switzerland

Erlenweg 4
4310 Rheinfelden
Tel. +41 61 8316200

Spain

Errota Kalea 8
20150 Villabona-Guipúzcoa
Tel. +34 943 694 994

www.NetterVibration.com
info@NetterVibration.com

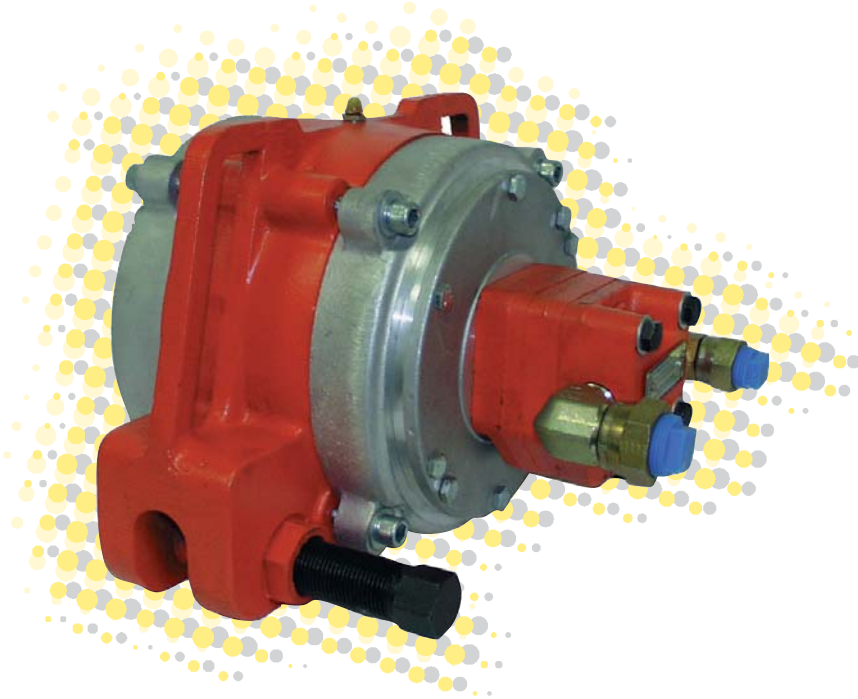

30

Netter Hydraulic External Vibrators Series CC, CV, CCV and DV



- Driven by flanged hydraulic motor
- Nominal frequency from 1.750 min⁻¹ to 5.400 min⁻¹
- Centrifugal force from 7.320 N to 49.210 N
- Frequency continuously adjustable by hydraulic pressure
- High working moment, high amplitude
- Low unit weight combined with high capacity
- Mounting by attachment screw (CCV), bracket (CC) or flange (CV/DV)



CV 2.8



CC 2.8



CCV 6



DV 6



Netter Hydraulic External Vibrators Series CC, CV, CCV and DV

Type	Unbalance adjustment **	Working moment [cmkg]	Starting pressure [bar]	Frequency* [U/min]	Volume flow [l/min]	Centrifugal force [N]	Frequency* [U/min]	Volume flow [l/min]	Centrifugal force [N]	Weight [kg]
CC2.8-5HB CV2.8-5HB CCV 4-5HB DV 4-5HB	1	18,3	13	2.700	15,5	7.320	4.400	26,5	19.430	
	2	18,0	12	2.800	15,9	7.740	4.500	25,7	19.990	17,0
	3	16,9	10	2.800	17,0	7.270	4.600	26,9	19.610	16,5
	4	15,3	9	3.300	18,9	9.140	4.800	27,3	19.330	20,0
	5	12,8	9	3.800	21,6	10.140	5.000	28,8	17.550	19,0
	6	9,8	7	4.000	22,7	8.600	5.400	30,3	15.670	
CCV6-12-8HA DV6-12-8HA	0 - 100 %	28	8	2.750	34,0	11.610	3.500	45,8	18.810	39,0 44,7
CCV6-25-8HA DV6-25-8HA	0 - 100 %	59	9	2.500	30,7	20.220	3.900	43,5	49.210	40,4 46,1
CCV6-50-8HA DV6-50-8HA	0 - 100 %	119	11	1.750	23,5	19.980	2.600	34,1	44.110	44,2 49,9

CC = mounting with bracket NVH
CCV = mounting with attachment screw

DV/CV = mounting with flange screw
5 HB/8 HA = hydraulic motor

* Notice: Hydraulic external vibrators for higher frequency see leaflet series NHG.

**The working moment of series CC, CV, CCV and DV 2.8/4 is adjustable in 6 steps.

Type	A [mm]	B [mm]	C [mm]	D [mm]	E [mm]	F [mm]	G [mm]	H [mm]	Outlet J	Inlet K
CV 2.8	250,8	174,6	249,2	203,2	76,2	87,3	23,8	22,0	3/4"	1/2"
CC 2.8	228,6	181,0	241,3	-	76,2	87,3	-	-	3/4"	1/2"
CCV 4	292,1	209,6	244,5	209,6	23,8	104,8	-	-	3/4"	1/2"
DV 4	304,8	206,4	244,5	4 bores: 63,5 x 266,7	101,6	101,6	22,2	16,5	3/4"	1/2"
CCV 6	368,3	287,3	320,7	285,8	25,4	142,9	-	-	3/4"	1/2"
DV 6	457,2	279,4	320,7	6 bores: 50,8 x 50,8 x 406,4	152,4	141,3	28,6	22,0	3/4"	1/2"

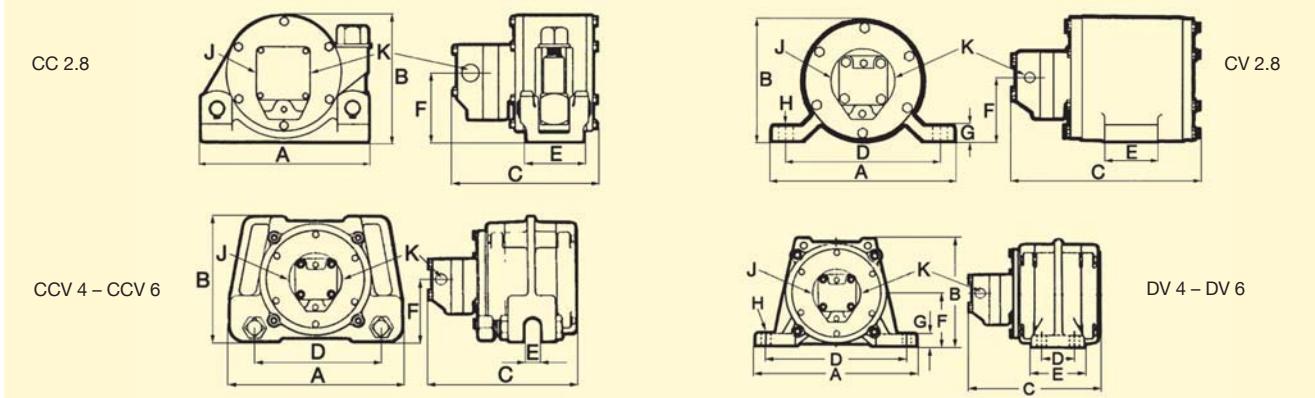

Application

Netter hydraulic external vibrators series CV, CC, CCV and DV are especially suitable to unload rail wagons and bulk hoppers as well as for the sieving and compacting of different materials.

Trucks and tractors which use hydraulic energy for dumping and lifting, are sources of hydraulic power.

A special feature of CC/CCV vibrators is the quick manual repositioning.

Design and functioning principle

The vibration (circular) is produced by unbalance pairs with double bearings.

The frequency and thus the centrifugal force are continuously adjustable by the volume flow. The hydraulic external vibrators generate high amplitudes with low frequencies.

The working moment of series CC, CV, CCV and DV 2.8/4 is adjustable in 6 steps. The working moment of series DV 6-12,

-25 and -50 is continuously adjustable. The only difference between the units is the execution of the housings. The vibrators generate very high forces in proportion to their weight.

Permissible operating conditions

Drive medium:

Hydraulic oil (clean and filtered)
DIN 51524/25 or motor oil DIN 51511

Operating pressure:

Max. 80 bar inlet,
max. 2 bar outlet.

Ambient temperature:

- 20°C to 60°C

NetterVibration offers the accessories required for the mounting, installation, control and monitoring of vibrators and impactors.

Netter provides solutions.

Consult our experienced application technicians.

Netter GmbH

Germany

Fritz-Ullmann-Str. 9
55252 Mainz-Kastel
Tel. +49 6134 2901-0

Poland

Al. W. Korfantego 195/17
40-153 Katowice
Tel. +48 32 2050947

Switzerland

Erlenweg 4
4310 Rheinfelden
Tel. +41 61 8316200

Spain

Errota Kalea 8
20150 Villabona-Guipúzcoa
Tel. +34 943 694 994

www.NetterVibration.com
info@NetterVibration.com



14

Netter Pneumatic External Vibrators Series NVR, NVG, NVT and NQT



- Circular vibration
- Nominal frequency from 8.500 min⁻¹ to 17.000 min⁻¹
- Centrifugal force from 7.130 N to 62.260 N
- Frequency infinitely variable by air pressure
- No bearings
- Easily and quickly removable
- Noise reduced design NQT



NVG 61



NVR 61



NVT with bracket NVH 4



Netter Pneumatic External Vibrators Series NVR, NVG, NVT and NQT

Type		NVR [®] , NVG [®]			NVT [®] , NVG [®]		NVT [®] , NVG [®]			NQT	
		49	55	61	82	113	84	87	105	93	108
Nominal frequency	[min ⁻¹]	17.000	16.500	16.000	9.000	8.500	16.000	15.200	14.500	10.000	10.000
Centrifugal force	[N]	7.130	11.000	14.250	15.320	38.830	27.400	37.500	62.260	18.480	24.788
Unbalance	[cmkg]	0,45	0,74	1,02	3,45	9,80	1,95	2,96	5,40	3,37	4,52
Air consumption	[l/min]	1.000	1.100	1.200	1.600	1.700	1.600	1.600	1.800	1.450	1.550
Weight	[kg] ①	6,6	7,0	7,6	14,9	16,9	14,0	14,4	16,3	-	-
without hose	[kg] ②	7,1	7,3	7,8	19,7	22,6	20,0	20,4	22,4	-	-
Weight with hose	[kg]	-	-	-	-	-	-	-	-	18,6	20,3

NVG with base plate. NVT and NQT with carrying handle on top for bracket NVH 4. NVR without carrying handle for bracket NVH 1. Data obtained on 6 bar.

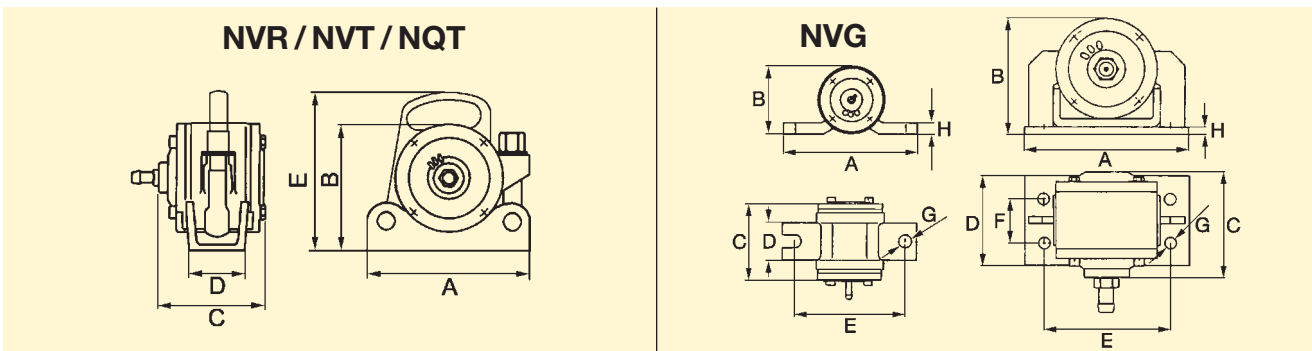

Type	A [mm]	B [mm]	C [mm]	D [mm]	E [mm]	F [mm]	Ø G [mm]	H [mm]
NVG 49, 55, 61	220	111	175	60	180	-	20	20
NVR 49, 55, 61	182	140	175	90	-	-	-	-
NVT 82, 113, 84, 87, 105	240	185	150	83	225	-	-	-
NVG 82, 113, 84, 87, 105	260	187	145	140	200	70	17	12
NQT 93, 108	240	230	240	80	-	-	-	-



Compacting of moulding sand



Tunnel moulds

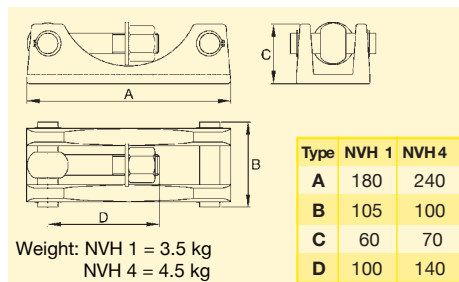

Dimensions of NVH 1 and NVH 4

Application

The pneumatic external vibrators series NQT, NVG, NVR und NVT are especially suitable for compacting, conveying and loosening bulk material.

They are used to compact concrete, empty bins and as drives for conveyors, sieves and vibrating tables.

A special feature is the ruggedness against strong varying loads. There is no danger of overload.

Design and functioning principle

The vibration (circular) is produced by eccentric rotating rotors. The frequency and herewith the centrifugal force are continuously adjustable by the operating pressure. For operation a control valve is required (not included in scope of delivery).

Permissible operating conditions

Drive medium:

Compressed air or nitrogen (Filter ≤ 40 µm), preferably with oil mist.

Operating pressure:

1 bar to 7 bar

Ambient temperature:

-10°C to +60°C

Units for other temperatures are available.

NetterVibration offers the accessories required for the mounting, installation, control and monitoring of vibrators and impactors.

Netter provides solutions.

Consult our experienced application technicians.

Netter GmbH

Germany

Fritz-Ullmann-Str. 9
55252 Mainz-Kastel
Tel. +49 6134 2901-0

Poland

Al. W. Korfantego 195/17
40-153 Katowice
Tel. +48 32 2050947

Switzerland

Erlenweg 4
4310 Rheinfelden
Tel. +41 61 8316200

Spain

Errota Kalea 8
20150 Villabona-Guipúzcoa
Tel. +34 943 694 994

www.NetterVibration.com
info@NetterVibration.com



40

Netter Vibrating Cross Series NKH and NKM



- Compacting of dry refractory mass for induction furnace
- Constant, effective compaction
- Solid in-tension, vibration of the total mould
- Manual or hydraulic tightening according to selected type
- Compacting in a few minutes
- Same vibrator also for bottom



NKM (manual)



NKH (hydraulic)



Netter Vibrating Cross Series NKH and NKM

Type	Mould diameter [mm]	Weight without vibrator [kg]	A [mm]		B [mm]		C [mm]		D [mm]	E [mm]	F [mm]	
			min	max.	min	max.	min	max.			NKH	NKM
NKH, NKM 300	400- 600	33	360	390	312	342	300	330	150	46±1	550	400
NKH, NKM 400	500- 700	37	460	490	412	442	400	430	150	46±1	550	400
NKH, NKM 500	600- 800	40	560	590	512	542	500	530	150	46±1	550	400
NKH, NKM 800	920-1160	72	860	890	812	842	800	830	150	46±1	550	555
NKH, NKM 900	1120-1240	124	1060	1100	917	957	900	940	150	46±1	810	660

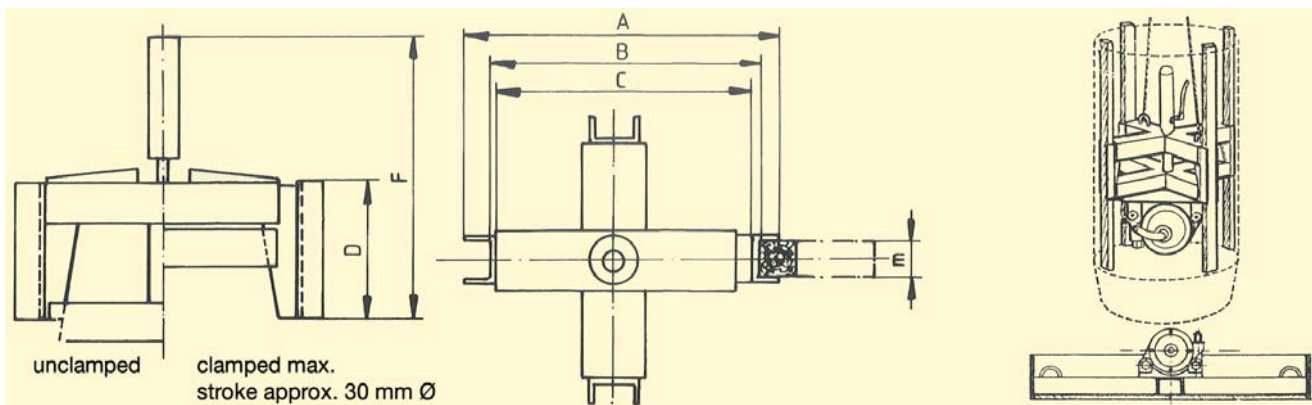

Vibrator	Working moment [cmkg]	Air consumption [l/min]	Weight [kg]	Nominal frequency [min ⁻¹]	Centrifugal force [N]
NVT 105	5,40	1.800	16,3	14.500	62.260



Applications

Netter vibrating crosses of NKH and NKM series are used for compacting dry refractory mass in induction furnaces.

Design and Working Principle

The Netter vibrating cross consists of a cross-shaped clamping fixture and a pneumatic external vibrator of NVT series. The vibrator is attached to the cross by a quick-clamping device of the NVH 4 series.

The cross is tightened either manually by means of a shaft (NKM) or by a hydraulic cylinder (NKH). When tightened, the 4 clamping jaws extend equally.

Hardwood battens, laid between the vibrating cross and the wall of the stamping mould, assure the adjustment of the vibrating cross as well as the constant power transmission. The compaction is caused by the vibrating motion of the complete mould. The bottom can also be compacted by using the same vibrator mounted on a base-plate.

NetterVibration offers the accessories required for the mounting, installation, control and monitoring of vibrators and impactors.

Netter provides solutions. Consult our experienced application technicians.

Netter GmbH

Germany
Fritz-Ullmann-Str. 9
55252 Mainz-Kastel
Tel. +49 6134 2901-0

Poland
Al. W. Korfanteo 195/17
40-153 Katowice
Tel. +48 32 2050947

Switzerland
Erlenweg 4
4310 Rheinfelden
Tel. +41 61 8316200

Spain
Errota Kalea 8
20150 Villabona-Guipúzcoa
Tel. +34 943 694 994

www.NetterVibration.com
info@NetterVibration.com

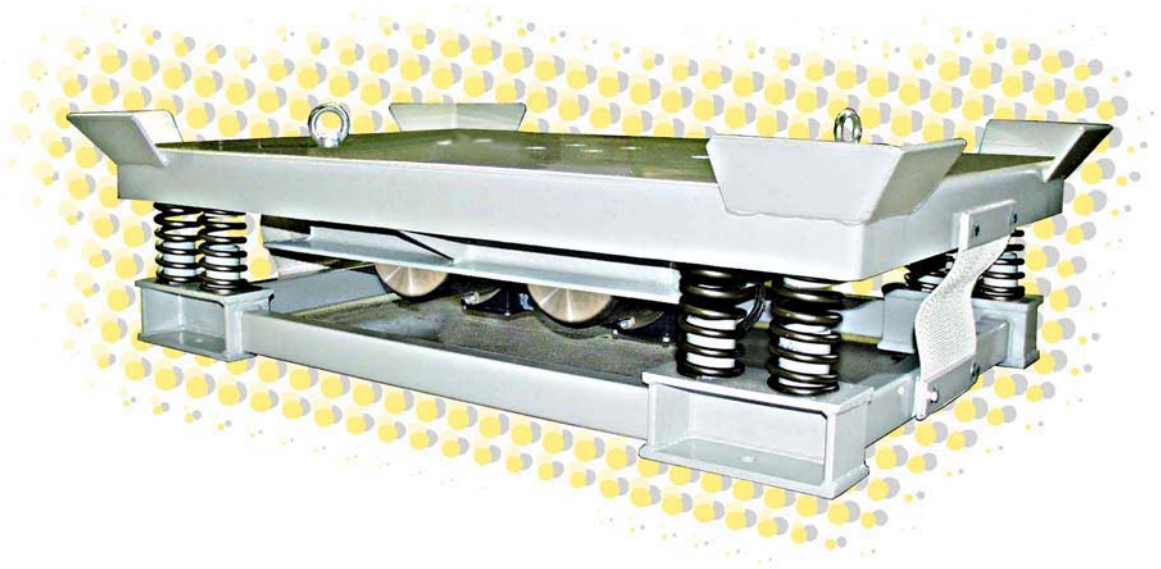

41

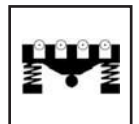

Netter Vibrating Tables Series VT

- Elektric or pneumatic drives
- Variable centrifugal force
- Adjustable vibration amplitude
- Directional or circular rotation
- Optimum vibration insulation
- Low noise
- Low overall height
- Robust versions for continuous operation
- Various controls and accessories
- Movable



VTP 3/3
with NTS 350 NF
pneumatic



VTF 8/8
with 2 NTS 50/08
flat design



VT 7/8
with 2 NEG 50770
electric



Netter Vibrating Tables Series VT

A small extract from our range of vibrating tables

Version	Type	Vibrator	Length [mm]	Width [mm]	Height [mm]	Vibrations	Weight [kg]
Electric	VTE 3/3	NEG 50120	300	300	273	circular	20
	VTE 6/6	2xNEG 2570	600	600	273	vertical directional	41
	VTE 8/12	2xNEG 25930	800	1200	350	vertical directional	290
Pneumatic	VTP 3/3	NTK 18 AL	300	300	350	vertical directional	22
	VTP 5/5	NTS 50/01	500	500	350	vertical directional	31
	VTP 10/10	NTS 50/08	1000	1000	300	vertical directional	185

All sizes: A special feature is the flat construction, with heights from just 80 mm on.

Loads: 1 to 20.000 kg

Materials: Painted or galvanized sheet steel and pickled stainless steel

Controls: Electric switch cabinet with:

- On/Off switch with motor protection relay
- Frequency control and display
- Brakes
- Timers
- Remote controls and much more.

Electro-pneumatic controls in terminal boxes:

- Control valves
- Throttles
- Maintenance units

Multiple-shaft vibration system



In individual cases, the required drive can only be determined by means of testing. We provide free test devices (excl. transport costs) for this purpose.

Design: The electric or pneumatic vibrators are attached to the inflexible plate of the vibrating table. The plate is connected to the base via a vibration-optimized spring suspension.

Applications

Electrical, Electronic and Precision Engineering Industries	
Inspection	of connections, individual parts or complete devices for cold solder spots, hairline cracks, functional errors, natural resonancies
Simulation	of transport movements, mechanical environmental influences
Untangling, separating, distributing, aligning	of small parts, such as screws, bolts, springs, hooks, rings, etc. prior to hand-assembly or automatic processing on assembly lines
Testing	of electrical components and devices (mechanical vibration tests)

Car Industry, Vehicle Construction	
Inspection (Durability tests)	of small add-on parts, such as carburetors, coils, valves, mechanical and electrical connections, safety devices, headlights, exterior mirrors, etc. for functional errors, hairline cracks, natural resonancies, wear

Food, Packaging and Chemical Industries	
Compaction	of loose products in small containers, such as barrels, cardboard drums, cartons, bags etc.
Flattening, distributing	of granules before closing packages
Loosening	of products which have become compacted during transport or storage, prior to further processing
Sedimentation	of solid materials out of suspensions
Levelling	of sacks and bags, prior to palletising or stacking

Construction industry	
Compaction	of concrete blocks, on the construction site or in the test laboratory



VTF/R 10/12 with 2 NEG 251370 E for applications conforming to ATEX



VTH/W 12/12 with 2 NEG 501510 for a weighing machine

NetterVibration offers the accessories required for the mounting, installation, control and monitoring of vibrators and vibrating tables.

Netter provides solutions. Consult our experienced application technicians.

Netter GmbH

Germany

Fritz-Ullmann-Str. 9
55252 Mainz-Kastel
Tel. +49 6134 2901-0

Poland

Al. W. Korfatego 195/17
40-153 Katowice
Tel. +48 32 2050947

Switzerland

Erlenweg 4
4310 Rheinfelden
Tel. +41 61 8316200

Spain

Errota Kalea 8
20150 Villabona-Guipúzcoa
Tel. +34 943 694 994

www.NetterVibration.com
info@NetterVibration.com

11/2014 Subject to change without notice

Netter questionnaire for the preparation of a quotation

please tag whatever is applicable

1. Application :

- **Compaction of bulk materials in containers**
- **Compaction of refractory materials**
- **Compaction of foundry moulding sand**
- **Compaction of prefabricated concrete parts**
- **Compaction of polymer concrete**
- **Levelling of pouring cones and distribution**
- **Flattening of bags**
- **Removal of sticky material on parts etc.**
- **Loosening of wire coils for further processing**
- **Separation of parts sticking together**
- **Cleaning off material sticking to work pieces**

Container:

- Type of container:
- Carton Cardboard drums Steel barrels Forms
- Octabins Containers Big Bags
- Other containers
- Dimensions (length • width • height): [mm]
- Weight: [kg]

Content :

- Product designation:
- Bulk weight: [kg/m³]
- Consistency:
 - powdery grainy doughy moist sticky bulky
- Weight of the total content: [kg]

Desired size of vibrating table:

- Size of vibrating plate (length • width): [mm]
- From top side of table plate to floor: [mm]

Installation situation:

Roller track

- Installation into existing roller track
- Vibrating table with roller track
- Roller diameter: [mm] Roller distance: [mm]
- Top edge of roller to floor: [mm] Width of roller track: [mm]
- not driven driven : Conveying speed: [m/min]

Scale

- Installation on a scale
- Installation above a scale
- Dimensions of scale (width • depth • height): [mm]



Pit

- Installation in a pit, top side of vibration table is level with floor
- Dimensions of pit (length • width • depth): [mm]
- Application of container:
 - Manual lift truck Fork lift truck Crane

Conveyor belt

- Installation into a conveyor belt
- Width of belt[mm] Distance between top and bottom belt [mm]
- Top side of upper belt to floor: [mm]

Other versions

- Flat design
- Desired height from top side of table plate to floor: [mm]
- Portable version
- Moveable

• Tests, material and product tests

- Mechanical vibration test according to own requirements or standards.
- Simulation of transport movements or environmental influences.
- Other application:
- Desired frequency:
 - Fixed frequency in [Hz] or [oscillations / min.]
 - Controllable up to in [Hz] or [oscillations / min.]
- Desired acceleration:[a_(g) = multiple of the acceleration due to gravity]
- Desired oscillation width:[mm]
- Desired direction of oscillation:
 - circular vertical directed vertical
 - circular horizontal directed horizontal
- Desired timing range or number of cycles (please describe) :
.....

• Other applications

Please describe, if possible add a sketch:.....
.....
.....

2. Environmental influences (please describe) :

- Ambient temperature: [°C]
- Humidity (e.g. spray water):
- Caustic atmosphere:
- Other environmental influences:

3. Type of drive :

- *Compressed air*
 - Available pressure: [bar]
 - Supply quantity: [m³ / min]
- *Electric*
 - Available voltage and mains frequency: [V] [Hz]
 - Explosion protection , if yes: Information about the explosion protection class:

4. Control :

- By customer Specify interface:
- Offer

5. Address :

Company :.....
Name :..... Department :.....
Country:
Place :.....
Street :.....
Phone :..... Fax :.....
Internet address:..... E-mail :.....

Netter GmbH
Germany
Fritz-Ullmann-Str. 9
55252 Mainz-Kastel
Tel. +49 6134 2901-0

Poland
Al. W. Korfantego 195/17
40-153 Katowice
Tel. +48 32 2050947

Switzerland
Erlenweg 4
4310 Rheinfelden
Tel. +41 61 8316200

Spain
Errota Kalea 8
20150 Villabona-Guipúzcoa
Tel. +34 943 694 994
www.NetterVibration.com
info@NetterVibration.com

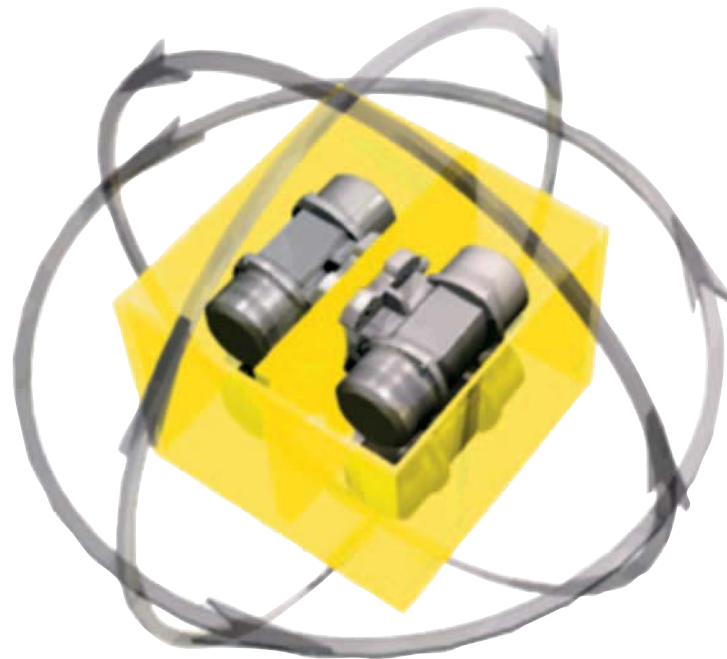

37

Netter Multiple-Shaft Vibration Systems Series *VectorDrive*



- 100% controlled vibration in each direction
- Resonance-free start and stop
- Amplitude adjustment during operation
- Frequency control during operation
- Constant acceleration with varying loads
- Prevention of resonance and associated noise
- Operating times of less than 1 second possible
- Control loops for acceleration possible

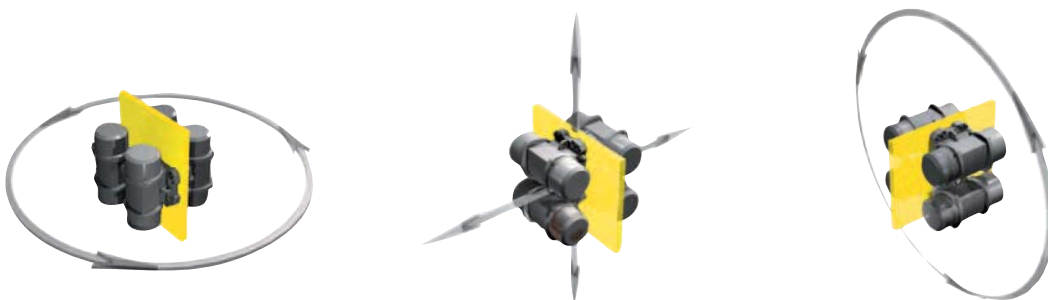



Netter Multiple-Shaft Vibration Systems Series *VectorDrive*

Horizontal arrangement of vibrators

E.g. for mixing, feeding, compacting and rocking

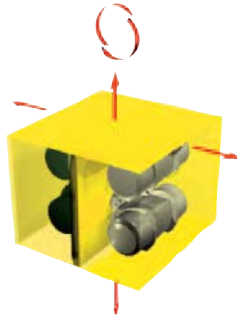

Vertical arrangement of vibrators

E.g. for mixing, tumbling, compacting and sieving

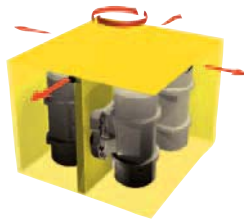

Linear arrangement of vibrators

(compact mounting)

E.g. for feeding, compacting and rocking



VectorDrive



Visual aging of paving stones

Applications:

The multiple-shaft vibration system **VectorDrive** offers a multitude of application possibilities.

The resonance-free starting and stopping, together with independent regulation of the working direction, frequency and amplitude open up new possibilities for compacting, mixing, feeding and distributing.

Design and Function:

The **VectorDrive** system consists of a control unit and at least 4 vibrators.

For an electric vibrator there are generally two operating conditions and two transitional phases: standstill (no vibration), nominal rotational speed (vibration) and deceleration up to nominal rotational speed or deceleration down to standstill. Often, however, only the two operating conditions, standstill and nominal rotational speed, are desired, since detrimental resonance zones must be passed through in the transitional phases.

Example: Bulk material is optimally compacted using external vibrators at 3000 revs/min. When passing through rotational speeds between 1700 revs/min and 1300 revs/min, undesirable loosening can occur. The best solution would be to simply switch on the vibration at the nominal rotational speed and then switch it off again.

The control unit of the **VectorDrive** system makes this desired "on/off" effect (vibration / no vibration) possible.

Within a fraction of a second, the unbalances are positioned with each other in a way that allows the required centrifugal force and working direction.

Independent of the arrangement of the vibrators on the table, it is possible to create circular vibrations, as well as linear vibrations, by a change of the working direction. The various working directions can be controlled successively during operation, also with changing frequencies and amplitudes.

The **PowerCube** is the preferred variant for the arrangement of the vibrators. The vibrators, in this case, are arranged in a cube under the table. The vibrators can be easily rearranged by dismounting and rotating the cube. Of course, it can just as easily be mounted under a different table construction.

Netter supplies solutions. Consult our experienced application technicians.

Netter GmbH

Germany

Fritz-Ullmann-Str. 9
55252 Mainz-Kastel
Tel. +49 6134 2901-0

Poland

Al. W. Korfantego 195/17
40-153 Katowice
Tel. +48 32 2050947

Switzerland

Erlenweg 4
4310 Rheinfelden
Tel. +41 61 8316200

Spain

Errota Kalea 8
20150 Villabona-Guipúzcoa
Tel. +34 943 694 994

www.NetterVibration.com
info@NetterVibration.com



44

Netter Dosing Station Series *DosyPack*



- Exact dosing
- High conveying performance
- Gentle and uniform dosing
- Adjustable fine or coarse flow
- All product-carrying parts made of stainless steel 1.4301
- High surface quality
- Quick and easy to clean



*DosyPack*4



DosyPack 40



DosyPack 56



Netter Dosing Station Series *DosyPack*

Example	Product Characteristics		Feed Rate [g/s]		Noise Level [dB(A)]
	Grain Density [kg/dm ³]	Grain Size [mm]	<i>DosyPack</i> 4	<i>DosyPack</i> 25 bis 80	
Sand	1,54	0 - 1	0 - 20	0 - 260	56 - 75
Granulate	0,70	1 - 3	-	0 - 150	56 - 75
Plastic caps	0,20	Ø 10	-	0 - 25	56 - 73

The technical data relate to the examples given and can vary, depending on the product.

Type	A [mm]	B [mm]	ØC [mm]	D [mm]	E [mm]	□ F [mm]	G [mm]	V (Container volume) [l]	Weight [kg]
<i>DosyPack</i> 4	420	480	200	190	175	290 x 150	105	4	5,5
<i>DosyPack</i> 25	729	710	381	241	190,5	430 x 280	261	25	15,0
<i>DosyPack</i> 40	729	860	381	241	190,5	430 x 280	261	40	16,8
<i>DosyPack</i> 56	805	844	533	241	190,5	430 x 280	261	56	26,3
<i>DosyPack</i> 80	805	994	533	241	190,5	430 x 280	261	80	29,5



Dosing port at the silo outlet

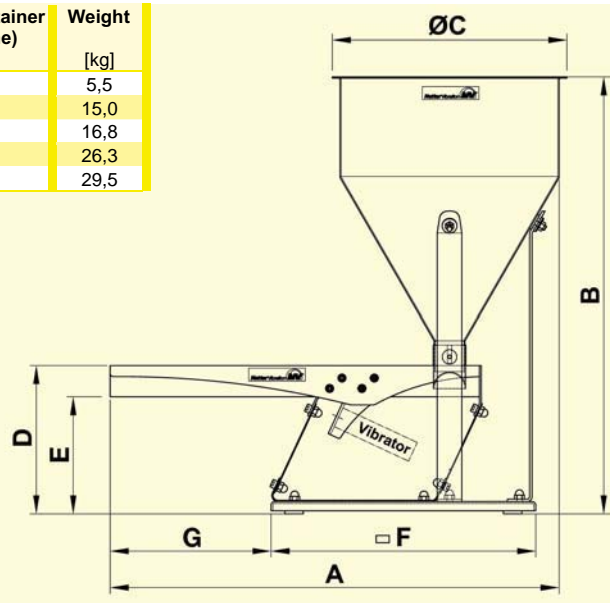

Applications

DosyPack dosing stations are particularly suitable for the fast and exact dosing of all types of bulk material, or as feeders for optical sorting facilities. Gentle dosing is possible for especially sensitive products.

Design and functioning principle

The dosing station basically consists of a conveyor channel mounted on leaf springs and a silo. All product-carrying parts are made of brushed stainless steel ($R_a=0,25$, $R_z=1$), all other parts are made of corrosionresistant and physiologically harmless materials.

Because of the functional design *DosyPacks* are fast and easy to clean. This allows it to be used even under the extreme hygienic conditions demanded by the chemical, pharmaceutical and food industries.

The flow rate can be varied with the dosing port at the silo outlet.

Pneumatic linear vibrators series NTS and NTK may be selected for driving. They work without running on, so that the product flow is immediately interrupted, once the vibrators are switched off.

The exact feed quantity is regulated by adjusting the frequency and amplitude of vibration. Both can be independently adjusted. Increasing the supply pressure causes an increase in the frequency. The amplitude can be adjusted by regulating the optional throttle.

A multi-directional valve is required for operation (not supplied).

In addition to the standard versions, series *DosyPack* dosing stations are also available in customized designs. Furthermore, all individual components can be supplied separately.

Permissible operating conditions

Drive medium:

Compressed air or nitrogen (filter $\leq 5 \mu\text{m}$), preferably with oil mist

Operating pressure:

2 bar to 6 bar

Ambient temperature:

5°C to 60°C

NetterVibration offers the accessories required for the mounting, installation, control and monitoring of vibrators and impactors.

Netter provides solutions.

Consult our experienced application technicians.

Netter GmbH

Germany

Fritz-Ullmann-Str. 9
55252 Mainz-Kastel
Tel. +49 6134 2901-0

Poland

Al. W. Korfantego 195/17
40-153 Katowice
Tel. +48 32 2050947

Switzerland

Erlenweg 4
4310 Rheinfelden
Tel. +41 61 8316200

Spain

Errota Kalea 8
20150 Villabona-Guipúzcoa
Tel. +34 943 694 994

www.*NetterVibration.com*
info@*NetterVibration.com*

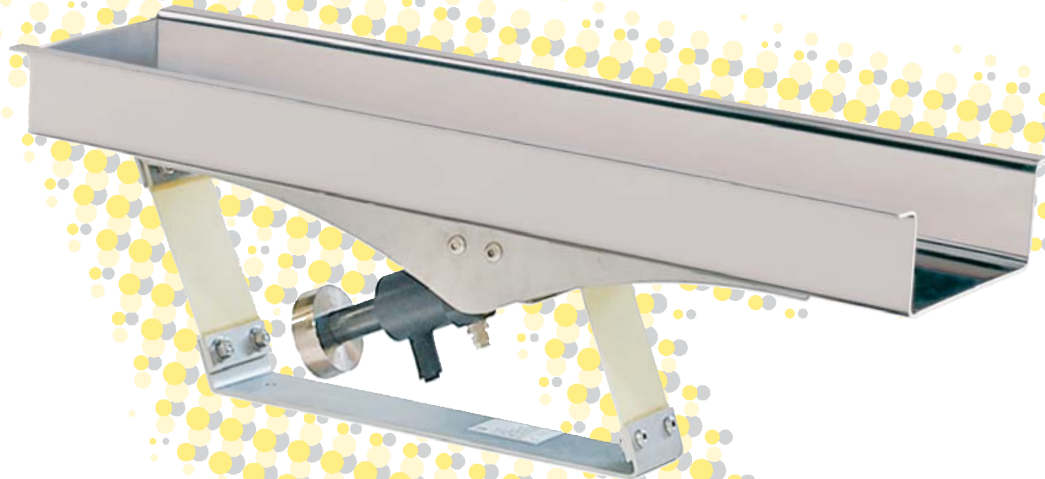

46

Netter Conveyor Systems Series *PowerPack*



- Gentle and smooth conveying
- Coarse and fine flow settings
- Instant starting and stopping
- Stainless steel version possible





Netter Conveyor Systems Series *PowerPack*

Type	A [mm]	B [mm]	C [mm]	D [mm]	E [mm]	F [mm]	G [mm]	ØH [mm]	Weight without trough [kg]
PowerPack 180	500	170	85	80	343	230	93	9	ca. 2,1
PowerPack 250/350	580	173	100	80	442	321,5	94	9	ca. 3,6

Conveyor systems of the PowerPack series consist of:



A conveyor trough, manufactured either by the client or as per the client's requirements,

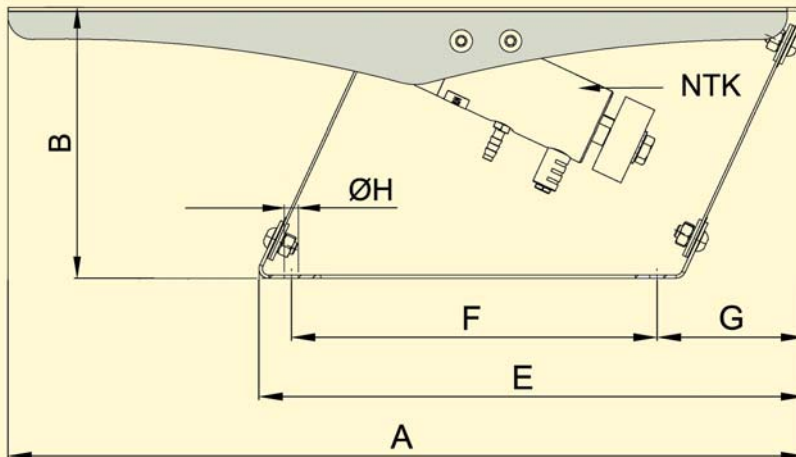
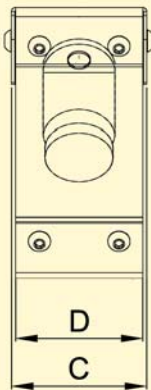

the upper part,
the blade springs,
pneumatic linear vibrators of series NTK or NTS
and the lower part.

Applications

Conveyor systems of the **PowerPack** series serve to convey bulk material efficiently and gently. The stainless steel version allows the operation in the chemical, pharmaceutical and food industries.

Design and functioning principle

The **PowerPack** feeder system works with forced vibrations. The conveyor trough is mounted on blade springs and is driven by a pneumatic linear vibrator of the NTK or NTS series. Depending on the application, it is also possible to use an electric external vibrator of the NEG series. The selection of the vibrator depends not only on the material properties, but also on the requested frequency or amplitude. Unlike many other conveyor systems, the frequency and amplitude of the **PowerPack** series can be controlled separately. It is therefore possible to satisfy many individual requirements.

In addition to the general standard versions, customized versions of the **PowerPack** series are also available. Furthermore, all components can be supplied separately.

Permissible operating conditions:

Drive medium:

Compressed air or nitrogen (Filter 5 µm), preferably with oil mist.

Operating pressure:

2 bar to 6 bar

Ambient temperature:

5°C to 60°C
HT versions up to 200°C

NetterVibration offers the accessories required for the mounting, installation, control and monitoring of vibrators and impactors.

Netter provides solutions.

Consult our experienced application technicians.

Netter GmbH

Germany

Fritz-Ullmann-Str. 9
55252 Mainz-Kastel
Tel. +49 6134 2901-0

Poland

Al. W. Korfantego 195/17
40-153 Katowice
Tel. +48 32 2050947

Switzerland

Erlenweg 4
4310 Rheinfelden
Tel. +41 61 8316200

Spain

Errota Kalea 8
20150 Villabona-Guipúzcoa
Tel. +34 943 694 994

www.**NetterVibration.com**
info@**NetterVibration.com**



47

Netter Conveyor System Series *LineDrive*



- Gentle and constant conveying
- Flat, compact construction
- Modularly extendable
- Low air consumption
- Very low noise level





Netter Conveyor System Series *LineDrive*

The conveyor system of the **LineDrive** series consist of:



a conveyor trough,
manufactured either
by the client or
as per client's
requirements,

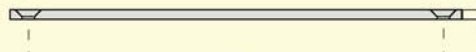

the mounting plate
(optional)

LineDrive support NLD 25 A

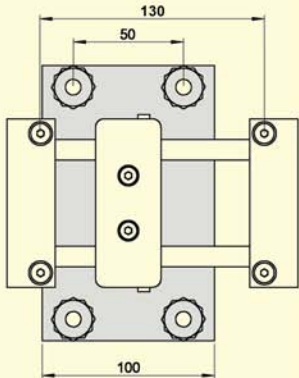
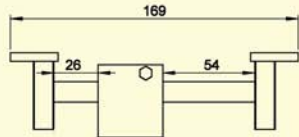

The LineDrive support is required
as support for longer conveyors or
for greater loads as well.

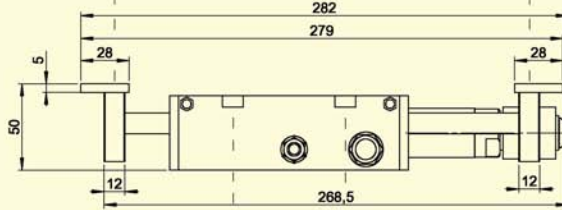

the **LineDrive**
unit,
driven by a
linear vibrator



and the ground plate
(optional).

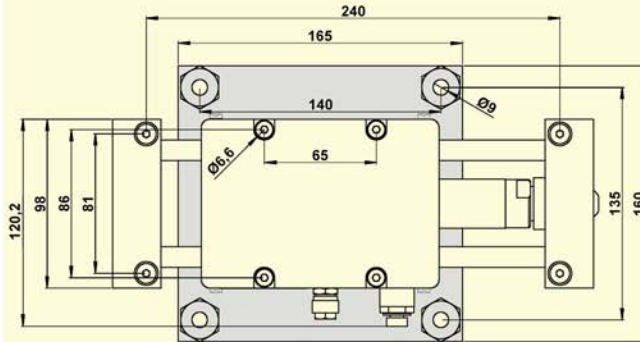

Conveyor system **LineDrive**



trough



mounting plate



drive unit



ground plate



support

Applications

The **LineDrive** conveyor system is suitable for gentle, horizontal conveying of bulk material. The flat design (height of drive 5 cm) allows applications even with confined space constraints.

Design and functioning principle

Traditional vibration conveyor systems work on the throwing principle, in which the product is "thrown" forward, following a trajectory parabola. With the **LineDrive** conveyor principle, the material slides along the conveyor trough. This is made possible by a pneumatic linear drive.

The conveyor output can be adjusted to suit the specific characteristics of the material to be conveyed by regulating the compressed air. In longer conveyor systems (from approx. 2m), the trough is supported by the **LineDrive** support. It is possible to convey greater loads by coupling several **LineDrive** propulsion systems.

In addition to the standard versions, customized variants of the **LineDrive** series are also available.

Mounting plates

The mounting plates are suitable for mounting the entire surface of the conveyor troughs on a **LineDrive** unit.

Baseplates

The ground plates are used to compensate unevenness in order to avoid any tensioning in the **LineDrive** unit.

Permissible operating conditions:

Drive Medium:

Compressed air or nitrogen (filter $\leq 5 \mu\text{m}$), preferably with oil mist

Optimum Operating pressure:

2 bar.

Ambient temperature:

5°C to 60°C

Weight without trough:

2,7 kg

NetterVibration offers the accessories required for the mounting, installation, control and monitoring of vibrators and impactors.

Netter provides solutions.

Consult our experienced application technicians.

Netter GmbH

Germany

Fritz-Ullmann-Str. 9
55252 Mainz-Kastel
Tel. +49 6134 2901-0

Poland

Al. W. Korfatego 195/17
40-153 Katowice
Tel. +48 32 2050947

Switzerland

Erlenweg 4
4310 Rheinfelden
Tel. +41 61 8316200

Spain

Errota Kalea 8
20150 Villabona-Guipúzcoa
Tel. +34 943 694 994

www.NetterVibration.com
info@NetterVibration.com

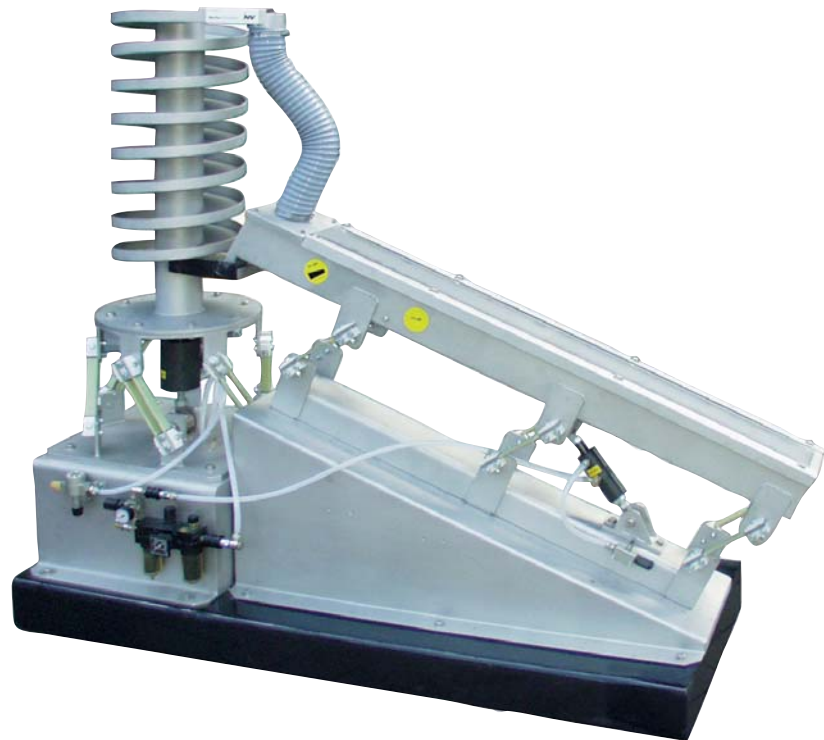

45

Netter Resonance Conveyor System Series *FlexiLink*



- High conveying performance by use of spring resonance
- Low air consumption
- Immediate starting and stopping
- Low unit weight





Netter Resonance Conveyor System Series *FlexiLink*

Netter resonance conveyor systems in the FlexiLink series consist of:

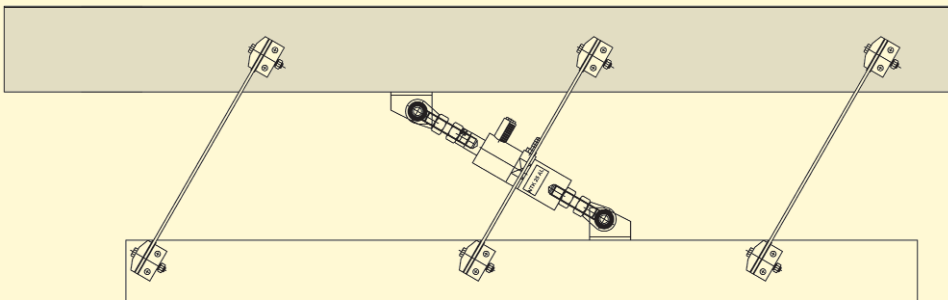

A conveyor trough, manufactured either by the client or as per the client's requirements

blade springs,
a pneumatic linear vibrator series NTK with the *FlexiLink* connecting element

and the counter-weight (frame/floor)

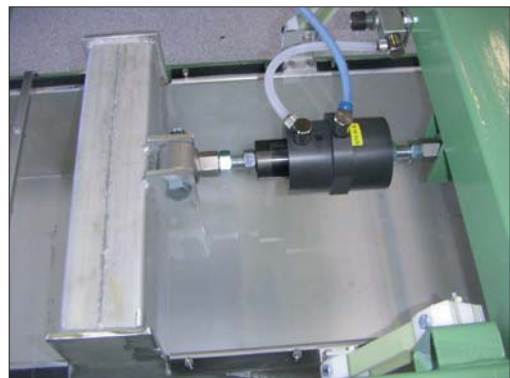

Applications

Conveyor systems of the *FlexiLink* series serve to convey bulk material efficiently and gently.

Design and functioning principle

The feeder system consists of a pneumatic linear vibrator of series NTK, blade springs and the *FlexiLink* connecting element.

This system uses the natural resonance of the springs in order to convey bulk materials. Once the trough starts to vibrate at the resonance frequency, very little additional energy is required to maintain the vibration. Even with varying loads, the trough continues to vibrate in resonance.

The amplitude can be adjusted by means of an optional exhaust throttle.

In addition to driving classic feeder troughs, the *FlexiLink* system can also be used to drive spiral feeders. The blade springs are then arranged in a circle in order to

accommodate the spiral feeder.

In addition to the standard versions, customized variants of the *FlexiLink* series are also available. Furthermore, all components can be supplied separately.

Permissible operating conditions:

Drive Medium:

Compressed air or nitrogen (filter $\leq 5 \mu\text{m}$), preferably with oil mist

Operating pressure:

2 bar to 6 bar

Ambient temperature:

5°C to 60°C

NetterVibration offers the accessories required for the mounting, installation, control and monitoring of vibrators and impactors.

Netter provides solutions.

Consult our experienced application technicians.

Netter GmbH

Germany

Fritz-Ullmann-Str. 9
55252 Mainz-Kastel
Tel. +49 6134 2901-0

Poland

Al. W. Korfatego 195/17
40-153 Katowice
Tel. +48 32 2050947

Switzerland

Erlenweg 4
4310 Rheinfelden
Tel. +41 61 8316200

Spain

Errota Kalea 8
20150 Villabona-Guipúzcoa
Tel. +34 943 694 994

www.NetterVibration.com
info@NetterVibration.com

You have the opportunity for a free demonstration or trial of our devices, with no further obligation. In order for us to serve you quickly and effectively, we request that you complete this questionnaire.

Application

Emptying bunkers (Provide main dimensions on reverse)
Slides / chutes (Provide main dimensions on reverse)
Compaction of

Material Consistency

Specific weight kg/l% moistness

<input type="checkbox"/> dry	<input type="checkbox"/> sticky	<input type="checkbox"/> granulated
<input type="checkbox"/> moist	<input type="checkbox"/> slimy	<input type="checkbox"/> can be trickled
<input type="checkbox"/> dusty	<input type="checkbox"/> flaky	<input type="checkbox"/> splintery
<input type="checkbox"/> powdery	<input type="checkbox"/> fine-grained	<input type="checkbox"/> coarse-grained

Environmental Conditions

normal ambient temperature°C
 warm radiation very damp (water spray)
 corrosive atmosphere Ex protection required
 other

Pneumatic Vibrators

What is the operating pressure of your compressor system? bar
What is the power of your compressor?
(Alt. enter kW) m³/min (induced air)
How high is the loading of your compressor? low normal to the limit
Must exhaust air be dissipated? yes no

Electric Vibrators

Which type of voltage is required?
 230 V, 3-phase 230/400 V, 50 Hz special voltage
Which vibrators are you particularly interested in?
 Pneumatic vibrators Electric vibrators
 Hydraulic vibrators The most suitable device
dependant on application



NetterVibration

If you have already performed tests or currently work with other vibrators, please enter the following details:

Frequency vibrations/min
Centrifugal force N
Drive electric pneumatic

If these data are not known, please enter the type and manufacturer
Type:..... Manufacturer:.....

What improvements or modifications do you expect? What are you not pleased about?

Sketch (include extra sheet if necessary)
Please enter main dimensions!

Company Name:

Street: Department:

Town: Who is directly responsible for this matter?

Telephone:

Date: Name:

Required

- Offer with proposal
- Test device(s)
- Demonstration

Netter GmbH

Germany
Fritz-Ullmann-Str. 9
55252 Mainz-Kastel
Tel. +49 6134 2901-0

Poland
Al. W. Korfanteo 195/17
40-153 Katowice
Tel. +48 32 2050947

Switzerland
Erlenweg 4
4310 Rheinfelden
Tel. +41 61 8316200

Spain
Errota Kalea 8
20150 Villabona-Guipúzcoa
Tel. +34 943 694 994

www.**NetterVibration.com**
info@**NetterVibration.com**

11/2014 Subject to change without notice



49

Netter Hydraulic Vibrating Unit Type NHW



- Mobile wagon emptying device
- Quick-change connector for any carrier
- Driven via the on-board hydraulic system of the carrier vehicle, e.g. wheel loader



NHW with quick-change connector



NHW without protective cover



Netter Hydraulic Vibrating Unit Type NHW

Type	Working torque [cmkg]	Frequency [min ⁻¹]	Centrifugal force [N]	Oil requirement [l/min]	Noise level [dB(A)]
NHW	219	3.000	Up to 108.066	49	>80

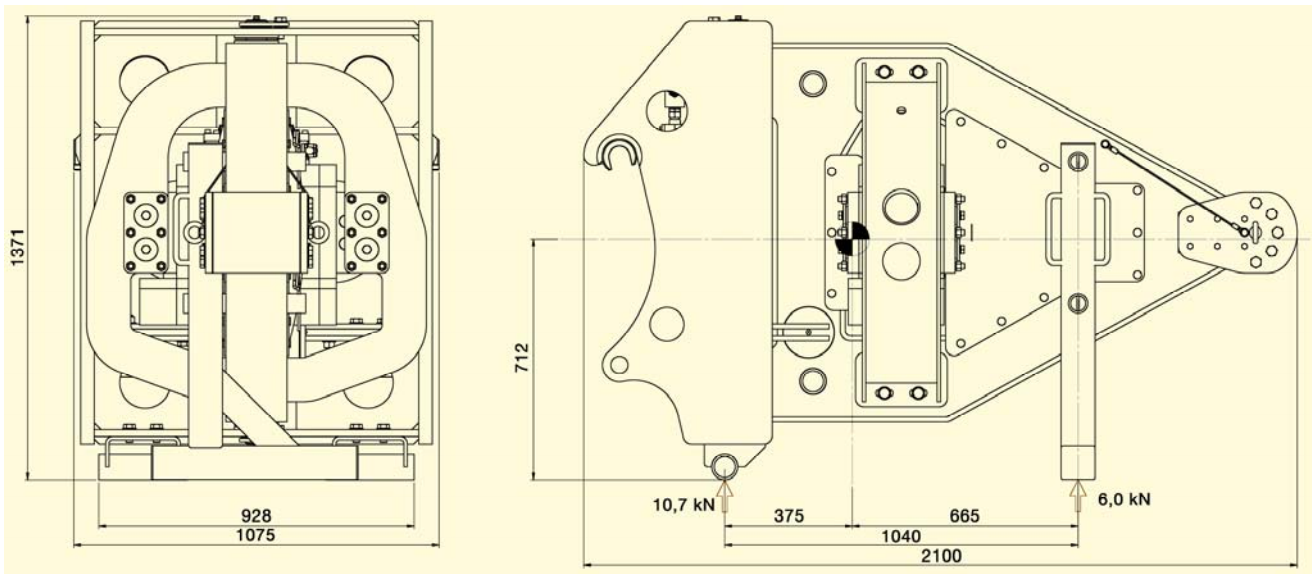

Wheel loader with vibrating unit NHW



Emptying device on the wagon



Cleaning from adhering ashes

Applications

The hydraulic wagon emptying device series NHW serves to clean adhesions from wagons.

Design and functioning

The vibrating unit is operated on a carrier (preferentially a wheel loader) with quick-change connector.

The vibrating part of the NHW generates vibrations. These vibrations are transmitted to the contact point on the wagon via a push rod. This energy input causes the wagon to vibrate, thus cleaning existing adhesions and incrustations from the wagon.

Permissible operating conditions

Drive medium:

Mineral oil according to DIN 51524/25,
Motor oil according to DIN 51511,
Bio oils of the group "HEES"

Operating pressure:

60 to 250 bar

Ambient temperature:

-20°C to 50°C

NetterVibration offers the accessories required for mounting, installation, control and monitoring of vibrators and impactors.

Netter provides solutions.
Consult our experienced application technicians

Netter GmbH

Germany

Fritz-Ullmann-Str. 9
55252 Mainz-Kastel
Tel. +49 6134 2901-0

Poland

Al. W. Korfantege 195/17
40-153 Katowice
Tel. +48 32 2050947

Switzerland

Erlenweg 4
4310 Rheinfelden
Tel. +41 61 8316200

Spain

Errota Kalea 8
20150 Villabona-Guipúzcoa
Tel. +34 943 694 994

www.**NetterVibration.com**
info@**NetterVibration.com**

Special Equipment

NetterVibration



<p>Stainless-steel vibrators are resistant against extremely aggressive ambient conditions. Especially the chemical, pharmaceutical and food industry use this resistance in production areas with aggressive liquids and gases.</p>	
<p>Special constructive measures in ATEX vibrators permit them to be used in potentially explosive areas (ATEX zones 1, 2, 21 and 22) where they are operated in the presence of gases, vapors, mist and dust. This equipment which meets very high safety standards is used above all in the chemical and mineral oil industry.</p>	
<p>Lubrication-free vibrators can be operated with dry compressed air due to special materials and coatings. The pharmaceutical and food industry use this lubrication-free devices with dry, lubrication-free compressed air in production areas of the medical and clean-room technology.</p>	
<p>High-temperature vibrators are suitable for use at ambient temperatures up to 500°C (depending on the version). The use of special materials, coatings and components permits the operation of the devices at very high temperatures. In particular foundries and the energy industry use high-temperature equipment for their applications (emptying of moulding boxes, cleaning of electrostatic precipitators).</p>	
<p>Special materials and coatings permit low-temperature vibrators to be used at temperatures up to -32°C depending on the version. This type of equipment is required by the pharmaceutical, chemical and food industry for their low temperature areas.</p>	
<p>Plastic vibrators provide the benefits of stainless steel devices, but weigh considerably less and depending on the design can be operated with lubrication-free compressed air. Thanks to the beneficial properties of these devices they can be used for the production of dairy products (e.g. cheese), in all areas of the food industry and for extreme industrial applications.</p>	

Series	Stainless steel	ATEX	Lubrication-free	High temperature	Low temperature	Plastic
PKL	•	•	•	•	•	
NTK	•	•	•	•	•	•
NTS	•	•	•	•	•	•
NTP	•	•	•	•	•	•
NCT	•	•	•	•	•	
NCB	•			•	•	
NCR				•	•	
NVT		•				
NVE		•				
VT	•	•				
KRD		•				
NWE	•	•				
VAC	•	•	•		•	
NES	•	•	•			
NEG	•	•	•			•



NetterVibration



Vibrators For Industrial Purposes



Loosening hard crusts
with pneumatic linear vibrators



Loosening product compaction
with pneumatic circular oscillators



Gentle conveying and dosing of
bulk materials with conveyor trays



Sieving coarse bulk material
with electric external vibrators

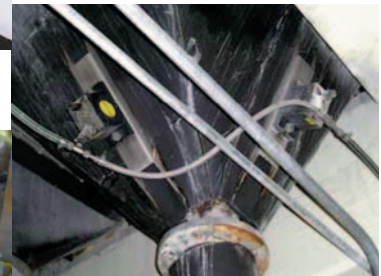

Eliminating bridging with
pneumatic circular oscillators



Compacting / levelling materials in a production
line with a vibrating table



Conveyor sieving tray, driven by stainless
steel electric external vibrators



Conveying with stainless steel
electric external vibrators



Easing, loosening
wire coils with
electric external
vibrators

Applications

Vibrators supplied by **NetterVibration** are used in many industrial branches.

Applications include simple loosening of adhesions, maintaining product flow and compacting.

A special part of vibration technique is conveyor technology. The systematic use of resonance effects and material properties allows conveyor performances which would require considerable effort if other technologies were used.

In addition to the standard devices, **NetterVibration** offers a wide range of special solutions, adapted to suit the

individual requirements of the client.

NetterVibration has a worldwide staff of experienced application engineers and field representatives. We would be pleased to offer advice on site and to help optimize your applications using vibration technology.

We would be pleased to prove our consulting competence in connection with a free trial of our test units.

Netter provides solutions. Consult our experienced application technicians.

Netter GmbH

Germany

Fritz-Ullmann-Str. 9
55252 Mainz-Kastel
Tel. +49 6134 2901-0

Poland

Al. W. Korfantego 195/17
40-153 Katowice
Tel. +48 32 2050947

Switzerland

Erlenweg 4
4310 Rheinfelden
Tel. +41 61 8316200

Spain

Errota Kalea 8
20150 Villabona-Guipúzcoa
Tel. +34 943 694 994

www.NetterVibration.com
info@NetterVibration.com

03/2016 Subject to change without notice