



NetterVibration In the Construction Industry

- Internal vibrators
- External vibrators
- Vibrating beams
- Vibrating tables
- Vibration rigs
- Accessories



Electric internal vibrator



Pneumatic external vibrator



Frequency converter



NetterVibration



Vibrators for the Construction Industry



Excavator equipped with hydraulic internal vibrators from the NHR series, for compacting bulk concrete



Silent compaction of prefabricated parts using a vibrating table from the **GyroShake**® series



Compaction of concrete on a steel formwork using external vibrators from the NEG series



Tunnel formwork with pneumatic external vibrators from the NVT series



Electric external vibrators from the NEG series on a pipe form



Compacting concrete in a building, using electric internal vibrators from the NCZ series

Applications

NetterVibration supplies electric, pneumatic and and hydraulic internal and external vibrators for commercial compaction of concrete.

Our vibrators perform convincingly, both on building sites and in the production of prefabricated parts, due to the efficiency of compaction and the high surface quality of the concrete.

Small vibrating tables are used for testing concrete, larger vibrating tables (**GyroShake**® series) for the production of prefabricated parts.

NetterVibration has a worldwide network of experienced application engineers and field representatives, who will willingly assist clients with the application of vibration technology to solve problems on site.

We will be pleased to demonstrate our consulting competence in connection with a free trial of our test units.

NetterVibration also supplies accessories, mountings and frequency converters to suit your specific application.

Netter provides solutions.
Consult our experienced application technicians.

Netter GmbH

Germany

Fritz-Ullmann-Str. 9
55252 Mainz-Kastel
Tel. +49 6134 2901-0

Poland

Al. W. Korfantego 195/17
40-153 Katowice
Tel. +48 32 2050947

Switzerland

Erlenweg 4
4310 Rheinfelden
Tel. +41 61 8316200

Spain

Errota Kalea 8
20150 Villabona-Guipúzcoa
Tel. +34 943 694 994

www.**NetterVibration.com**
info@**NetterVibration.com**



Unit description	Applications	Leaflet
Electric Internal Vibrators Series NCZ <ul style="list-style-type: none"> – Special suspension of the eccentric weight – Nominal frequency 12.000 min⁻¹ – Centrifugal force 1.160 N to 10.470 N – Compacting efficiency 16 m³/h to 65 m³/h – Head diameter 32–80 mm 	<ul style="list-style-type: none"> – Concrete compaction 	<div style="display: flex; align-items: center;"> <div style="border: 1px solid black; padding: 2px; margin-right: 5px;">1</div> </div>
Electric Internal Vibrators Series NCX <ul style="list-style-type: none"> – Nominal frequency 12.000 min⁻¹ – Centrifugal force 1.160 N to 6.000 N – Compacting efficiency 11 m³/h to 60 m³/h – Head diameter 39–66 mm 	<ul style="list-style-type: none"> – Concrete compaction 	<div style="display: flex; align-items: center;"> <div style="border: 1px solid black; padding: 2px; margin-right: 5px;">3</div> </div>
Electric Internal Vibrators for slip form pavers Series NCXM <ul style="list-style-type: none"> – Straight, elbow shaped and horizontal T-version – Nominal frequency 12.000 min⁻¹ – Centrifugal force 6.000 N – Head diameter 66 – 76 mm 	<ul style="list-style-type: none"> – Concrete compaction in slip form pavers 	<div style="display: flex; align-items: center;"> <div style="border: 1px solid black; padding: 2px; margin-right: 5px;">4</div> </div>
Electric Internal Vibrators Series NCE, NXE <ul style="list-style-type: none"> – Direct connection to 230 V – Low weight, easy handling – Nominal frequency 12.000 min⁻¹ – Centrifugal force 1.600 N to 6.500 N – Compacting efficiency 11 m³/h to 60 m³/h – Head diameter 32–59 mm 	<ul style="list-style-type: none"> – Concrete compaction 	<div style="display: flex; align-items: center;"> <div style="border: 1px solid black; padding: 2px; margin-right: 5px;">5</div> </div>
Pneumatic Internal Vibrators Series NVL <ul style="list-style-type: none"> – Adjustable speed – No bearings, therefore scarcely any wear – Centrifugal force 650 N to 34.300 N – Head diameter 25–140 mm 	<ul style="list-style-type: none"> – Concrete compaction 	<div style="display: flex; align-items: center;"> <div style="border: 1px solid black; padding: 2px; margin-right: 5px;">6</div> </div>
Electronic Frequency Converters Series NFC <ul style="list-style-type: none"> – Strong output power – Considerably lower weight compared to rotating converters – Switch off at overload and immediate restart – Phase control - protection of high frequency internal vibrators 	<ul style="list-style-type: none"> – Power supply for internal vibrators 	<div style="display: flex; align-items: center;"> <div style="border: 1px solid black; padding: 2px; margin-right: 5px;">31</div> </div>
Frequency and Voltage Converters Series FSW <ul style="list-style-type: none"> – Robust and approved design – Long lifetime – IP 54, isolation specification F – Primary 230 V or 400 V, 50 Hz – Secondary optional 42 V, 200 Hz or 250 V, 200 Hz 	<ul style="list-style-type: none"> – Power supply for internal vibrators – Power supply for electric external vibrators 	<div style="display: flex; align-items: center;"> <div style="border: 1px solid black; padding: 2px; margin-right: 5px;">33</div> </div>
Diesel Converters Series NFG <ul style="list-style-type: none"> – Robust and approved design – Designed for the construction industry – Long lifetime – Protection class IP 55 – Secondary: optional 42 V, 200 Hz or 250 V, 200 Hz 	<ul style="list-style-type: none"> – Power supply for internal vibrators – Power supply for electric external vibrators 	<div style="display: flex; align-items: center;"> <div style="border: 1px solid black; padding: 2px; margin-right: 5px;">34</div> </div>
Electric External Vibrators Series NEG <ul style="list-style-type: none"> – Supply voltage 230/400 V, 50/60Hz – Internal terminal box – Maintenance-free operation – Circular vibration – Adjustable with Netter frequency converters 	<ul style="list-style-type: none"> – Drives for conveyor and sieve – Loosening of adhesions and material blockages – Concrete compaction – Concrete compaction in concrete forms for precast part manufacturing, tunnel construction etc. 	<div style="display: flex; align-items: center;"> <div style="border: 1px solid black; padding: 2px; margin-right: 5px;">8</div> </div>



Leaflet

Unit description

Applications

Pneumatic External Vibrators Series NVT/NVR/NVG



14



- High frequency
- No wearout
- No bearings
- Quick displacement with quick release brackets
- Centrifugal force 7.130 N to 62.260 N

- Concrete compaction in concrete forms, tunnel construction
- Cleaning
- Loosening
- Emptying

Multiple-Shaft Vibration Systems Series VectorDrive

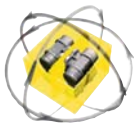

37



- Resonance-free start and stop
- Amplitude adjustment during operation
- Frequency control during operation
- 100% controlled vibration in each direction

- Compacting
- Conveying
- Mixing
- Distributing

Shaker Station for Concrete Compaction Series GyroShake

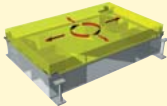

42



- Noise level below 70 dB(A)
- Vibrating table with min. 4 unbalance motors
- Frequency- and amplitude regulation during operation

- Concrete compaction in the precast part manufacturing

Hydraulic External Vibrators Series NHG L, Series CC, CV, CCV and DV



32

30



- Driven by the hydraulic motor
- Centrifugal force 1.750 N to 19.600 N

- Emptying of containers
- Operation at mobile machines

Hydraulic Internal Vibrators Series NVI



29



- Mounting at hydraulic loaders or excavators
- Automatic control
- Hydraulic supply with existing operation equipment of the carrier vehicle
- Variable mounting

- Mass Concrete Compaction

Vacuum Fixing Devices Series VAC



15



- Simple operation
- Quick attachment
- Integrated vacuum production

- Use of vibrators without solid mounting
- Application as vibration-tools for maintenance

Pneumatic Turbine Vibrators Series NCT



23



- Direct rotary vibration
- Very high rotary speed
- Centrifugal force 294 N to 8.537 N

- Loosening
- Conveying of bulk material
- Prevention of product locking

Pneumatic Linear Vibrators Series NTS



25



- Direct linear vibration
- Frequency and amplitude can be adjusted separately
- Synchronous operation from NTS 350 possible

- Drive of conveyors
- Loosening
- Compacting at concrete block making machines



Netter projecting of vibrating systems and energy requirements planning

We project complete studies of vibrator equipments for tunnel moulds, vibrating tables, batteries and in general for all concrete compaction duties. Our goal is to make you participate in our 50 years experiences in the field of vibrating. Our team of technicians is at your service to solve all kinds of vibrating problems.



1

Netter Electric Internal Vibrators Series NCZ and NCZ/S



- Higher centrifugal forces than conventional vibrators
- Special suspension of the eccentric weight
- Head tungsten carbide coating
- Maximum lifetime due to thermosensores
- Interchangeable elements
- Nominal frequency 12.000 min⁻¹
- Centrifugal force from 1.160 N to 10.470 N
- Compacting efficiency 16 m³/h to 65 m³/h
- 42 V to 48 V, 200 Hz or 250 V, 200 Hz



NCZ



NCZ/S



NetterVibration



Netter Electric Internal Vibrators Series NCZ and NCZ/S

Type	Head diameter	Head length	Head weight	Total weight	Hose length*	Cable length*	Nominal frequency	Centrifugal force	Influenced zone	Current consumption mean	Voltage*	Power (42 V)
	[mm]	[mm]	[kg]	[kg]	[m]	[m]	[min ⁻¹]	[N]	[cm]	[A]	[V]	[kW]
NCZ 300	32	320	1,7	7,9	5	10	12.000	1.160	40	8	42-48	0,6
NCZ 300 S	32	320	1,7	6,6	0,83	15	12.000	1.160	40	8	42-48	0,6
NCZ 370	38	360	2,9	9,6	5	10	12.000	1.400	45	8	42-48	0,6
NCZ 370 S	38	360	2,9	5,0	0,83	15	12.000	1.400	45	8	42-48	0,6
NCZ 480	49	400	5,1	14,2	5	10	12.000	3.100	60	15	42-48	1,1
NCZ 480 S	49	400	5,1	6,2	0,83	15	12.000	3.100	60	15	42-48	1,1
NCZ 560	58,5	400	6,8	15,9	5	10	12.000	4.850	65	23	42-48	1,6
NCZ 560 S	58,5	400	6,8	6,8	0,83	15	12.000	4.850	65	23	42-48	1,6
NCZ 560 L	58,5	450	7,8	16,8	5	10	12.000	6.100	75	21	42-48	1,5
NCZ 560 LS	58,5	450	7,8	9,2	0,83	15	12.000	6.100	70	21	42-48	1,5
NCZ 660	66	510	11,4	21,4	5	10	12.000	8.500	110	27	42-48	1,9
NCZ 800	80	440	13,8	29,0	5	10	12.000	10.470	160	35	42-48	2,5

*Other voltages, cable lengths and hose lengths on request

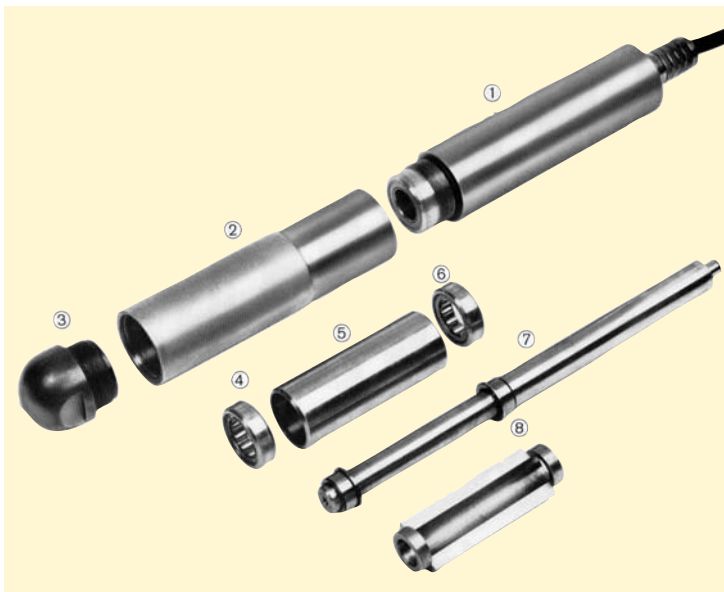

The Netter modular design:

8 interchangeable elements can be assembled without special tools on the construction site:

- 1 - stator with thermosensors (one per phase)
- 2 - body
- 3 - steel or rubber nose pieces
- 4 - ball or roller bearing
- 5 - spacer
- 6 - ball or roller bearing
- 7 - rotor
- 8 - eccentric weight made of bronze

Applications

The high power series NCZ and NCZ/S electric internal vibrators are particularly suitable for achieving high compaction performance with optimum extraction of air porosity, due to their enormous centrifugal forces.

NCZ vibrators thus fulfil the requirements of modern concrete technology.

The modular construction makes these internal vibrators very easy to service.

The special unbalance suspension and the long operating life of the bearings guarantee long-term reliability.

The coil is 100% protected from burning out by means of thermal sensors. In the event of overheating, the unit switches off automatically.

Series NCZ/S electric internal vibrators have a hand switch shaped like a pistol grip. The shorter connection hose is adapted to suit the special applications of concrete plants.

NCZ electric vibrators can be operated using all converters from 42 V to 48 V, 200 Hz .

NetterVibration supplies frequency and voltage converters suitable for all electric vibrators.

Permissible operating conditions

Voltage:
42 to 48 V, 200 Hz or 250 V, 200 Hz

Ambient temperature:
0°C to 40°C

Netter GmbH

Germany

Fritz-Ullmann-Str. 9
55252 Mainz-Kastel
Tel. +49 6134 2901-0

Poland

Al. W. Korfantego 195/17
40-153 Katowice
Tel. +48 32 2050947

Switzerland

Erlenweg 4
4310 Rheinfelden
Tel. +41 61 8316200

Spain

Errota Kalea 8
20150 Villabona-Guipúzcoa
Tel. +34 943 694 994

www.**NetterVibration.com**
info@**NetterVibration.com**

Netter provides solutions. Consult our experienced application technicians.



3

Netter Electric Internal Vibrators Series NCX and NCX/S



- Highest compacting rate in this price range
- Protection against burn-outs by thermal sensors
- Interchangeable elements, very easy to dismount
- Steel or vulcollan nosepiece
- Nominal frequency 12.000 min⁻¹
- Centrifugal force from 1.160 N to 6.000 N
- Compacting efficiency from 11 m³/h to 60m³/h
- 42 V to 48 V, 200 Hz



NCX



NCX/S



Netter Electric internal vibrators Series NCX and NCX/S

Type	Head diameter	Head length	Head weight	Total weight	Hose length*	Cable length*	Nominal frequency	Centrifugal force	Effective diameter	Current consumption	Voltage*	Power (42 V)
	[mm]	[mm]	[kg]	[kg]	[m]	[m]	[min ⁻¹]	[N]	[cm]	[A]	[V]	[kW]
NCX 380	39	370	2,9	9,5	5	10	12.000	1.200	40	7	42-48	0,5
NCX 380 S	39	370	2,9	5,0	0,8	15	12.000	1.200	40	7	42-48	0,5
NCX 480	49	375	4,7	15,2	5	10	12.000	3.000	55	18	42-48	1,3
NCX 480 S	49	375	4,7	6,2	0,8	15	12.000	3.000	55	18	42-48	1,3
NCX 580 L	59	400	7,8	17,0	5	10	12.000	4.800	65	25	42-48	1,8
NCX 580 LS	59	400	7,8	7,8	0,8	15	12.000	4.800	65	25	42-48	1,8
NCX 660 K	66	415	9,0	19,5	5	10	12.000	6.000	85	28	42-48	2,0

*Other voltages, cable lengths and hose lengths on request.

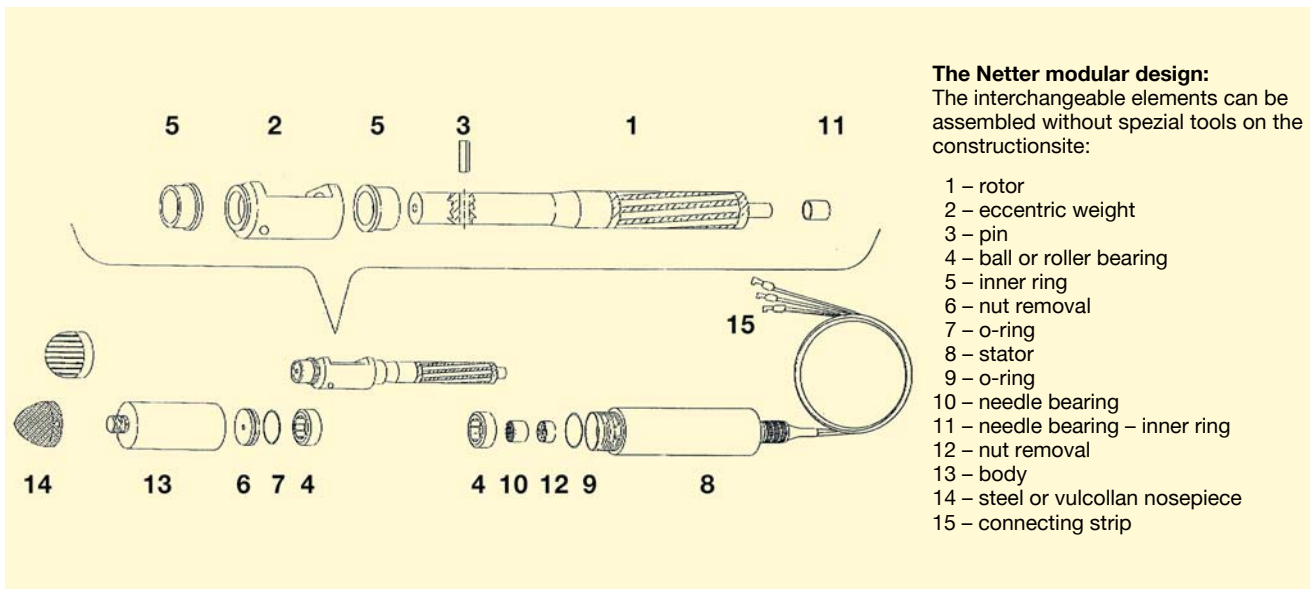

Design and functioning principle

The electric internal vibrators series NCX are particularly suitable for achieving high compaction performance with optimum extraction of air porosity, due to their enormous centrifugal forces. NCX vibrators thus fulfil the requirements of modern concrete technology. The modular construction makes these internal vibrators very easy to maintain.

The special unbalance suspension and the long operating life of the bearings guarantee long-term reliability.

The coil is 100% protected from burning out by means of thermal sensors. In the event of overheating, the unit switches off automatically.

Series NCX/S electric internal vibrators have a hand switch shaped like a pistol grip. The shorter connection hose is adapted to suit the special applications of concrete plants.

NCX electric vibrators can be operated using all converters from 42 V to 48 V, 200 Hz.

NetterVibration supplies frequency and voltage converters suitable for all electric vibrators.

Permissible operating conditions

Voltage:

42 to 48 V, 200 Hz

Ambient temperature:

0°C to 40°C

Netter GmbH

Germany

Fritz-Ullmann-Str. 9
55252 Mainz-Kastel
Tel. +49 6134 2901-0

Poland

Al. W. Korfanteo 195/17
40-153 Katowice
Tel. +48 32 2050947

Switzerland

Erlenweg 4
4310 Rheinfelden
Tel. +41 61 8316200

Spain

Errota Kalea 8
20150 Villabona-Guipúzcoa
Tel. +34 943 694 994

www.**NetterVibration.com**
info@**NetterVibration.com**

Netter provides solutions.
Consult our experienced application technicians.



Netter Electric Internal Vibrators for slip form pavers Series NCX M



- Highest compaction rate
- Interchangeable elements, very service friendly
- Straight, elbow shaped and horizontal T-version available
- T- vibrator with 2 different unbalances (CC version)
- 110 Volt, 200 Hz
- Optional thermal trips available



NCX M straight



NCX M elbow shaped



NCX M horizontal



5

Netter Electric Internal Vibrators Series NCE and NXE



- Direct connection to 230 V
- Light weight, easy handling
- Maximum lifetime due to thermal sensor
- Nominal frequency 12.000 min⁻¹
- Centrifugal force from 1.600 N to 6.000 N
- Voltage 230 V, 50–60 Hz, 1 phase





NetterVibration



Netter Electric Internal Vibrators Series NCE and NXE

Type	Head diameter [mm]	Head length [mm]	Total weight [kg]	Hose length* [m]	Cable length* [m]	Nominal frequency [min ⁻¹]	Centrifugal force [N]	Influenced zone [cm]	Current consumption mean [A]
NCE 300	32	320	12,2	2 or 5	10	12.000	1.160	40	3,5
NCE 370	38	360	12,5	2 or 5	10	12.000	1.400	45	3,7
NCE 480	49	400	18,5	2 or 5	10	12.000	3.100	60	6,1
NCE 560	58	400	22,0	2 or 5	10	12.000	4.850	65	8,0

* Other cable lengths and hose lengths on request

Type	Head diameter [mm]	Head length [mm]	Total weight [kg]	Hose length* [m]	Cable length* [m]	Nominal frequency [min ⁻¹]	Centrifugal force [N]	Influenced zone [cm]	Current consumption mean [A]
NXE 380	39	370	15,4	2 or 5	10	12.000	1.200	40	3,7
NXE 380 B	39	370	16,0	5	10	12.000	1.200	40	3,7
NXE 480	49	375	18,5	2 or 5	10	12.000	3.000	55	6,1
NXE 480 B	49	375	19,1	5	10	12.000	3.000	55	6,1
NXE 580 L	59	400	21,4	2 or 5	10	12.000	4.800	65	7,0
NXE 580 L B	59	400	22,0	5	10	12.000	4.800	65	7,0

* other cable lengths and hose lengths on request



NCE/NXE



NXE B

Design and functioning principle

Series NCE and NXE electric internal vibrators have an equivalent performance to those in the NCZ and NCX series. They differ in just one aspect. The NCE and NXE series have an electronic micro-converter with a hand switch integrated in the power cable, so that the internal vibrators can be connected directly to 230 V power sockets. In the NXE B version, the micro-converter is mounted separately, after the hand switch.

Permissible operating conditions

Voltage:
230 V to 240 V, 50 Hz to 60 Hz, 1 phase
Ambient temperature:
0°C to 40°C

Netter provides solutions. Consult our experienced application technicians.

Netter GmbH

Germany

Fritz-Ullmann-Str. 9
55252 Mainz-Kastel
Tel. +49 6134 2901-0

Poland

Al. W. Korfantego 195/17
40-153 Katowice
Tel. +48 32 2050947

Switzerland

Erlenweg 4
4310 Rheinfelden
Tel. +41 61 8316200

Spain

Errota Kalea 8
20150 Villabona-Guipúzcoa
Tel. +34 943 694 994

www.NetterVibration.com
info@NetterVibration.com



NetterVibration



Netter Electric Internal Vibrators Series NCX M

Type	Head diameter D [mm]	Total length L [mm]	Head length B [mm]	Head weight [kg]	Total weight [kg]	Nominal frequency [min ⁻¹]	Centrifugal force [N]	Influenced zone [cm]	Current consumption [A]	
straight	NCX M 660G	66	470	410	11,0	14,0	12.000	6.000	110	9,0
elbow	NCX M 660	66	490	390	11,0	20,0	12.000	6.000	110	9,0
	NCX M 760	76	640	480	16,5	28,0	12.000	9.000	150	11,0
horizontal	NCX M 760 T 4,0	76	343	480	20,0	30,0	12.000	4.000	150	11,0
	NCX M 760 T 5,6	76	343	480	20,0	30,0	12.000	5.600	150	11,0
	NCX M 760 T 7,2	76	343	480	20,0	30,0	12.000	7.200	150	11,0
	NCX M 760 T CC	76	343	480	20,0	30,0	12.000	5.600/ 7.200	150	11,0

Standard version: 110 V, protective hose 1,5 m, cable 6 m, CEE connector. Other voltages, hose and cable lengths on request.

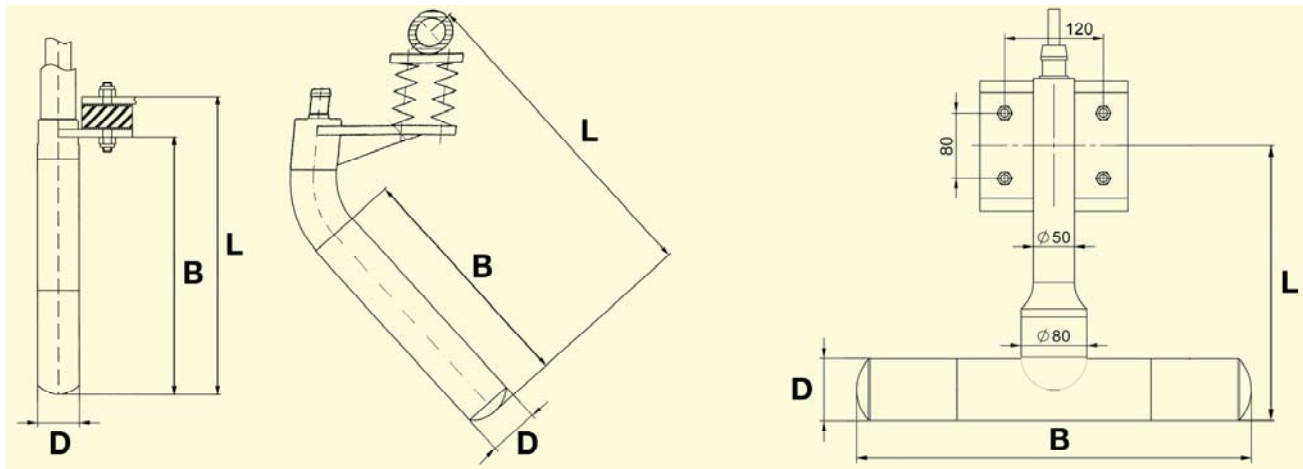

NCX M straight

NCX M elbow shaped

NCX M T horizontal

Applications:

Series NCX M electric internal vibrators are mainly used in concrete slip form pavers. Compared to conventional vibrators the enormously increased centrifugal force permits a higher compaction rate. The resulting optimum removal of entrapped air fulfills the requirements of modern concrete technology.

Design and Function:

The modular design makes these vibrators very easy to service. For mounting standard tools can be used.

The vibrators can be fitted optionally with thermal trips. These will prevent breakdowns from overheating.

The special feature of the NCX M T CC is that it can be operated in both rotational directions using an appropriate control. When the NCX M T CC rotates in one direction, it works with a centrifugal force of 7.2 kN. Upon change of the rotational direction the unbalances shift relative to each other, so that the vibrator works with a centrifugal force of only 5.6 kN.

Nominal voltage / Nominal frequency:

110 V, 200 Hz

NetterVibration supplies the suitable accessories for mounting, installation, control and monitoring of vibrators and impactors.

Netter provides solutions.

Consult our experienced application technicians.

Netter GmbH

Germany

Fritz-Ullmann-Str. 9
55252 Mainz-Kastel
Tel. +49 6134 2901-0

Poland

Al. W. Korfantego 195/17
40-153 Katowice
Tel. +48 32 2050947

Switzerland

Erlenweg 4
4310 Rheinfelden
Tel. +41 61 8316200

Spain

Errota Kalea 8
20150 Villabona-Guipúzcoa
Tel. +34 943 694 994

www.**NetterVibration.com**
info@**NetterVibration.com**



Netter Pneumatic Internal Vibrators Series NVL

- High centrifugal forces
- Adjustable speed
- Low weight
- High operating reliability due to simple and rigid construction
- No bearings, therefore scarcely any wear

The Netter pneumatic internal vibrators series NVL have a high performance level and an extremely rigid construction. They have only two mobile parts, rotor and lamella.

Type NVL		25	35	45	55	75	86	115S*	140S*
Head - Ø	[mm]	25	35	45	55	75	87	115	140
Head length	[mm]	254	270	321	353	398	415	425	520
Frequency	[min ⁻¹]	21.000	18.000	18.000	17.500	16.000	14.000	11.000	9.000
Centrifugal force	[N]	653	1.665	3.200	6.602	14.016	17.750	24.200	34.300
Air consumption	[l/min]	360	450	640	850	1.200	1.400	1.600	2.500
Weight	[kg]	2,3	5,5	5,3	7,3	12,5	17,3	23,0	36,0
Influenced zone - Ø	[mm]	340	400	500	760	1.000	1.100	2.400	3.000

* NVL115S and NVL140S with separate high efficiency oiler.

technical data established at 6 bar.



31

Netter Electronic Frequency Converters Series NFC



- Strong output power
- Considerably lower weight compared to rotating converters
- Considerably lower noise level compared to rotating converters
- Up to 3 connections possible
- Suitable for harsh construction site operation
- Switch off at overload and immediate restart
- Phase control - protection of high frequency internal vibrators
- High safety due to galvanic separated output
- Short time overload capacity up to 150 %
- Suitable for operating with Netter electric internal vibrators series NCX and NCZ



NFC 2,0/1



NFC 3,0/2



NFC 5,5/3



NetterVibration



Netter Electronic Frequency Converters Series NFC

Type	Primary		Secondary		Nominal power [kVA]	Quantity of sockets	Weight [kg]
	Voltage at 50/60 Hz [V]	Current [A]	Voltage at 200 Hz [V]	Current at 42 V [A]			
NFC 2,0/1	1 × 230~	9	3 × 42	27	2	1	20
NFC 3,0/2	1 × 230~	13,5	3 × 42	41	3	2	25
NFC 5,5/3	3 × 400	8,5	3 × 42	76	5,5	3	40

Connection of Netter internal vibrators:

NFC 2,0/1	NFC 3,0/2	NFC 5,5/3
1 x NCZ 480 or	1 x NCZ 660 or	2 x NCZ 660 or
1 x NCX 480 or	1 x NCX 660K or	2 x NCX 660K or
1 x NCZ 370 or	1 x NCZ 560 and 1 x NCZ 370 or	3 x NCZ 560 or
1 x NCX 380	1 x NCZ 560 and 1 x NCX 380 or	3 x NCX 580L or
	1 x NCX 580L and 1 x NCZ 370 or	3 x NCZ 480 or
	1 x NCX 580L and 1 x NCX 380 or	3 x NCX 480 or
	2 x NCZ 480 or	3 x NCZ 370 or
	1 x NCZ 480 and 1 x NCZ 370 or	3 x NCX 380
	1 x NCZ 480 and 1 x NCX 380 or	
	2 x NCX 480 or	
	1 x NCX 480 and 1 x NCZ 370 or	
	1 x NCX 480 and 1 x NCX 380 or	
	1 x NCZ 370 and 1 x NCX 380	

Dimensions:

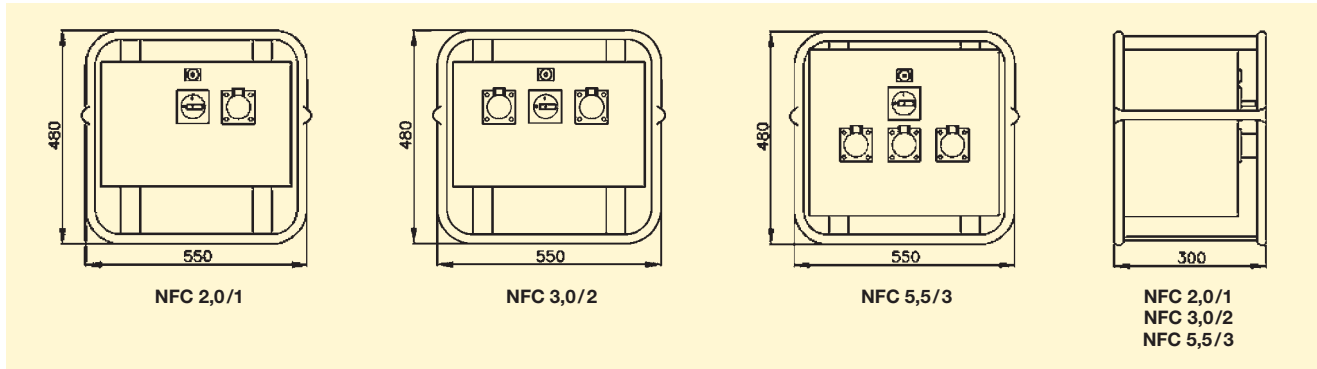

Applications

Frequency converters series NFC are suitable for the power supply of Netter internal vibrators series NCZ, NCZ/S, NCX and NCX/S. It is possible to connect units of other well-known manufacturer.

Technical characteristics

NFC are equipped with the maximum possible quantity of CEE (42 V/32 A) sockets. The voltage is electronically adjusted to the connected vibrators. The steel plate body is pulverized and fixed in a portable protection frame.

Protection

The converters are self-protected against overload, overheating, short-circuit and ground fault in the motor lines.

Permissible operating conditions

Connecting values:

NFC 2,0/1 and NFC 3,0/2: primary 230 V, 50/60 Hz, secondary 42 V, 200 Hz.
NFC 5,5/3: primary 400 V, 50/60 Hz, secondary 42 V, 200 Hz.

Ambient temperature:

0°C to 40°C

Power supply cable:

Length 2 m

Protection:

IP 44

NetterVibration offers suitable frequency converters for all electric internal vibrators.

Netter provides solutions.

Consult our experienced application technicians.

Netter GmbH

Germany

Fritz-Ullmann-Str. 9
55252 Mainz-Kastel
Tel. +49 6134 2901-0

Poland

Al. W. Korfantego 195/17
40-153 Katowice
Tel. +48 32 2050947

Switzerland

Erlenweg 4
4310 Rheinfelden
Tel. +41 61 8316200

Spain

Errota Kalea 8
20150 Villabona-Guipúzcoa
Tel. +34 943 694 994

www.NetterVibration.com
info@NetterVibration.com



33

Netter Frequency and Voltage Converters Series FSW



- Robust and approved design
- Performance suitable to sites
- Long lifetime
- IP 54 isolation specification F
- Primary: 400 V, 50 Hz
- Secondary: optional 42 V, 200 Hz or 250 V, 200 Hz
- Two-wheel cart from FSW 7,5





NetterVibration



Netter Frequency and Voltage Converters Series FSW

Techn. Data	FSW 3	FSW 4	FSW 5,5	FSW 7,5	FSW 11	FSW 15	FSW 20	FSW 25	FSW 30	FSW 45
Primary	Voltage at 50/60 Hz [V]	400	400	400	400	400	400	400	400	400
	Current [A]	6,1	8,1	10,0	14,0	22,0	28,0	36,0	44,0	69,0
Secondary	Nominal current at 42 V, 200 Hz [A]	41,5	55,0	76,0	105	151,0	207,0	275,0	344,0	619,0
	Nominal current at 250V, 200 Hz [A]	7,00	9,25	12,70	17,50	24,00	32,70	43,50	54,50	69,60
	Nominal power [kVA]	3,0	4,0	5,5	7,5	11,0	15,0	20,0	25,0	30,0
	Quantity of sockets	2	3	3	4**	terminal boxes				
	Weight [kg]*	52	48	58	100	110	190	205	230	240
										330

*Weight without protection frame or two-wheel cart **optional with terminal box

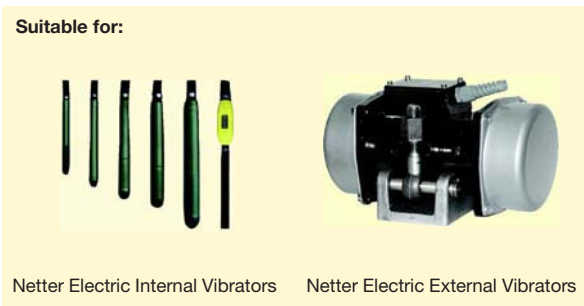
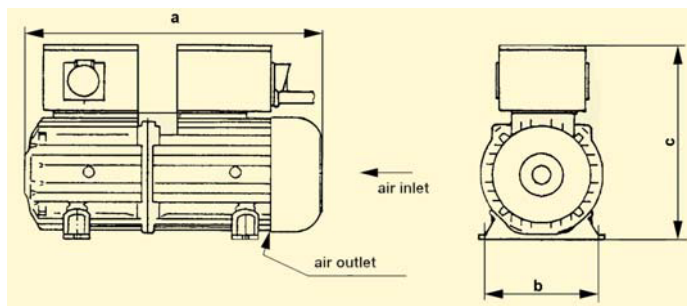

Dimensions in mm	FSW 3	FSW 4	FSW 5,5	FSW 7,5	FSW 11	FSW 15	FSW 20	FSW 25	FSW 30	FSW 45
a	507	501	555	555	844	1058	1058	1058	1058	1252
b	196	251	251	251	256	310	310	310	310	340
c	342	420	420	420	360	416	416	416	416	463

Possible connections*	FSW 3	FSW 4	FSW 5,5	FSW 7,5	FSW 11	FSW 15	FSW 20	FSW 25	FSW 30	FSW 45
NCZ 300	5	6	9	12	18	-	-	-	-	-
NCZ 370	5	6	9	12	18	-	-	-	-	-
NCZ 480	3	3	5	6	10	-	-	-	-	-
NCZ 560	1	2	3	4	6	-	-	-	-	-
NCZ 560 L	1	2	3	4	7	-	-	-	-	-
NCZ 660	1	2	3	3	5	-	-	-	-	-
NCZ 800	-	1	2	2	4	-	-	-	-	-
NEG/NEH 756	4	6	8	11	16	23	30	38	45	68
NEG/NEH 1206	3	4	6	8	11	16	21	26	32	48
NEG/NEH 1606	3	4	5	7	10	14	19	24	29	44

* Designed for simultaneous operation of the indicated number of vibrators.

Applications

Netter series FSW frequency and voltage converters convert the local main voltage into protection voltage.

They are particularly suitable for the operation of Netter internal vibrators series NCZ, NCZ/S, NCX and NCX/S as well as external vibrators series NEG/NEH.

The frequency and voltage converters are available with 42 V or 250 V secondary voltage. FSW converters are equipped with the maximum possible number of CEE (32 A) power sockets.

The required power performance is determined by the internal vibrators to be connected.

A thermal motor protection switch shuts the unit off when current consumption levels are too high.

Safety

Personal safety is assured by means of galvanic isolation.

Permissible operating conditions

Connecting values:
FSW 2 to FSW 45: primary 400 V, 50 Hz, secondary 42 V, 200 Hz

Ambient temperature:

0°C to 40°C.

Netter provides solutions.

Consult our experienced application technicians.

Netter GmbH

Germany
Fritz-Ullmann-Str. 9
55252 Mainz-Kastel
Tel. +49 6134 2901-0

Poland
Al. W. Korfantego 195/17
40-153 Katowice
Tel. +48 32 2050947

Switzerland
Erlenweg 4
4310 Rheinfelden
Tel. +41 61 8316200

Spain
Errota Kalea 8
20150 Villabona-Guipúzcoa
Tel. +34 943 694 994

www.NetterVibration.com
info@NetterVibration.com



34

Netter Diesel Generators Series NFG



- Robust and approved design
- Version suitable to sites
- Long lifetime
- Protection IP 55
- Secondary: optional 42 V, 200 Hz or 250 V, 200 Hz
- Two-wheel carts available



NCZ



NEG / NEH



NFG



NetterVibration



Netter Diesel Generators Series NFG

Type	Primary		Secondary		Nominal current [kVA]	Quantity of sockets	Weight	
	Frequency [min ⁻¹]	Power [kW]	42 V 200 Hz [A]	250 V 200 Hz [A]			without cart [kg]	with cart [kg]
NFG 30 HD	3.000	4,4	45,5	7,00	3,0	2	88	115
NFG 40 HD	3.000	5,2	55,0	9,25	4,0	3	88	115
NFG 55 HD	3.000	7,5	76,0	12,70	5,5	3	113	140
NFG 75 HD	3.000	8,0	103,0	17,50	7,5	4*	120	147

*optional with terminal box

Type with cart	Length [m]	Width [m]	Height [m]
NFG 30 HD	1,30	0,70	1,00
NFG 40 HD			
NFG 55 HD			
NFG 75 HD			

Connection possibilities*	NFG 30 HD	NFG 40 HD	NFG 55 HD	NFG 75 HD
NCZ 300	5	6	9	12
NCZ 370	5	6	9	12
NCZ 480	3	3	5	6
NCZ 560	1	2	3	4
NCZ 560 L	1	2	3	4
NCZ 660	1	2	3	3
NCZ 800	-	1	2	2
NEG/NEH 756	4	6	8	11
NEG/NEH 1206	3	4	6	8
NEG/NEH 1606	3	4	5	7

*laid-out for simultaneous operation of indicated quantity of vibrators.

Suitable for:



Netter electric internal vibrators

Netter electric external vibrators

Applications:

Netter diesel generators series NFG are used to operate Netter electric internal and external vibrators on sites with no electric supply network.

The converter is coupled directly on the Hatz diesel generator. Secondary current voltage optionally in 42 V or 250 V available.

Netter frequency and voltage converters series FSW (leaflet 33) are to be used on sites where electric supply network is available.

Both series are suitable for the operation of Netter electric internal vibrators series NCZ, NCZ/S, NCX and NCX/S or electric external vibrators of the series NEG/NEG.

Permissible operating conditions

Connecting values:

Secondary 42 V, 200 Hz or 250 V, 200 Hz

Ambient temperature:

0°C to 40°C.

Netter provides solutions.

Consult our experienced application technicians.

Netter GmbH

Germany

Fritz-Ullmann-Str. 9
55252 Mainz-Kastel
Tel. +49 6134 2901-0

Poland

Al. W. Korfantego 195/17
40-153 Katowice
Tel. +48 32 2050947

Switzerland

Erlenweg 4
4310 Rheinfelden
Tel. +41 61 8316200

Spain

Errota Kalea 8
20150 Villabona-Guipúzcoa
Tel. +34 943 694 994

www.NetterVibration.com
info@NetterVibration.com



Netter Electric External Vibrators Series NEG/NEA/NED



- Circular vibration
- Nominal frequency from 750 min⁻¹ to 3.600 min⁻¹
- Centrifugal force from 40 N to 217.731 N
- Smooth housing surface
- Stainless steel weight covers
- Ex II 2 GD (ATEX) available
- Protection IP 66-7, Insulation class F
- Stainless steel versions available





NetterVibration

Unbalance type XL Unbalance type XM Unbalance type XS



Netter Electric External Vibrators
 Series NEG 3-Phase
 Series NEA Single Phase
 Series NED Direct Current

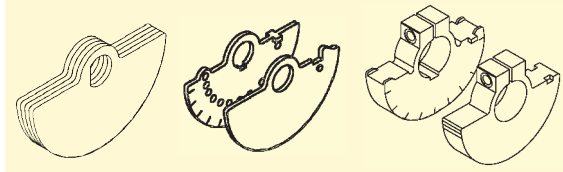

min ⁻¹	Type	Housing		Unbalance		Centrifugal Force		EE _x e II **	Power Input				Nominal Current							
		Size	Material	[cmkg]		[N]			[kW]								[A]			
				NEG/NEA		NEG/NEA			NEG/NEA		NEG		NEA		NEG		NEA			
				50 Hz	60 Hz	50 Hz	60 Hz		50/60 Hz	50 Hz 400 V	60 Hz 480 V	50 Hz 230 V	60 Hz 115 V	50 Hz 400 V	60 Hz 480 V	50 Hz 230 V	60 Hz 115 V			
3000 3600	NEA 504*	50	Al	0,08	0,08	40	57	-	-	-	0,024	0,024	-	-	0,13	0,30				
	NEG/NEA 5020*	60	Al	0,39	0,39	192	277	-	0,035	0,035	0,035	0,035	0,15	0,15	0,17	0,42				
	NEG/NEA 5050*			0,91	0,91	450	647	-	0,045	0,045	0,045	0,045	0,16	0,16	0,20	0,46				
	NEG/NEA 5060	100	Al	1,272	1,272	627	904	-	0,12	0,12	0,11	0,11	0,27	0,23	0,56	1,52				
	NEG/NEA 50120	101	Al	2,4	2,4	1.185	1.708	-	0,18	0,18	0,165	0,165	0,35	0,30	0,75	1,52				
	NEG/NEA 50200			4,2	3,0	2.073	2.133	-	-	-	-	-	-	-	-	-	-			
	NEG/NEA 50300	110	Al	6,02	4,08	2.972	2.900	T3,T4	0,26	0,27	0,28	0,28	0,60	0,50	1,25	2,40				
	NEG/NEA 50550	120	Al	9,99	6,48	4.930	4.606	T3,T4	0,45	0,50	0,5	0,5	0,80	0,75	2,30	4,50				
	NEG/NEA 50770	130	Al	15,59	10,40	7.695	7.392	T3,T4	0,65	0,685	0,7	0,75	1,10	1,00	3,25	7,00				
NEG 50980 NEG 501140	133	Al	19,8	13,2	9.772	9.382	T3,T4	1	1,2	-	-	1,75	1,75	-	-					
			23,0	16,5	11.352	11.727														
1500 1800	NEG/NEA 2530	101	Al	2,4	2,4	296	426	-	0,085	0,095	0,09	-	0,21	0,20	0,43	-				
	NEG/NEA 2570			6,2	4,2	766	747													
	NEG/NEA 25210	110	Al	16,84	11,76	2.078	2.090	T4	0,17	0,17	0,21	-	0,41	0,40	1,00	-				
	NEG/NEA 25420 NEG/NEA 25540	120	Al	32,64	22,66	4.028	4.027	T3,T4	0,30	0,35	0,24	-	0,60	0,60	1,20	-				
				43,80	32,64	5.405	5.800													
	NEG/NEA 25700	130	Al	57,18	41,89	7.056	7.444	T3,T4	0,525	0,665	0,45	-	0,92	0,98	2,50	-				
NEG 25930	133	Al	75,0	52,0	9.254	9.239	T4	0,55	0,68	-	-	0,95	0,95	-	-					
1000 1200	NEG 1630	110	Al	6,02	6,02	331	476	-	0,12	0,135	-	-	0,30	0,30	-	-				
	NEG 1690			16,84	16,84	924	1.330													
	NEG 16190	120	Al	32,64	32,64	1.790	2.578	T4	0,185	0,205	-	-	0,50	0,50	-	-				
	NEG 16310	130	Al	57,18	41,89	3.136	3.309	T4	0,35	0,38	-	-	0,72	0,68	-	-				
	NEG 16410 NEG 16500	133	Al	75,0	52,0	4.113	4.106	T4	0,35	0,38	-	-	0,75	0,67	-	-				
				90,7	66,5	4.974	5.251										-	0,42	0,46	-
750 900	NEG 12100	120	Al	32,64	32,64	1.007	1.450	T3	0,23	0,25	-	-	0,85	0,76	-	-				
	NEG 12180	130	Al	56,8	56,8	1.752	2.523	T3	0,35	0,38	-	-	1,10	1,05	-	-				
	NEG 12230	133	Al	75,0	75,0	2.314	3.332	T4	0,28	0,30	-	-	0,60	0,68	-	-				
3000	NED 50100	102	Al	2,39		1.180		-	0,10 (12 V =)		0,10 (24 V =)		8 (12 V =)		4 (24 V =)					
	NED 50200	103	Al	4,21		2.080		-	0,19 (12 V =)		0,19 (24 V =)		16 (12 V =)		8 (24 V =)					
	NED 50500	122	Al	9,98		4.930		-	0,27		0,27		22,5		11,3					
3600	NED 601110	133	Al	15,6		11.087		-	0,53 (24 V =)				22 (24 V =)							

*Protection IP 65, **Technical data available upon request



NetterVibration



Netter Electric External Vibrators Series NEG 3-Phase

Unbalance type XLs

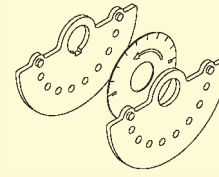

Unbalance type XS

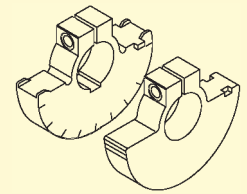

min ⁻¹	Type	Housing		Unbalance		Centrifugal Force		EEx e II *	Power Input		Nominal Current		Weight		
		Size	Material	[cmkg]		[N]			50/60 Hz	[kW]		[A]		[kg]	
				50 Hz	60 Hz	50 Hz	60 Hz			50 Hz 400 V	60 Hz 480 V	50 Hz 400 V	60 Hz 480 V	50 Hz	60 Hz
3000 6000	NEG 501540	140	AL	30,6	20,4	15.103	14.499	T3, T4	1,4	1,45	2,3	2,0	34,3	32,8	
	NEG 501800			35,8	25,6	17.669	18.195		T3	2,0	2,0	3,3	2,9	35,1	33,6
	NEG 502020	150	GGG	41,0	25,6	20.236	18.195	T3	2,2	2,2	3,5	3,0	49	47	
	NEG 502270			46,0	30,6	22.704	21.748		T3	2,2	2,2	3,5	3,0	50	49
	NEG 503400			65,6	43,7	32.364	31.052		-	3,8	3,8	6,2	5,4	106	102
	NEG 503820	170	GGG	76,5	54,6	37.764	38.827	-	4,0	4,0	6,5	5,6	107	103	
	NEG 506220			126,0	88,6	62.189	62.970		-	5,5	5,5	9,2	8,0	188	181
NEG 508830	190	GGG	179,0	123,8	88.347	87.988	-	10,0	9,3	18,0	13,0	215	210		
1500 1800	NEG 251410	140	AL	112	80,0	13.820	14.215	T3, T4	0,9	1,05	1,45	1,5	44,8	41,8	
	NEG 251800			142,8	97,0	17.620	17.235		-	1,1	1,2	2,0	1,9	49,3	45,3
	NEG 252060	160	AL	163	112,4	20.113	19.971	-	1,35	1,45	2,5	2,3	54	52	
	NEG 252370			192,4	134,8	23.740	23.951		T3, T4	1,6	1,7	3,2	3,0	75	69
	NEG 253050			247,0	171,6	30.477	30.490		-	1,9	2,0	3,8	3,5	82	79
	NEG 253720	170	GGG	301,6	206,7	37.214	36.726	T3, T4	2,2	2,5	3,9	3,9	127	122	
	NEG 254310			349,2	234,7	43.088	41.702		-	2,5	2,8	4,8	4,65	125	120
	NEG 254900	180	GGG	396,8	272,8	48.961	48.472	T3	3,6	3,4	6,0	5,0	174	166	
	NEG 256460	190	GGG	523,8	364,6	64.632	64.783	-	6,0	6,0	10,5	9,0	212	200	
	NEG 258040	195	GGG	652,0	452,0	80.450	80.312	-	7,0	8,0	11,6	11,5	225	210	
	NEG 258260	197	GGG	669,2	492,4	82.573	87.490	-	7,5	8,5	12,2	12,0	317	303	
	NEG 2511210	200	GGG	908,8	633,2	112.137	112.508	-	10,0	10,5	17,5	15,5	433	411	
	NEG 2513850			1.122,8	825,2	138.542	145.981		-	11,0	12,0	20,0	20,0	458	424
	1000 1200	NEG 16810	140	AL	144,2	111,8	7.908	8.829	T3, T4	0,68	0,76	1,4	1,4	46	41
NEG 161130		202,0			142,8	11.078	11.277	-		0,75	0,75	1,7	1,5	57	48
NEG 161420		254,2			187,4	13.940	14.799	-		0,95	1,0	1,8	1,7	65	58
NEG 161610		160	AL	292,8	192,4	16.057	15.194	T3, T4	1,1	1,3	2,2	2,2	80	76	
NEG 162110				385,4	263,6	21.135	20.816		-	1,5	1,77	3,0	2,8	95	83
NEG 162550		170	GGG	464,2	323,0	25.457	25.507	T3	1,96	2,1	4,1	3,75	140	127	
NEG 163030				553,4	400,0	30.348	31.588		-	2,2	2,4	4,5	4,3	156	141
NEG 163820		180	GGG	696,4	467,4	38.191	38.253	T3, T4	2,5	3,0	5,1	5,0	200	182	
NEG 164700				857,0	587,4	46.998	46.387		-	3,2	3,6	6,5	6,0	219	198
NEG 165190		190	GGG	946,4	658,4	51.901	51.994	T3	3,8	4,0	7,0	6,5	247	225	
NEG 165580				1.008,8	706,2	54.560	55.768		-	3,8	3,9	7,0	7,1	240	245
NEG 166270				1.142,8	795,0	62.671	62.781		-	4,3	5,0	8,2	8,1	279	251
NEG 166670		197	GGG	1.216,6	795,8	66.718	62.844	-	5,0	5,9	10,0	9,8	285	257	
NEG 167890		195	GGG	1.439,4	993,4	78.937	78.448	-	7,0	7,5	9,6	13,0	320	282	
NEG 168500				1.550,4	1.077,0	85.024	85.050		-	7,5	8,2	14,0	12,9	326	289
NEG 169510		197	GGG	1.734,6	1.132,8	95.125	89.457	-	7,6	8,0	13,5	12,4	381	340	
NEG 1612060		200	GGG	2.199,2	1.508,6	120.604	119.134	-	9,0	9,5	16,3	15,0	500	445	
NEG 1613890		205	GGG	2.532,4	1.740,0	138.877	137.407	-	10,6	11,3	19,0	18,0	643	605	
NEG 1617000				3.100,0	2.087,8	170.004	164.873		-	13,0	13,7	24,5	23,0	705	656
750 900		NEG 12460	140	AL	144,4	142,2	4.454	6.317	T3	0,4	0,45	1,2	1,2	46	46
	NEG 12640	202,0			195,6	6.231	8.689	T3, T4			0,5	1,4	1,3	57	57
	NEG 12900	160	AL	292,8	292,8	9.032	13.006	T3	0,95	1,1	2,2	2,2	80	80	
	NEG 121430	170	GGG	464,2	464,2	14.319	20.620	T3	1,5	1,79	4,1	4,2	133	133	
	NEG 122150			696,4	696,4	21.482	30.934		T3	2,0	2,3	5,4	5,2	201	201
	NEG 122640	180	GGG	857,0	857,0	26.436	38.068	-	2,5	3,0	6,0	6,0	217	217	
	NEG 122920			964,4	964,4	29.194	42.839		T3	2,8	3,35	6,5	6,5	242	242
	NEG 123530	190	GGG	1.142,8	1.142,8	35.253	50.764	T3	4,0	4,3	8,2	7,85	267	267	
	NEG 124440	195	GGG	1.439,4	1.439,4	44.402	63.939	-	4,9	5,8	9,9	9,5	320	320	
	NEG 127640	197	GGG	2.478,0	2.194,6	76.440	97.485	-	6,8	7,5	13,2	12,0	438	419	
	NEG 128520	200	GGG	2.763,2	2.481,4	85.238	110.225	-	7,6	8,3	14,0	13,5	540	520	
	NEG 1211070	205	GGG	3.589,2	3.100,0	110.718	137.703	-	9,2	9,6	21,0	19,5	702	680	
	NEG 1213160			4.267,4	3.812,8	131.639	169.366		-	10,4	11,2	22,0	20,0	755	711
	NEG 1217670	210	GGG	5.726,6	4.901,6	176.651	217.731	-	12,5	16,2	26,5	28,0	1.015	981	

*Technical data available upon request

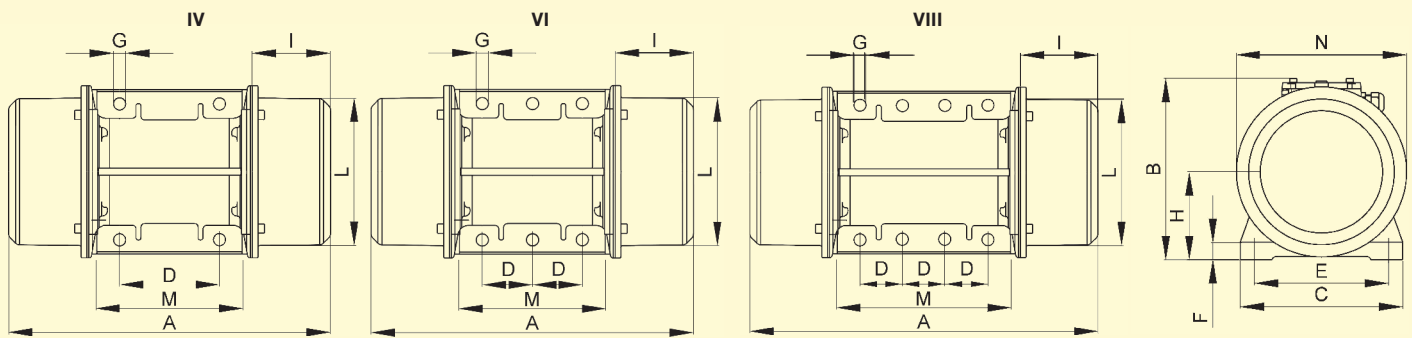

Type	Type of Housing NEG	Dimensions [mm]													Unbalance [No. of Unbalance Discs]	
		A 50/60 Hz	B	C	D	E	n ₂ Befestigungsmaße	F	G	H	I 50/60 Hz	L	M	N	Type	50/60 Hz
NEG 501540	IV	438	257	230	140	190	4	25	17	124,5	103	201	224	241	XLs	12/8
NEG 501800		14/10														
NEG 502020	IV	463	235	230	140	190	4	22	17	104	104	188	248	224	XLs	16/10
NEG 502270																18/12
NEG 503400	IV	590	335	310	155	255	4	30	23,5	160	140	274	302	310	XLs	12/8
NEG 503820																14/10
NEG 506220	IV	670	380	390	200	320	4	32	28	189	155	340	360	384	XS	4
NEG 508830	IV	629	395	392	200	320	4	100	28	192	134,5	358	270	375	XS	4
NEG 251410	IV	438	257	230	140	190	4	25	17	124,5	103	201	224	241	XS	4
NEG 251800		490														
NEG 252060		560														
NEG 252370		523														
NEG 253050	IV	600	283	275	155	225	4	28	22	140	130	231	255	271	XS	4
NEG 253720		670/588														
NEG 254310	IV	670/588	335	310	155	255	4	30	23,5	160	139	274	302	310	XS	4
NEG 254900	IV	640	369	340	180	280	4	30	26	173	155	301	322	336	XS	4
NEG 256460	IV	670	380	390	200	320	4	32	28	189	155	340	360	384	XS	4
NEG 258040	IV	624	402	392	200	320	4	35	28	199,5	132	358	352	402	XS	4
NEG 258260	VI	862	434,5	460	125	380	6	35	38	215	230	379	392	439	XS	4
NEG 2511210	VI	990	454	530	140	440	6	38	44	230	240	423	510	448	XS	4
NEG 2513850																
NEG 16810	IV	490/438	257	230	140	190	4	25	17	124,5	129/103	201	224	241	XS	4
NEG 161130		560														
NEG 161420																
NEG 161610	IV	600/523	283	275	155	225	4	28	22	140	168,5/130	231	255	271	XS	4
NEG 162110		655/600									196/168,5					
NEG 162550	IV	670/610	335	310	155	255	4	30	23,5	160	180/150	274	302	310	XS	4
NEG 163030		710									200					
NEG 163820	IV	742	369	340	180	280	4	30	26	173	206	301	322	336	XS	4
NEG 164700		802									236					
NEG 165190	IV	772	380	390	200	320	4	32	28	189	206	340	360	384	XS	4
NEG 165580		836									238	334	352			
NEG 166270		850									245	340	360			
NEG 166670		VI									750	434,5	460			
NEG 167890	IV	854	402	392	200	320	4	35	28	199,5	247	358	352	402	XS	4
NEG 168500																
NEG 169510	VI	862	434,5	460	125	380	6	35	39	215	230	379	392	439	XS	4
NEG 1612060	VI	990	454	530	140	440	6	38	44	230	240	423	510	448	XS	4
NEG 1613890	VIII	960	526	570	140	480	8	41	45	268	200	488	560	516	XS	4
NEG 1617000		1.040									240					
NEG 12460	IV	490	257	230	140	190	4	25	17	124,5	129	201	224	241	XS	4
NEG 12640		560									164					
NEG 12900	IV	600	283	275	155	225	4	28	22	140	168,5	231	255	271	XS	4
NEG 121430	IV	670	335	310	155	255	4	30	23,5	160	180	274	302	310	XS	4
NEG 122150	IV	742	369	340	180	280	4	30	26	173	206	301	322	336	XS	4
NEG 122640		802									236					
NEG 122920	IV	772	380	390	200	320	4	32	28	189	206	340	360	384	XS	4
NEG 123530		850									245					
NEG 124440	IV	854	402	392	200	320	4	35	28	199,5	247	358	352	402	XS	4
NEG 127640	VI	1.002	434,5	460	125	380	6	35	39	215	300	379	392	439	XS	4
NEG 128520	VI	1.070	454	530	140	440	6	38	44	230	280	423	510	448	XS	4
NEG 1211070	VIII	1.040	526	570	140	480	8	41	45	268	240	488	560	516	XS	4
NEG 1213160		1.120									280					
NEG 1217670	VIII	1.150	607	610	140	520	8	38	45	297	280	542	510	582	XS	4



Netter Electric External Vibrators Series NEG

Special Version with Reduced Duty Time

Applications

Series NEG electric external vibrators are designed for continuous operation with 100% duty time. In addition, special versions with reduced duty times are available. The reduced duty time allows the use of smaller units possible with the same power output.

Design and functioning principle

Special vibrators with larger unbalances can be used for intermittent or short-time operation. Despite smaller unit size they deliver the same centrifugal forces as the next housing size up.

NEG with reduced duty times are built according to the customer's requirements, to enable individual solutions.

Special Version with CC Unbalances

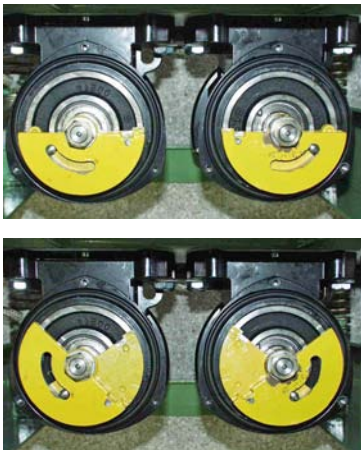

Applications

The special version with CC unbalances are used when two different unbalance settings need to be available during operation.

Design and functioning principle

In order to use the CC unbalances, a suitable electric switching circuit is required so that the NEG can be operated in both directions. When the NEG rotates in one direction it operates with e.g. maximum unbalance (top picture).

When the direction of rotation changes, the outer unbalance disc automatically turns through a specified angle against the inner unbalance disc, creating a reduced unbalance setting (picture below).

The CC unbalances are built according to the customer's requirements and allow a second unbalance setting of 25-100% of the main value.

Special Version NEG S in Stainless Steel



Applications

Series NEG S electric external vibrators can be used wherever the surfaces are subject to particular requirements for chemical resistance. An important feature of the NEG S series is its modular construction. This enables economical production of even the smallest of series in various steel materials. The protection class IP 66 (protection from dust entry and water flooding) allows cleaning with power jets and aggressive cleaning agents.

Design and functioning principle

All internal components of the stainless steel vibrators come from the established NEG series and are thus production proved.

Even the standard version of the NEG S has a surface quality of 6,3 µm and therefore satisfies the requirements for the chemical and pharmaceutical industries. A higher surface quality can easily be provided if required, e.g. for the food industry. Stainless steel housings are generally heavier than the standard housings. The greater mass must therefore be considered in the layout stage.

Static Adjustable Frequency Converter Series NFI/NFU Static Adjustable Frequency Control Series SRF

Applications

The frequency control of the series SRF and the frequency converters of the series NFI and NFU are used for speed regulation of electric vibrators.

Special applications require frequencies which cannot be achieved with normal multipole vibrators at line frequency. These frequency converters are characterized by their robust and straight-forward design.

Design and Functioning Principle

Low-loss power electronics permit the operation at input voltages with high tolerances. The frequency converters generate three-phase voltages with variable frequencies of 0 Hz to 500 Hz, thus making it possible to easily adjust the speed. The permissible temperature range is 0°C to +40°C.

All required parameters such as starting and stopping time, run-up ramp, maximum motor and pulse frequency, slip compensation and U/F characteristic are predefined by **NetterVibration**.

Optionally a brake resistor can be used for time-critical applications or large vibrators which permits a rapid braking / deceleration within a few revolutions after switching off the supply voltage in order to avoid unwanted resonance vibrations.



SRF frequency controls are mounted in a switch cabinet with protection type IP 54.



NFI frequency converters are mounted in an IP 2x housing for installation in a customer existing switch cabinet. The performance data correspond to those of the series SRF.



NFU frequency converters with motor output in the IP 54 housing for wall-mounting are equipped with an on-off switch, direction switch and set point potentiometer.

Type*	Supply Voltage	Max. Motor		Dimensions (W× H× D) [mm]
		Power Input [kW]	Current [A]	
SRF 1-007/4,8	1 ~ 200 ... 240 V 50/60 HZ	0,75	4,8	300 × 400 × 200
SRF 1-011/6,9		1,10	6,9	300 × 400 × 200
SRF 1-022/11		2,20	11,0	400 × 500 × 250
SRF 2-007/2,3	3 ~ 380 ... 415 V 50/60 HZ	0,75	2,3	400 × 500 × 250
SRF 2-015/4,1		1,50	4,1	
SRF 2-022/5,5		2,20	5,5	
SRF 2-040/9,5		4,00	9,5	
SRF 2-055/14,3		5,50	14,3	600 × 600 × 300
SRF 2-075/17		7,50	17,0	
SRF 2-110/27,7		11,00	27,7	
SRF 2-150/33	15,00	33,0		

* Technical data apply also to NFI

Type	Supply Voltage	Max. Motor-Current		Dimensions (W× H× D) [mm]
		Power Input [kW]	Current [A]	
NFU 1-004/3,3	1 ~ 200 ... 240 V 50/60 HZ	0,4	3,3	210 × 240 × 163
NFU 1-007/4,8		0,75	4,8	215 × 297 × 192
NFU 1-011/6,9		1,1	6,9	
NFU 1-015/8		1,5	8,0	
NFU 1-022/11		2,2	11,0	230 × 340 × 208
NFU 2-004/1,5	3 ~ 380 ... 415 V 50/60 HZ	0,4	1,5	215 × 297 × 192
NFU 2-007/2,3		0,75	2,3	
NFU 2-011/3		1,1	3,0	
NFU 2-015/4,1		1,5	4,1	
NFU 2-022/5,5		2,2	5,5	230 × 340 × 208
NFU 2-040/9,5		4,0	9,5	

Netter Braking Devices Series BZ



Type	Supply Voltage	Max. Nominal Power [kW]	Dimensions (W x H x D) [mm]
BZ 30	1 ~ 230 V /	5 / 5,5	55 × 68 × 110
BZ 70	3 – 400 V	10 / 11	158 × 185 × 110
BZ 200	50/60 Hz	26 / 28	145 × 270 × 180

The max. nominal power serves only as a guide for selection. Please consult us, we will help you with your layout!

Applications

Series BZ braking devices are used to bring the running NEG to a standstill as quickly as possible.

It is often necessary to be able to switch off vibrating tables and conveyors without them running on, in order to avoid the symptoms of resonance.

A special feature of these devices is a very high braking efficiency with compact unit size.

Design and functioning principle

Upon activation of the brake the load-resistant power electronics changes the direction of the electric rotational field, thus bringing the NEG to an immediate standstill. The momentarily high braking currents are easily tolerated by the NEG. The permissible temperature range lies between 0°C and +40°C.

These braking devices are only suitable for constant mains frequencies of 50 Hz or 60 Hz. Operation together with a frequency converter is not permitted.



Netter Electric External Vibrators Series NEG

Formulas

Unbalance	$M = s \times m$	Centrifugal force	$F = a_{(g)} \times m \times 9,81$
Acceleration	$a_{(g)} = s \times \left(\frac{n}{1000}\right)^2 \times 5,59$	Centrifugal force	$F = M \times \left(\frac{n}{1000}\right)^2 \times 54,84$

Symbols and Units

s	Amplitude	cm	n	Frequency	min ⁻¹
m	Weight with vibrator	kg	M	Unbalance	cmkg
F	Centrifugal force	N	a _(g)	Acceleration	g

Which Kind of Vibrator for Which Kind of Duty?

Duty	Frequency	Acceleration [a _(g)] Times acceleration due to gravity	Amplitude	Vibration	
				Rotary	Linear
Conveying, dosing	750 – 3000	2 – 5	Large		↔
Sieving	1000 – 1500	3 – 4	Large		↔
Draining	1500 – 3000	3 – 5	Medium		↔
Cleaning, shaking off filters	1500 – 3000	2 – 3	Medium	↻	
Lightening, loosening Emptying bulk material	1500 – 3000	0.15 - 0.2 of weight of material in the conical part of the silo	Medium	↻	
Compacting bulk material	1500 – 6000	2 – 4	Small	↻	↔
Concrete compaction	3000 – 9000	0,8 – 1,5	Very small	↻	↔
Testing components	300 – 6600	0,5 – 5	Adjustable	↻	↔



Conveying



Sieving

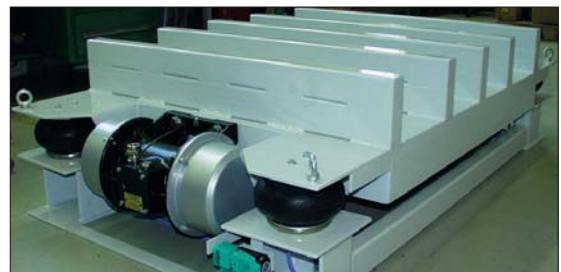

Compacting

Applications

Series NEG, NEA or NED electric external vibrators are used whenever, for example, conveyor chutes or sieves need to be driven. In addition, these devices can loosen material blockages and adhesions in silos. When used on concrete forms, the especially even vibration produces high surface quality and compaction of the concrete.

The special feature of the NEG is its maintenance-free operation, even in rough environmental conditions.

Design and functioning principle

Electric external vibrators are unbalance motors, which work according to the short circuit runner principle and, apart from a few significant differences, are very similar to conventional electric motors.

The 3-phase NEG units run at 750, 1000 or 3000 min⁻¹ with a 230/400V, 50 Hz power supply, depending on the number of poles.

The NEA single phase units run at 3000 min⁻¹ with a 230V, 50 Hz power supply. Additional voltages are available.

The direct current NED units run at 3000 min⁻¹ with a 12 or 24 Volt power supply.

Unbalances sitting on each end of the shaft produce an unidirectional sinus-shaped rotation at the frequency of the respective speed of rotation.

All NEG/NEA are also designed for operation at 60 Hz. The speed of rotation then lies at 20% above the values at 50 Hz. The unbalance is adjusted if necessary.

Generously dimensioned rolling bearings guarantee high operational safety. All NEG are suitable for operation with Netter frequency converters, without limitation.

**Netter provides solutions.
Consult our experienced application technicians.**

Netter GmbH

Germany

Fritz-Ullmann-Str. 9
55252 Mainz-Kastel
Tel. +49 6134 2901-0

Poland

Al. W. Korfantego 195/17
40-153 Katowice
Tel. +48 32 2050947

Switzerland

Erlenweg 4
4310 Rheinfelden
Tel. +41 61 8316200

Spain

Errota Kalea 8
20150 Villabona-Guipúzcoa
Tel. +34 943 694 994

www.NetterVibration.com
info@NetterVibration.com



14



Netter Pneumatic External Vibrators Series NVR, NVG, NVT and NQT

- Circular vibration
- Nominal frequency from 8.500 min⁻¹ to 17.000 min⁻¹
- Centrifugal force from 7.130 N to 62.260 N
- Frequency infinitely variable by air pressure
- No bearings
- Easily and quickly removable
- Noise reduced design NQT



NVG 61



NVR 61



NVT with bracket NVH 4



NetterVibration



Netter Pneumatic External Vibrators Series NVR, NVG, NVT and NQT

Type		NVR [®] , NVG [®]			NVT [®] , NVG [®]		NVT [®] , NVG [®]			NQT	
		49	55	61	82	113	84	87	105	93	108
Nominal frequency	[min ⁻¹]	17.000	16.500	16.000	9.000	8.500	16.000	15.200	14.500	10.000	10.000
Centrifugal force	[N]	7.130	11.000	14.250	15.320	38.830	27.400	37.500	62.260	18.480	24.788
Unbalance	[cmkg]	0,45	0,74	1,02	3,45	9,80	1,95	2,96	5,40	3,37	4,52
Air consumption	[l/min]	1.000	1.100	1.200	1.600	1.700	1.600	1.600	1.800	1.450	1.550
Weight	[kg] ①	6,6	7,0	7,6	14,9	16,9	14,0	14,4	16,3		
without hose	[kg] ②	7,1	7,3	7,8	19,7	22,6	20,0	20,4	22,4		
Weight with hose	[kg]									18,6	20,3

NVG with base plate. NVT and NQT with carrying handle on top for bracket NVH 4. NVR without carrying handle for bracket NVH 1. Data obtained on 6 bar.

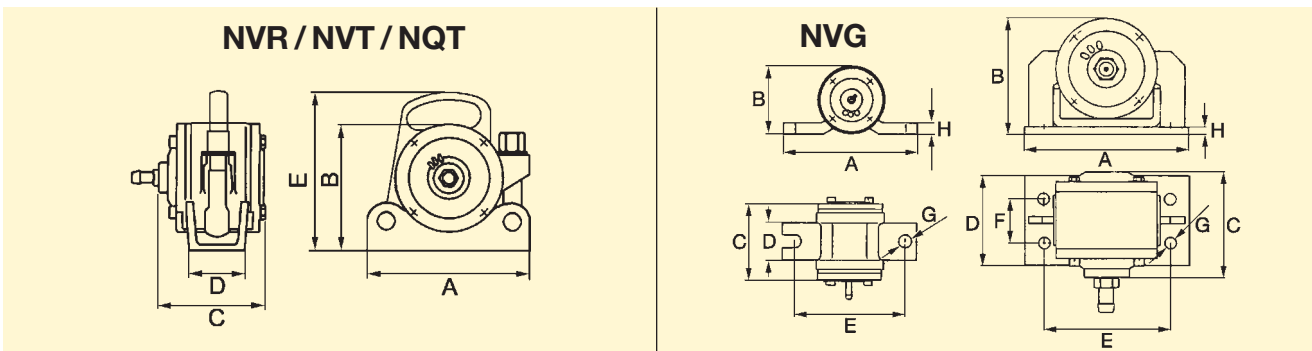

Type	A [mm]	B [mm]	C [mm]	D [mm]	E [mm]	F [mm]	Ø G [mm]	H [mm]
NVG 49, 55, 61	220	111	175	60	180	-	20	20
NVR 49, 55, 61	182	140	175	90	-	-	-	-
NVT 82, 113, 84, 87, 105	240	185	150	83	225	-	-	-
NVG 82, 113, 84, 87, 105	260	187	145	140	200	70	17	12
NQT 93, 108	240	230	240	80	-	-	-	-



Compacting of moulding sand



Tunnel moulds

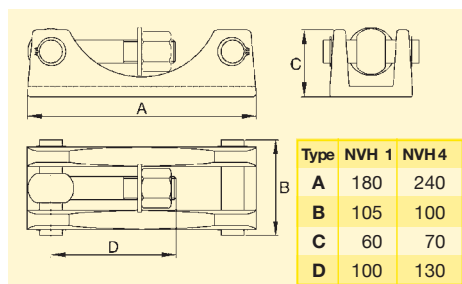

Dimensions of NVH 1 and NVH 4

Application

The pneumatic external vibrators series NQT, NVG, NVR und NVT are especially suitable for compacting, conveying and loosening bulk material.

They are used to compact concrete, empty bins and as drives for conveyors, sieves and vibrating tables.

A special feature is the ruggedness against strong varying loads. There is no danger of overload.

Design and functioning principle

The vibration (circular) is produced by eccentric rotating rotors. The frequency and herewith the centrifugal force are continuously adjustable by the operating pressure. For operation a control valve is required (not included in scope of delivery).

Permissible operating conditions

Drive medium:

Compressed air or nitrogen (Filter ≤ 40 µm), preferably with oil mist.

Operating pressure:

1 bar to 7 bar

Ambient temperature:

-10°C to +60°C

Units for other temperatures are available.

NetterVibration offers the accessories required for the mounting, installation, control and monitoring of vibrators and impactors.

Netter provides solutions.

Consult our experienced application technicians.

Netter GmbH

Germany

Fritz-Ullmann-Str. 9
55252 Mainz-Kastel
Tel. +49 6134 2901-0

Poland

Al. W. Korfańtego 195/17
40-153 Katowice
Tel. +48 32 2050947

Switzerland

Erlenweg 4
4310 Rheinfelden
Tel. +41 61 8316200

Spain

Errota Kalea 8
20150 Villabona-Guipúzcoa
Tel. +34 943 694 994

www.NetterVibration.com
info@NetterVibration.com

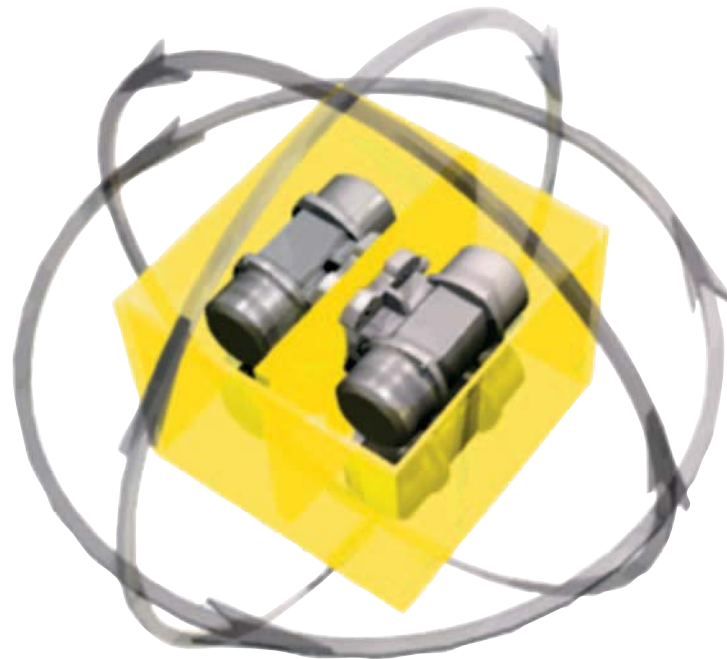

37

Netter Multiple-Shaft Vibration Systems Series *VectorDrive*



- 100% controlled vibration in each direction
- Resonance-free start and stop
- Amplitude adjustment during operation
- Frequency control during operation
- Constant acceleration with varying loads
- Prevention of resonance and associated noise
- Operating times of less than 1 second possible
- Control loops for acceleration possible

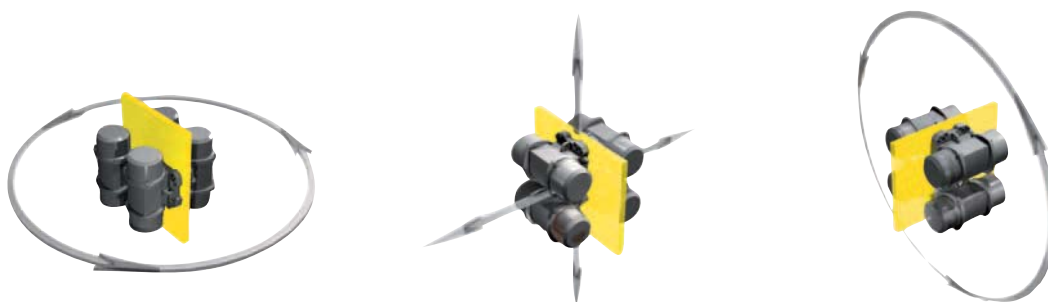



Netter Multiple-Shaft Vibration Systems Series *VectorDrive*

Horizontal arrangement of vibrators

E.g. for mixing, feeding, compacting and rocking

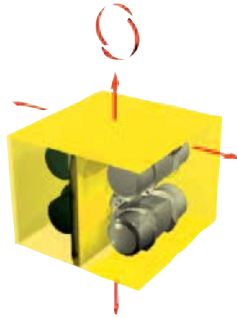

Vertical arrangement of vibrators

E.g. for mixing, tumbling, compacting and sieving

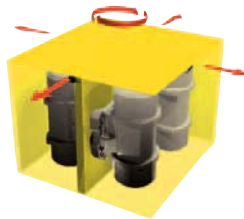

Linear arrangement of vibrators

(compact mounting)

E.g. for feeding, compacting and rocking

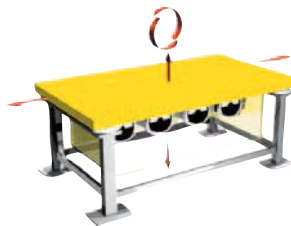

VectorDrive



Visual aging of paving stones

Applications:

The multiple-shaft vibration system **VectorDrive** offers a multitude of application possibilities.

The resonance-free starting and stopping, together with independent regulation of the working direction, frequency and amplitude open up new possibilities for compacting, mixing, feeding and distributing.

Design and Function:

The **VectorDrive** system consists of a control unit and at least 4 vibrators.

For an electric vibrator there are generally two operating conditions and two transitional phases: standstill (no vibration), nominal rotational speed (vibration) and deceleration up to nominal rotational speed or deceleration down to standstill. Often, however, only the two operating conditions, standstill and nominal rotational speed, are desired, since detrimental resonance zones must be passed through in the transitional phases.

Example: Bulk material is optimally compacted using external vibrators at 3000 revs/min. When passing through rotational speeds between 1700 revs/min and 1300 revs/min, undesirable loosening can occur. The best solution would be to simply switch on the vibration at the nominal rotational speed and then switch it off again.

The control unit of the **VectorDrive** system makes this desired "on/off" effect (vibration / no vibration) possible.

Within a fraction of a second, the unbalances are positioned with each other in a way that allows the required centrifugal force and working direction.

Independent of the arrangement of the vibrators on the table, it is possible to create circular vibrations, as well as linear vibrations, by a change of the working direction. The various working directions can be controlled successively during operation, also with changing frequencies and amplitudes.

The **PowerCube** is the preferred variant for the arrangement of the vibrators. The vibrators, in this case, are arranged in a cube under the table. The vibrators can be easily rearranged by dismounting and rotating the cube. Of course, it can just as easily be mounted under a different table construction.

Netter supplies solutions. Consult our experienced application technicians.

Netter GmbH

Germany

Fritz-Ullmann-Str. 9
55252 Mainz-Kastel
Tel. +49 6134 2901-0

Poland

Al. W. Korfantego 195/17
40-153 Katowice
Tel. +48 32 2050947

Switzerland

Erlenweg 4
4310 Rheinfelden
Tel. +41 61 8316200

Spain

Errota Kalea 8
20150 Villabona-Guipúzcoa
Tel. +34 943 694 994

www.NetterVibration.com
info@NetterVibration.com

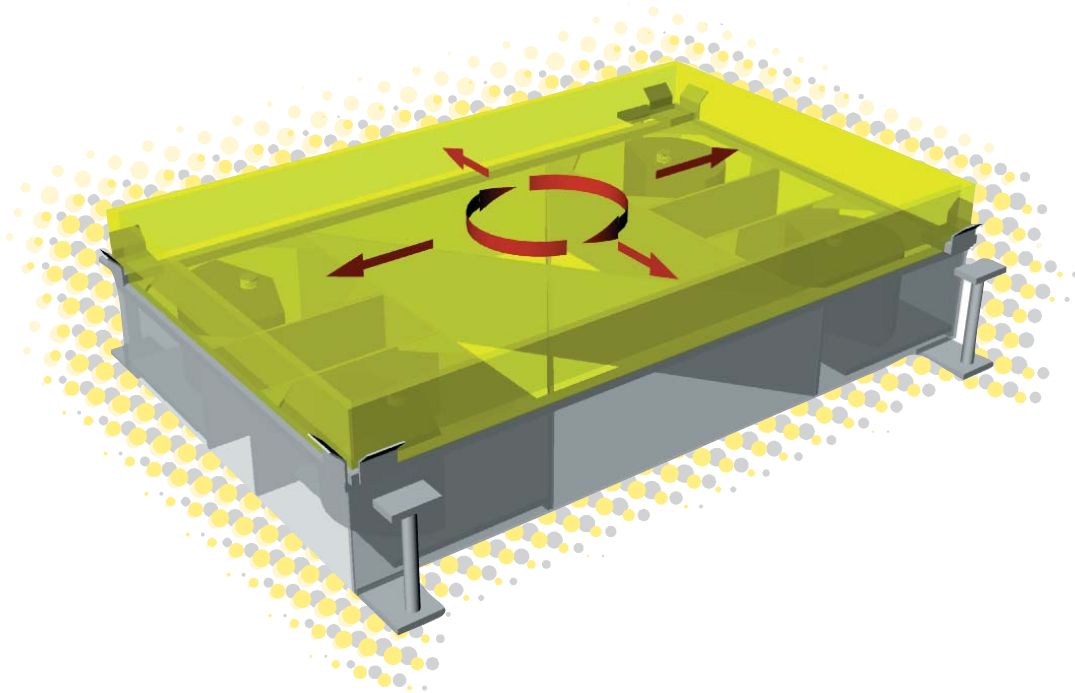

42

Netter Shaker Station for Concrete Compaction Series *GyroShake*

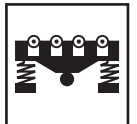

- System for silent compaction, noise level below 70 dB(A)
- Nearly pore-free exposed concrete
- Regulation of amplitude during operation
- Regulation of frequency during operation
- Can be integrated in pallet circulation systems
- Shaker station size as per customer's requirement

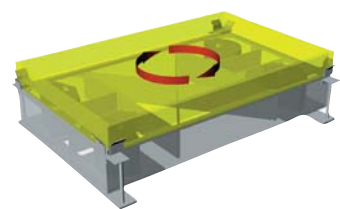
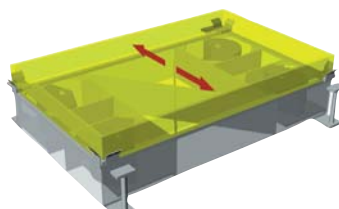
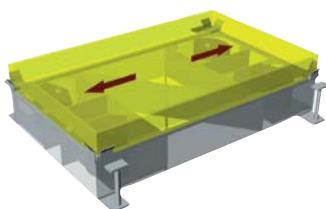



NetterVibration

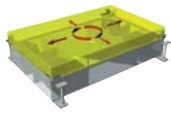

Netter Shaker Station Series *GyroShake*

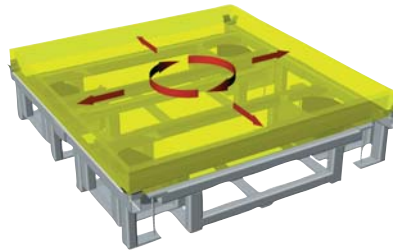
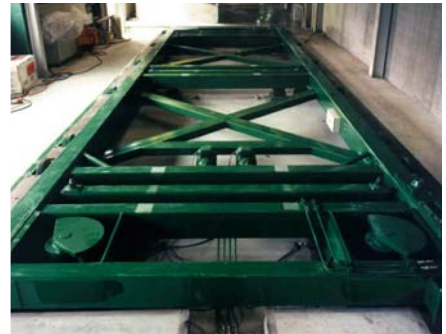

Technical data and dimensions as per customer's requirements.

Applications

Shaker stations in the *GyroShake* series are used for the compaction of concrete in pre-cast part manufacturing plants. The concrete for e.g. panel ceilings, garage floors, double-wall panels or railway sleepers is silently compacted in moulds, with operational noise emission levels of below 70 dB(A).

The system impresses with its high compaction performance, practically pore-free exposed concrete and short cycle times at < 70 dB(A). It can be integrated in pallet circulation systems and controlled by their master computer. The stations are individually assembled to meet the customer's needs.

Design and Working Principle

The station consists of a control and a base frame on which a free-swinging frame is fixed by using a patented suspension system. This guarantees a loss-free, defined deflection of the frame. At least 4 electric unbalance motors are placed on the frame.

The selection of the parameters for the X-, Y- (longitudinal and lateral directions) and an additional circular motion (Z-motion) is made via the electronic control. The unbalance motors can be regulated within a frequency range of 0 –7 Hz.

**Netter provides solutions.
Consult our experienced application technicians.**

Netter GmbH

Germany
Fritz-Ullmann-Str. 9
55252 Mainz-Kastel
Tel. +49 6134 2901-0

Poland
Al. W. Korfantego 195/17
40-153 Katowice
Tel. +48 32 2050947

Switzerland
Erlenweg 4
4310 Rheinfelden
Tel. +41 61 8316200

Spain
Errota Kalea 8
20150 Villabona-Guipúzcoa
Tel. +34 943 694 994
www.NetterVibration.com
info@NetterVibration.com

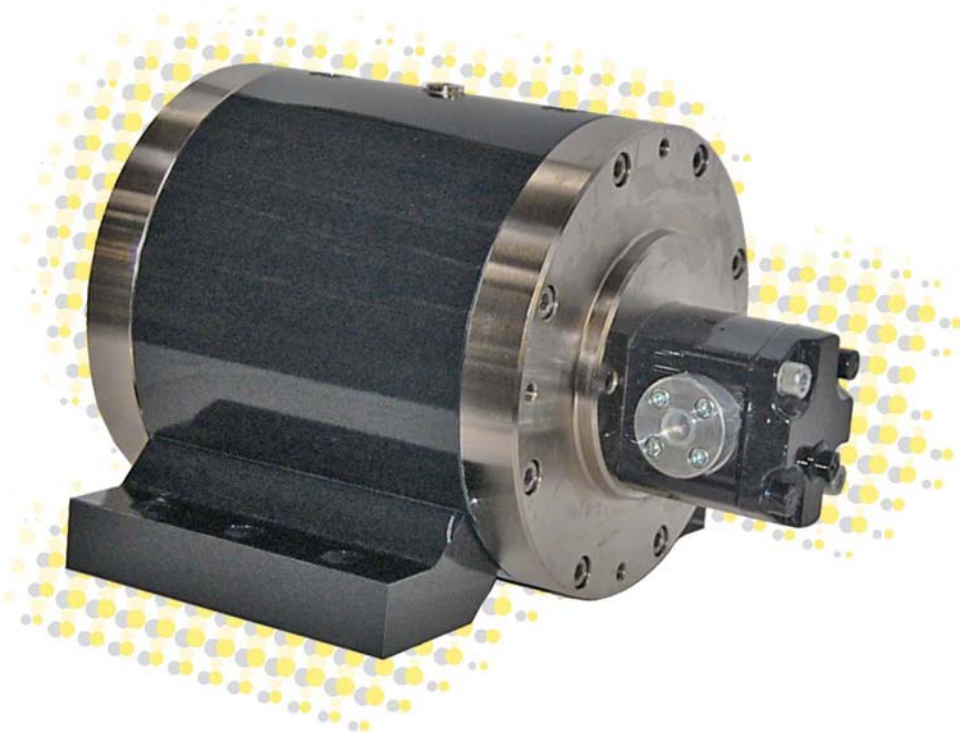

32

Netter Hydraulic External Vibrators Series NHG L



- Rotary vibration
- Nominal frequency from 3.000 min⁻¹ to 7.000 min⁻¹
- Centrifugal force from 4.070 N to 61.206 N
- Frequency continuously variable via volume flow rate



NHG 500 L



NHG 3000 L



NHG 6000 L



NetterVibration



Netter Hydraulic External Vibrators Series NHG L

Type	Unbalance [cmkg]	Frequency [U/min]	Normal Operation 100%		Short operation ≤ 60%		Weight [kg]	
			Centrifugal Force [N]	Oil requirement [l/min]	Centrifugal Force [N]	Oil Requirement [l/min]		
NHG 500 L	2,06	6.000	4.070	12	7.000	5.550	14	6,4
NHG 600 R L	0 bis 3	6.000	5.922	12	7.000	5.723*	14	8,2
NHG 900 L	6,64	4.000	5.870	8	5.000	9.100	10	7,7
NHG 3000 L	29,18	3.500	19.600	20	4.000	25.600	22	29,0
NHG 6000 L	124,00	3.000	61.206	48	—	—	—	96,0

*) The unbalance must be reset to 2,19 cmkg.

Type	A [mm]	B [mm]	C [mm]	D [mm]	E [mm]	F [mm]	Ø G [mm]	H [mm]	I [mm]	K [mm]	Ø L [mm]	M [mm]	Ø P [mm]	Ø R [mm]
NHG 500 L NHG 600 R L NHG 900 L	194	120	120	160	24	36	17	212	80	37	G1/4	47	G1/4	G3/8
NHG 3000 L	260	195	140	200	30	80	17	310	70	50	M12x1,5	96	G3/8	G3/8
NHG 6000 L	338	259	200	300	38	98	22	389	2 x 60	59	M12x1,5	113	G3/8	G3/8

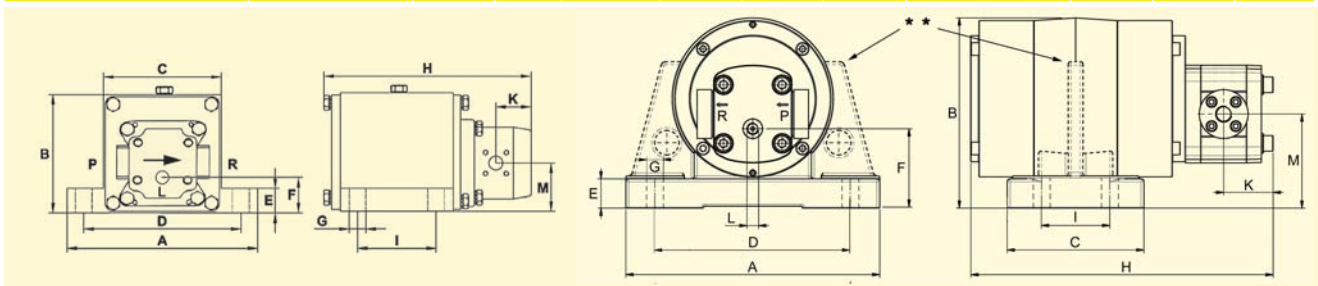

NHG 500 L, NHG 600 R L and NHG 900 L

NHG 3000 L and NHG 6000 L ***) Side strut at NHG 3000 L



NHG 3000 L



Emptying silo vehicles



NHG 900 L

Applications

Series NHG L hydraulic external vibrators are particularly suitable for emptying containers and bulk material hoppers containing adherent bulk materials, for preventing bridging and tubing and for compacting various materials.

A special characteristic is its use for unloading transport vehicles, e.g. trucks, silo buses and ships.

The vibrators are driven via the hydraulic system belonging to the carrier vehicle, and are therefore independent of any external energy supply.

Design and functioning principle

The rotary vibration is created by an unbalance. High rotational speeds result in large centrifugal forces.

The rotational speed, and hence the centrifugal force, can be regulated continuously via the volume flow rate.

NHG 500 L, NHG 900 L and NHG 3000 L and NHG 6000 L have fixed working moments.

The unbalance of the NHG600 RL can be adjusted in steps, from the outside.

Series NHG L hydraulic external vibrators are also available without an overflow oil line connection. The pressure in the return line must not exceed 2 bar.

Permissible operating conditions:

Drive Medium:

Clean, filtered hydraulic oil DIN 51524/25 or engine oil DIN 51511

Operating pressure:

Pressure side 200 bar max.
Overflow oil line back pressure 2 bar max.

Ambient temperature:

-20°C to 80°C NHG 500 L to NHG 900 L
-20°C to 60°C NHG 3000 L
-20°C to 40°C NHG 6000 L

NetterVibration offers the accessories required for the mounting, installation, control and monitoring of vibrators and impactors.

Netter provides solutions.

Consult our experienced application technicians.

Netter GmbH

Germany
Fritz-Ullmann-Str. 9
55252 Mainz-Kastel
Tel. +49 6134 2901-0

Poland
Al. W. Korfantego 195/17
40-153 Katowice
Tel. +48 32 2050947

Switzerland
Erlenweg 4
4310 Rheinfelden
Tel. +41 61 8316200

Spain
Errota Kalea 8
20150 Villabona-Guipúzcoa
Tel. +34 943 694 994

www.NetterVibration.com
info@NetterVibration.com

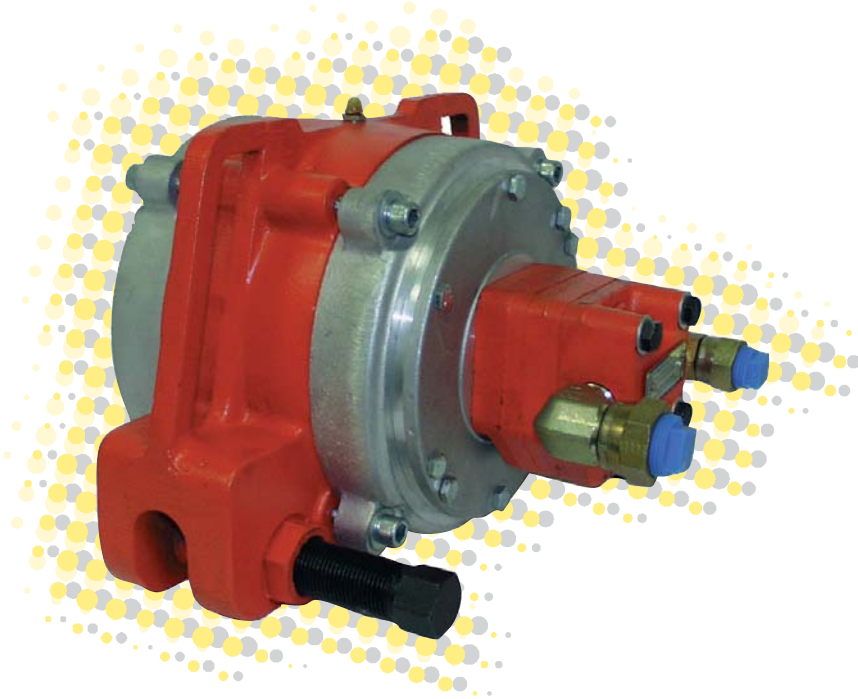

30

Netter Hydraulic External Vibrators Series CC, CV, CCV and DV



- Driven by flanged hydraulic motor
- Nominal frequency from 1.750 min^{-1} to 5.400 min^{-1}
- Centrifugal force from 7.320 N to 49.210 N
- Frequency continuously adjustable by hydraulic pressure
- High working moment, high amplitude
- Low unit weight combined with high capacity
- Mounting by attachment screw (CCV), bracket (CC) or flange (CV/DV)



CV 2.8



CC 2.8



CCV 6



DV 6



Netter Hydraulic External Vibrators Series CC, CV, CCV and DV

Type	Unbalance adjustment **	Working moment [cmkg]	Starting pressure [bar]	Frequency* [U/min]	Volume flow [l/min]	Centrifugal force [N]	Frequency* [U/min]	Volume flow [l/min]	Centrifugal force [N]	Weight [kg]
CC2.8-5HB	1	18,3	13	2.700	15,5	7.320	4.400	26,5	19.430	17,0
	2	18,0	12	2.800	15,9	7.740	4.500	25,7	19.990	
CV2.8-5HB	3	16,9	10	2.800	17,0	7.270	4.600	26,9	19.610	16,5
CCV 4-5HB	4	15,3	9	3.300	18,9	9.140	4.800	27,3	19.330	20,0
DV 4-5HB	5	12,8	9	3.800	21,6	10.140	5.000	28,8	17.550	19,0
	6	9,8	7	4.000	22,7	8.600	5.400	30,3	15.670	
CCV6-12-8HA	0 - 100 %	28	8	2.750	34,0	11.610	3.500	45,8	18.810	39,0
DV6-12-8HA										44,7
CCV6-25-8HA	0 - 100 %	59	9	2.500	30,7	20.220	3.900	43,5	49.210	40,4
DV6-25-8HA										46,1
CCV6-50-8HA	0 - 100 %	119	11	1.750	23,5	19.980	2.600	34,1	44.110	44,2
DV6-50-8HA										49,9

CC = mounting with bracket NVH
CCV = mounting with attachment screw

DV/CV = mounting with flange screw
5 HB/8 HA = hydraulic motor

* Notice: Hydraulic external vibrators for higher frequency see leaflet series NHG.

**The working moment of series CC, CV, CCV and DV 2.8/4 is adjustable in 6 steps.

Type	A [mm]	B [mm]	C [mm]	D [mm]	E [mm]	F [mm]	G [mm]	H [mm]	Outlet J	Inlet K
CV 2.8	250,8	174,6	249,2	203,2	76,2	87,3	23,8	22,0	3/4"	1/2"
CC 2.8	228,6	181,0	241,3	-	76,2	87,3	-	-	3/4"	1/2"
CCV 4	292,1	209,6	244,5	209,6	23,8	104,8	-	-	3/4"	1/2"
DV 4	304,8	206,4	244,5	4 bores: 63,5 x 266,7	101,6	101,6	22,2	16,5	3/4"	1/2"
CCV 6	368,3	287,3	320,7	285,8	25,4	142,9	-	-	3/4"	1/2"
DV 6	457,2	279,4	320,7	6 bores: 50,8 x 50,8 x 406,4	152,4	141,3	28,6	22,0	3/4"	1/2"

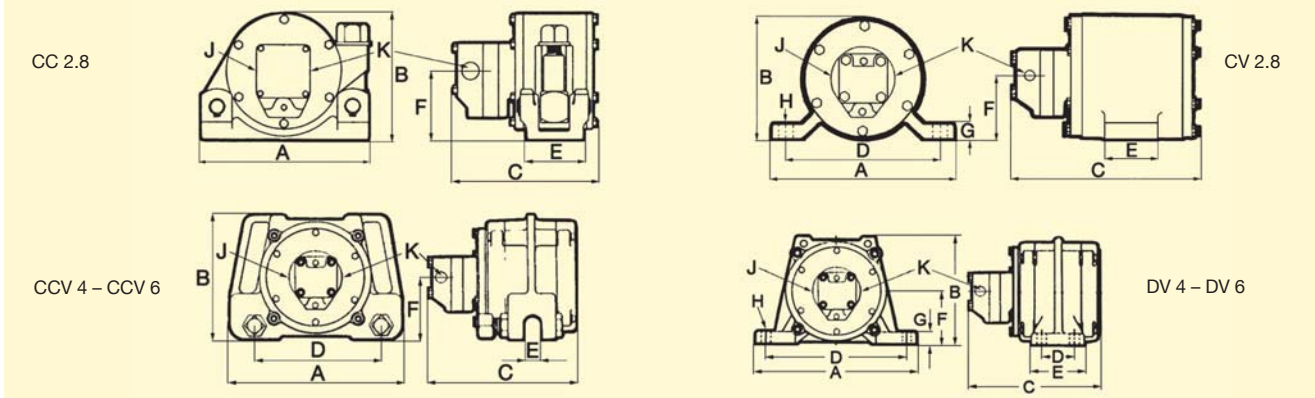

Application

Netter hydraulic external vibrators series CV, CC, CCV and DV are especially suitable to unload rail wagons and bulk hoppers as well as for the sieving and compacting of different materials.

Trucks and tractors which use hydraulic energy for dumping and lifting, are sources of hydraulic power.

A special feature of CC/CCV vibrators is the quick manual repositioning.

Design and functioning principle

The vibration (circular) is produced by unbalance pairs with double bearings.

The frequency and thus the centrifugal force are continuously adjustable by the volume flow. The hydraulic external vibrators generate high amplitudes with low frequencies.

The working moment of series CC, CV, CCV and DV 2.8/4 is adjustable in 6 steps. The working moment of series DV 6-12,

-25 and -50 is continuously adjustable. The only difference between the units is the execution of the housings. The vibrators generate very high forces in proportion to their weight.

Permissible operating conditions

Drive medium:

Hydraulic oil (clean and filtered)
DIN 51524/25 or motor oil DIN 51511

Operating pressure:

Max. 80 bar inlet,
max. 2 bar outlet.

Ambient temperature:

- 20°C to 60°C

NetterVibration offers the accessories required for the mounting, installation, control and monitoring of vibrators and impactors.

Netter provides solutions.

Consult our experienced application technicians.

Netter GmbH

Germany

Fritz-Ullmann-Str. 9
55252 Mainz-Kastel
Tel. +49 6134 2901-0

Poland

Al. W. Korfantego 195/17
40-153 Katowice
Tel. +48 32 2050947

Switzerland

Erlenweg 4
4310 Rheinfelden
Tel. +41 61 8316200

Spain

Errota Kalea 8
20150 Villabona-Guipúzcoa
Tel. +34 943 694 994

www.NetterVibration.com
info@NetterVibration.com



29

Netter Mass Concrete Compacting Unit Series NVI



- Compaction of mass concrete of biggest granulometry
- Variable mounting
- Driven by the hydraulic system of the carrier, independently of external power supplies





Netter Mass Concrete Compacting Unit Series NVI

Mass concrete compacting equipment	Number of vibrators NHR 150	Theoretical concrete compacting capacity* [m³/h]	Required raising force of the excavator** [kN]	Required oil volume at 180 bar [l/min]	Total weight [kg]
NVI 2	2	70 – 100	7,5	32	660
NVI 3	3	105 – 150	8,6	48	730
NVI 4	4	140 – 200	10,3	64	850
NVI 6	6	210 – 300	12,8	96	1.000
NVI 8	8	240 – 400	16,7	128	1.300

* depends on concrete characteristics and on-site conditions.

Only the time of compacting is considered (without moving or reposition of the excavator).

** Beside this, the hydraulic system of the excavator must have enough reserve capacity for the necessary movements of the boom.

Vibrator	Head diameter [mm]	Total length [mm]	Head length [mm]	Working speed [min⁻¹]	Centrifugal force [N]
NHR 150	150	1.190	550	7.500	21.468

Schematic view of NVI-Types:*

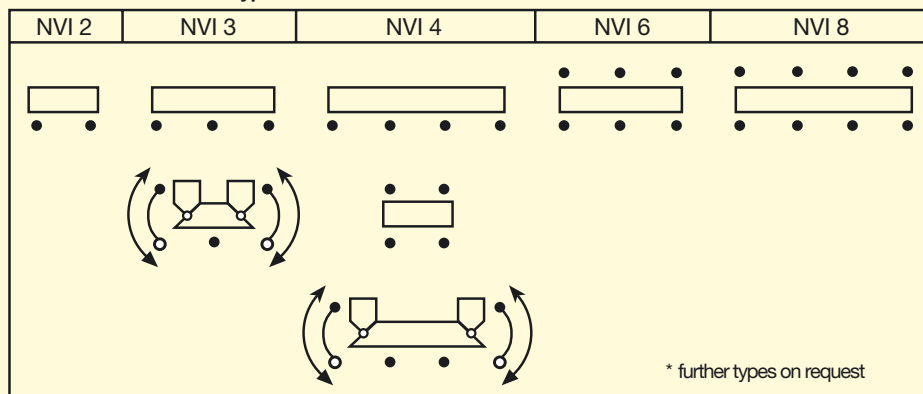

An extract from the Netter reference list

Construction project	Number of NHR 150	Type NVI	Carrier
Harbour of Valencia (Spain)	1 x 4	NVI – 4	CAT 224 B
Donaukraftwerk Freudenuau (Austria)	1 x 2	NVI – 2	Hitachi Airman AX 45
Yichang Three Gorges (China)	1 x 6	NVI – 6	Sumitomo SH 100
Baglihar Dam (India)	6 x 3	NVI – 3	CAT 307
Leibis Lichte Damm (Germany)	2 x 3	NVI – 3	CAT 307
Marsyangdi Hydro-Electric Project (Nepal)	1 x 3	NVI – 3	CAT 307
Tsankov Kamak Dam (Bulgaria)	1 x 4	NVI – 4	Liebherr R 308

Applications

Netter hydraulic internal vibrators series NHR 150 are particularly suitable for the compaction of concrete of biggest granularity (up to 250 mm grain diameter).

Design and function

The vibrators are suspended on a mounting beam by cardans. Various designs of mounting beams are available, also variable ones (see diagram). Hydraulic excavators, loaders and dozers come into question for use as carrier vehicles. For example, the existing bucket of a hydraulic excavator can be removed and replaced by a Netter mass concrete compaction unit series NVI.

The complete controls for the NHR 150 vibrators are integrated in the mounting beam.

The existing supplementary hammer-/scissors operation equipment can generally be used for hydraulic supply and operation. Thus no further modifications to the carrier vehicle are required.

NetterVibration offers the accessories required for mounting, installation, control and monitoring of vibrators.

Netter provides solutions. Consult our experienced application technicians.

Netter GmbH

Germany
Fritz-Ullmann-Str. 9
55252 Mainz-Kastel
Tel. +49 6134 2901-0

Poland
Al. W. Korfantego 195/17
40-153 Katowice
Tel. +48 32 2050947

Switzerland
Erlenweg 4
4310 Rheinfelden
Tel. +41 61 8316200

Spain
Errota Kalea 8
20150 Villabona-Guipúzcoa
Tel. +34 943 694 994

www.**NetterVibration.com**
info@**NetterVibration.com**



15

Netter Vacuum Fixing Devices for Vibrators Series VAC



- Quick mounting without bolting or welding
- Strong connection due to high vacuum
- Can also be used on curved or uneven surfaces
- Optional air economizer
- ATEX conform and stainless steel versions available
- Customized versions possible



VAC 10 with NCT 4



VAC 15 with PKL 740 ST



VAC 30 with NTS 50/04



Netter Vacuum Fixing Devices for Pneumatic Vibrators Series VAC

Type + Hose set	Air consumption without vibration [l/min]		Weight [kg]	Minimum-Ø for round containers [mm]	Suitable vibrators						
	4 bar	6 bar			NCB	NCR	NCT	NTK	NTS	NTP	PKL
VAC 8 +HG 10 N	40	60	0,95	110	1, 2		1, 2	8 AL, 15 X	120 HF, 120NF*	25**	
VAC 8 +HG 10 S	20	22	1,20					16, 18 AL	180HF, 180NF*		
VAC 10+HG 10 N	40	60	1,05	110	1, 2, 3	3	3, 4	15X, 18AL	180HF, 180NF*	25**	190**
VAC 10+HG 10 S	20	22	1,30						250HF, 250NF*		
VAC 11 +HG 10 N	40	60	1,25	110	3, 5	10	5, 10	18 AL	180HF, 180NF		190**
VAC 11 +HG 10 S	20	22	1,50						250HF, 250 NF		450**
VAC 12+HG 15 N	60	122	2,85	350	10, 20	22	15, 29	25 AL	350HF, 350 NF	25**, 32**, 48**	450**
VAC 12+HG 15 S	29	36	3,20						100/01, 75/01**, 50/01**		740**
VAC 13+HG 15 N	110	170	4,20	850	10, 20	22	15, 29		75/01, 50/01	32**	740, 2100
VAC 13+HG 15 S	41	52	4,55								5000
VAC 15+HG 15 N	110	170	3,40	650	10, 20	22	15, 29	18AL, 25	250HF, 250NF, 350HF, 350NF	32, 48*	740
VAC 15+HG 15 S	41	52	3,75			50, 70	57*		55, 108*	75/01, 50/01, 70/02*	
VAC 20+HG 15 N	110	170	7,25	850			57		70/02, 54/02, 50/04*	32, 48	2100
VAC 20+HG 15 S	41	52	7,60								5000
VAC 30+HG 30 N	110	170	11,50	1.500			120	126, 250	50/04, 50/08*	NVG 49, 55, 61 NVG 82, 84*	5000
VAC 30+HG 30 S	49	60	12,00								
VAC 40+HG 40 N	220	340	20,00	1.500					50/08*, 50/10*		

The technical data are comparative values and can vary depending on the application. Additional data available upon request. Subject to technical changes. *Depending on application, please consult **NetterVibration**. **Adapter plate necessary, please include in order!

Type	Model	A [mm]	B [mm]	C [mm]	D [mm]	E [mm]	F [mm]	Type	Model	A [mm]	B [mm]	C [mm]	D [mm]	E [mm]	F [mm]
VAC 8	I	19	8	150	127	30	55	VAC 13	III	70	30	186	241	195	197
VAC 10	I	22	8	200	175	26,5	55	VAC 15	II	56	25	345	290	100	150
VAC 11	I	20	5,5	300	276	26	55	VAC 20	II	70	30	425	370	150	200
VAC 12	I	25	10	300	268	68	100	VAC 30	IV	70	30	396	339	426	370
								VAC 40	V	70	25	426	375,6	425	370

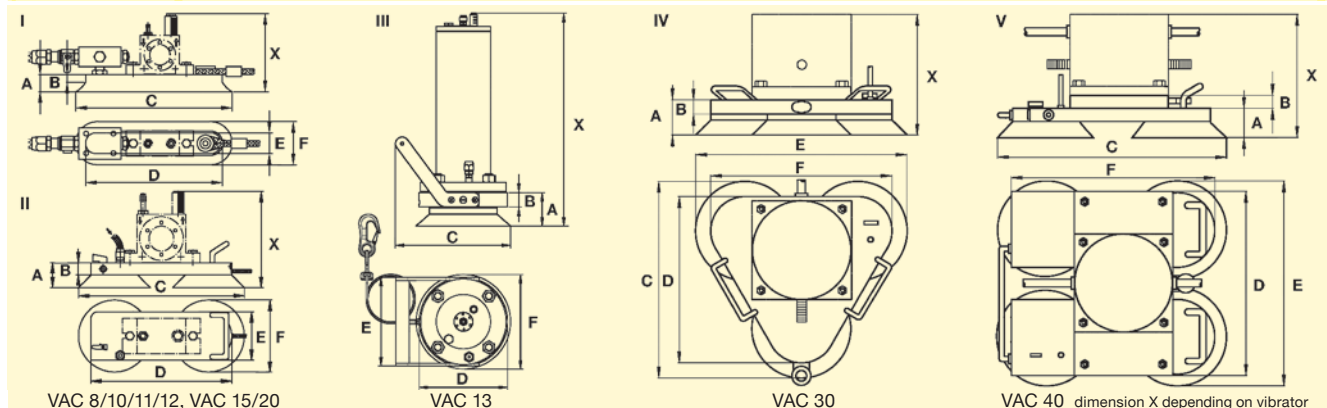

Application

The vacuum fixing devices VAC are designed to allow quick attachment of vibrators to smooth or, under circumstances, uneven and curved surfaces. A special feature of the vacuum fixing is the ease of attachment, which requires no welding or bolting.

Construction and working principle

The appropriate vibrator is screwed to the vacuum fixing and connected to the supply hose leading to the hand valve.

As soon as the vacuum fixing is connected to the compressed air supply, the unit is sucked tightly to the mounting surface, thus ensuring a strong connection between the vibrator and the surface.

The air economizer "S" creates a reduced vacuum, which is sufficient to clamp the vibrator when it is not running and which reduces the air consumption by over 30%.

ATEX conform vacuum fixings series VAC and units with stainless steel plate are available.

When the vibrator starts, the fixing device automatically produces the full vacuum.

Permissible operating conditions

Drive medium:

Compressed air or nitrogen (Filter ≤ 5 µm)

Operating pressure:

2 bar to 6 bar

Ambient temperature:

-10°C to 60°C

NetterVibration offers the accessories required for mounting, installation, control and monitoring of vibrators and impactors.

Netter provides solutions.

Consults our experienced application technicians.

Netter GmbH

Germany

Fritz-Ullmann-Str. 9
55252 Mainz-Kastel
Tel. +49 6134 2901-0

Poland

Al. W. Korfantego 195/17
40-153 Katowice
Tel. +48 32 2050947

Switzerland

Erlenweg 4
4310 Rheinfelden
Tel. +41 61 8316200

Spain

Errota Kalea 8
20150 Villabona-Guipúzcoa
Tel. +34 943 694 994

www.NetterVibration.com
info@NetterVibration.com



23



Netter Pneumatic Turbine Vibrators Series NCT

- Rotary vibration
- Resistant to aggressive environmental conditions
- Unrestricted, lubrication-free operation
- Nominal frequency from 4.900 min^{-1} to 45.460 min^{-1}
- Centrifugal force from 288 N to 8.659 N
- Frequency continuously adjustable by means of air pressure
- Reduced noise level
- Maintenance-free due to continuously lubricated rolling bearing
- Available in ATEX conform or in stainless steel versions





Netter Pneumatic Turbine Vibrators Series NCT

Type	Working moment [cmkg]	Nominal frequency [min ⁻¹]			Centrifugal force [N]			Air consumption [l/min]		Noise level [dB(A)]	
		2 bar	4 bar	6 bar	2 bar	4 bar	6 bar	2 bar	6 bar	2 bar	6 bar
NCT 1	0,006	29.100	38.820	45.460	288	513	703	19	45	68	83
NCT 2	0,012	21.360	29.520	34.000	311	594	787	20	48	66	81
NCT 3	0,016	26.940	34.900	39.700	637	1.069	1.383	28	75	63	77
NCT 4	0,023	21.740	26.920	30.380	597	915	1.165	31	73	62	76
NCT 4i	0,046	14.020	18.560	21.000	496	869	1.112	31	75	61	73
NCT 5	0,049	22.740	27.840	30.940	1.389	2.082	2.572	93	284	74	90
NCT 10	0,096	16.940	20.680	22.980	1.511	2.251	2.780	92	287	66	78
NCT 10i	0,192	12.200	14.680	16.420	1.567	2.269	2.839	93	286	63	77
NCT 15	0,160	15.740	20.060	22.700	2.174	3.530	4.521	215	461	72	84
NCT 29	0,282	11.920	14.760	16.740	2.197	3.369	4.334	216	461	66	78
NCT 29i	0,564	7.360	10.240	11.780	1.676	3.243	4.291	213	463	63	77
NCT 55	0,545	11.000	13.980	15.760	3.618	5.845	7.426	386	918	77	85
NCT 108	1,081	8.280	10.420	11.720	4.067	6.441	8.152	379	911	73	84
NCT 108i	2,161	4.900	6.860	8.000	2.860	5.590	7.591	392	927	66	77
NCT 126	1,262	6.060	8.280	9.400	2.591	4.760	6.124	653	1.707	71	83
NCT 250	2,502	5.500	7.020	7.800	4.152	6.761	8.348	655	1.710	71	82
NCT 250i	5,000	-	5.100	5.620	-	7.131	8.659	1.222*	1.732	70	74

The technical data are relative values and can vary depending on the application. Additional data available upon request. *at 4 bar

Type	A [mm]	B [mm]	C [mm]	D [mm]	E [mm]	F	G* [mm]	H* [mm]	K [mm]	Weight [kg]
NCT 1	40	27	70	56	6,5	G 1/8	30	5,5	10	0,165
NCT 2	40	27	70	56	6,5	G 1/8	30	5,5	10	0,162
NCT 3	50	32	86	68	7	G 1/8	40	7	12	0,230
NCT 4	50	32	86	68	7	G 1/8	40	7	12	0,240
NCT 4i	50	32	86	68	7	G 1/8	40	7	12	0,250
NCT 5	65	43	113	90	9	G 1/4	50	9	16	0,550
NCT 10	65	43	113	90	9	G 1/4	50	9	16	0,570
NCT 10i	65	43	113	90	9	G 1/4	50	9	16	0,610
NCT 15	80	56	128	104	9	G 1/4	60	10	16	1,045
NCT 29	80	56	128	104	9	G 1/4	60	10	16	1,090
NCT 29i	80	56	128	104	9	G 1/4	60	10	16	1,180
NCT 55	100	73	160	130	13	G 3/8	80	12	20	2,125
NCT 108	100	73	160	130	13	G 3/8	80	12	20	2,250
NCT 108i	100	73	160	130	13	G 3/8	80	12	20	2,500
NCT 126	120	86	194	152	17	G 3/8	100	13	25	3,585
NCT 250	120	86	194	152	17	G 3/8	100	13	25	3,820
NCT 250i	120	86	194	152	17	G 3/8	100	13	25	4,290

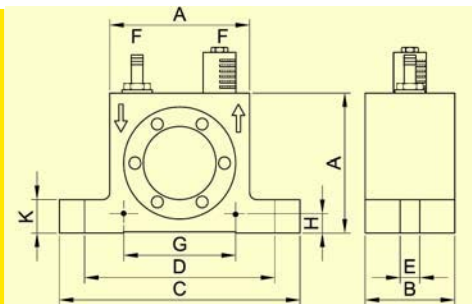

* dimensions for mounting horizontal, bore ØE

Sifting of fine grained products

Applications

Series NCT pneumatic turbine vibrators are particularly suitable for moving bulk materials. They can be used for emptying bunkers, driving chutes, sieves and vibrating tables and for the mechanical stimulation of processes.

Special features of the NCT vibrators are high frequency at low noise level and low air consumption.

Design and functioning principle

The rotary vibration is produced by an eccentrically mounted turbine with integrated unbalance masses. The frequency and therefore the centrifugal force can be continuously regulated via the operating pressure.

A directional control valve is necessary for operation (not supplied).

ATEX conform series NCT turbine vibrators and units with stainless steel housings are available.

Permissible operating conditions

Drive medium:

Compressed air or nitrogen (filter ≤ 5µm), unrestricted, lubrication-free operation

Operating pressure:

2 bar to 6 bar

Ambient temperature:

-20°C to 120°C

NetterVibration offers the accessories required for the mounting, installation, control and monitoring of vibrators and impactors.

Netter provides solutions.

Consult our experienced application technicians.

Netter GmbH

Germany

Fritz-Ullmann-Str. 9
55252 Mainz-Kastel
Tel. +49 6134 2901-0

Poland

Al. W. Korfantego 195/17
40-153 Katowice
Tel. +48 32 2050947

Switzerland

Erlenweg 4
4310 Rheinfelden
Tel. +41 61 8316200

Spain

Errota Kalea 8
20150 Villabona-Guipúzcoa
Tel. +34 943 694 994

www.NetterVibration.com
info@NetterVibration.com



20

Netter Pneumatic Roller Vibrators



Series NCR

- Rotary vibration
- Suitable for aggressive environmental conditions
- High propulsive power
- Nominal frequency from 10.140 min⁻¹ to 34.304 min⁻¹
- Centrifugal force from 878 N to 9.100 N
- Frequency continuously adjustable via air pressure
- Suitable for temperatures up to 200°C





Netter Pneumatic Roller Vibrators Series NCR

Type	Working moment [cmkg]	Nominal frequency [min ⁻¹]			Centrifugal force [N]			Air consumption [l/min]		Noise level [dB(A)]	
		2 bar	4 bar	6 bar	2 bar	4 bar	6 bar	2 bar	6 bar	2 bar	6 bar
NCR 3	0,031	22.699	30.480	34.304	878	1.579	2.000	55	146	74	85
NCR 10	0,102	20.180	24.520	27.760	2.278	3.363	4.311	121	301	74	86
NCR 22	0,224	16.400	20.040	21.780	3.313	4.933	5.828	162	424	77	87
NCR 57	0,572	12.480	14.370	15.465	4.902	6.489	7.520	246	574	74	91
NCR 120	1,200	10.140	11.680	11.760	6.765	8.976	9.100	315	768	86	97

The technical data are comparative values and can vary depending on application. Additional data available upon request.

Type	A [mm]	B [mm]	C [mm]	D [mm]	E [mm]	F	G* [mm]	H* [mm]	K [mm]	Weight [kg]
NCR 3	51	28,5	86	68	7	G 1/8	40	7	12	0,260
NCR 10	67	36	113	90	9	G 1/4	50	9	16	0,579
NCR 22	80	42,5	128	104	9	G 1/4	60	10	16	0,986
NCR 57	100	51	160	130	13	G 3/8	80	12	20	1,875
NCR 120	120	75	194	152	17	G 3/8	100	13	24	4,362

*dimensions for mounting horizontal, bore ØE

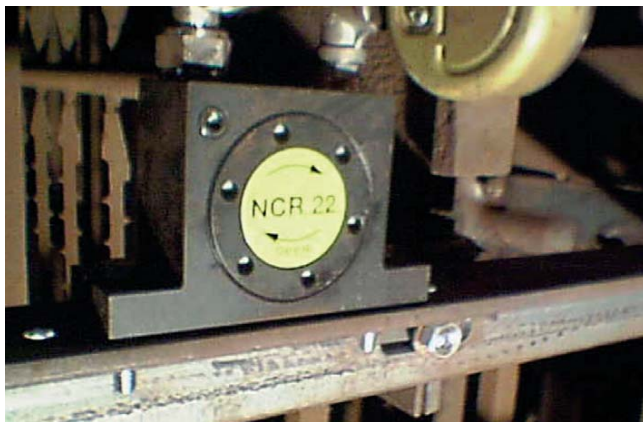
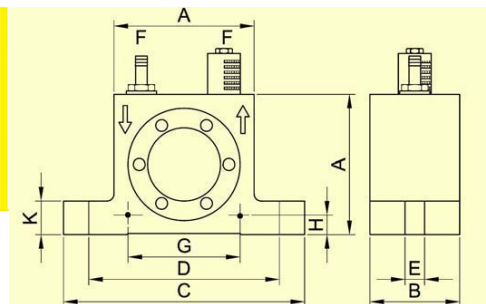

Dusting off filter wires



Emptying silo trailers

Applications

Pneumatic roller vibrators series NCR are particularly suitable for the elimination or reduction of friction.

They can be used for emptying bunkers and preventing adhesion to pipes and plates. Special features of the NCR vibrators are very high frequencies, high centrifugal forces and insusceptible resonance behaviour.

Construction and working principle

The rotary vibration is created by the high centrifugal force of a circulating steel roller, which runs on a steel ring at very high frequency.

The frequency, and hence the centrifugal force, can be continuously regulated via the operating pressure.

Series NCR roller vibrators can be operated using lubrication-free compressed air.

A multi-directional valve is required for operation (not supplied).

Permissible Operating Conditions

Drive medium:

Compressed air or nitrogen (filter ≤ 5µm) preferably with oil mist

Operating pressure:

2 bar to 6 bar

Ambient temperature:

-20°C to 120°C

HT version for temperatures up to 200°C

NetterVibration offers the accessories required for the mounting, installation, control and monitoring of vibrators and impactors.

Netter provides solutions.

Consult our experienced application technicians.

Netter GmbH

Germany

Fritz-Ullmann-Str. 9
55252 Mainz-Kastel
Tel. +49 6134 2901-0

Poland

Al. W. Korfanteo 195/17
40-153 Katowice
Tel. +48 32 2050947

Switzerland

Erlenweg 4
4310 Rheinfelden
Tel. +41 61 8316200

Spain

Errota Kalea 8
20150 Villabona-Guipúzcoa
Tel. +34 943 694 994

www.NetterVibration.com
info@NetterVibration.com

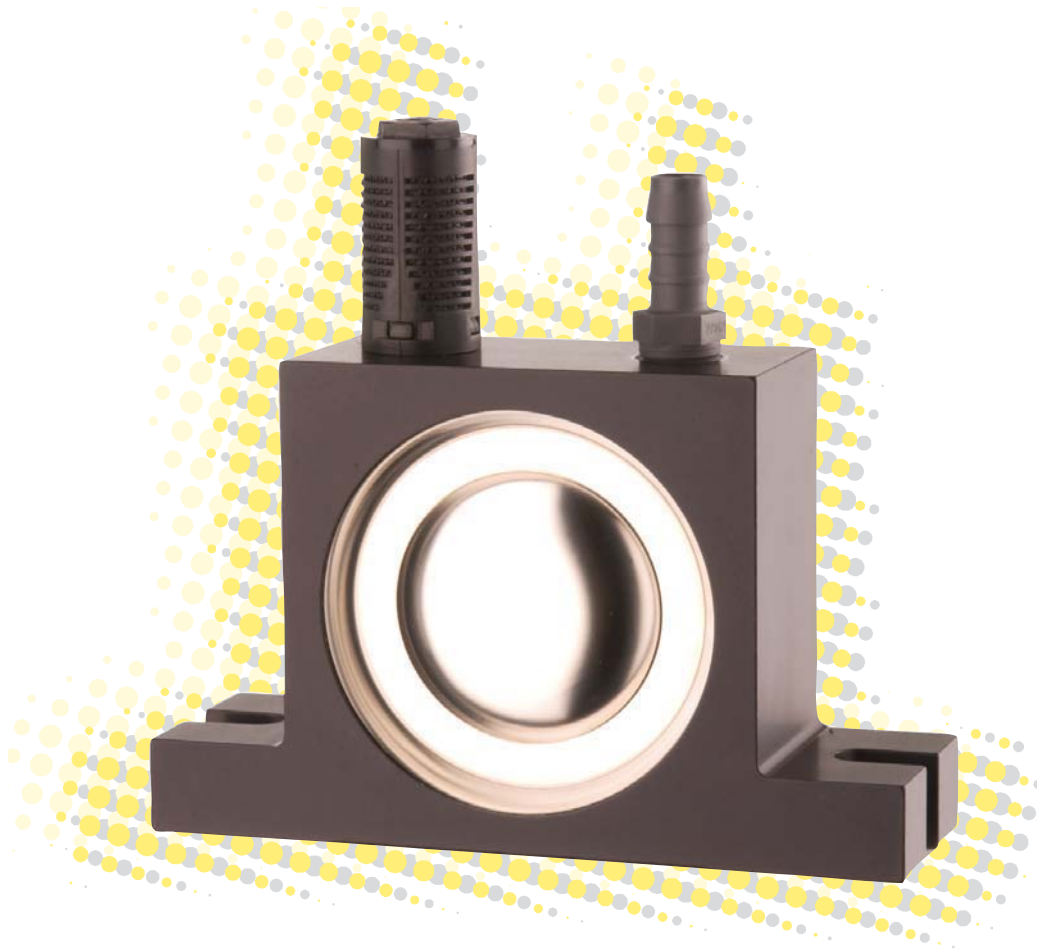

18

Netter Pneumatic Ball Vibrators Series NCB



- Rotary vibration
- Nominal frequency from 7.220 min⁻¹ to 42.340 min⁻¹
- Centrifugal force from 222 N to 4.866 N
- Frequency continuously adjustable via air pressure
- Suitable for temperatures up to 200°C



NCB 1



NCB 10

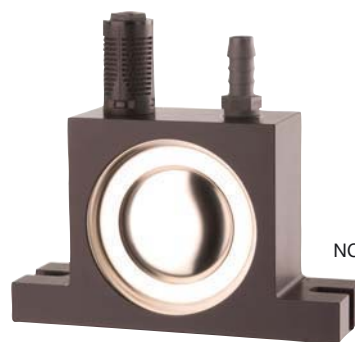

NCB 50



Netter Pneumatic Ball Vibrators Series NCB

Type	Working moment [cmkg]	Nominal frequency [min ⁻¹]			Centrifugal force [N]			Air consumption [l/min] 2 bar - 6 bar	Noise level* [dB(A)] 2 bar - 6 bar
		2 bar	4 bar	6 bar	2 bar	4 bar	6 bar		
NCB 1	0,005	28.460	37.060	42.340	222	377	491	38 - 112	71 - 79
NCB 2	0,009	22.880	31.160	37.540	258	479	696	38 - 115	74 - 79
NCB 3	0,029	17.100	21.600	24.360	465	742	947	81 - 219	74 - 82
NCB 5	0,046	15.220	19.180	22.480	587	933	1.277	77 - 217	78 - 85
NCB 10	0,131	11.320	14.380	16.380	921	1.486	1.928	226 - 463	82 - 89
NCB 20	0,211	10.560	13.780	15.420	1.298	2.198	2.753	222 - 468	78 - 86
NCB 50	0,522	7.220	9.940	11.220	1.492	2.828	3.603	312 - 733	80 - 86
NCB 70	0,808	7.220	8.820	10.480	2.310	3.446	4.866	310 - 728	75 - 84

*Specific silencer to reduce the noise level available.

Type	A [mm]	B [mm]	C [mm]	D [mm]	E [mm]	F	G* [mm]	H* [mm]	K [mm]	Weight [kg]
NCB 1	50	18	86	68	7	G 1/8	40	7	12	0,12
NCB 2	50	18	86	68	7	G 1/8	40	7	12	0,13
NCB 3	65	26	113	90	9	G 1/4	50	9	16	0,29
NCB 5	65	26	113	90	9	G 1/4	50	9	16	0,32
NCB 10	80	37	128	104	9	G 1/4	60	10	16	0,60
NCB 20	80	37	128	104	9	G 1/4	60	10	16	0,70
NCB 50	100	50	160	130	11	G 3/8	80	12	20	1,30
NCB 70	100	50	160	130	11	G 3/8	80	12	20	1,50

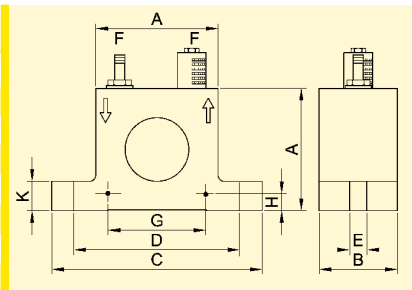

*Dimensions for horizontal mounting, bore ØE



Sorting and aligning



Emptying without bridging

Applications

Series NCB pneumatic ball vibrators can be used wherever bulk materials need to be moved.

They serve in the emptying of bunkers, for preventing bridging, rat-holing and adhesion. When used to drive chutes, sieves and vibrating tables, they ensure that the material flow is maintained.

The special feature is the simple construction.

Construction and Working Principle

The rotary vibration is created by the high centrifugal force produced by a circulating steel ball, which runs on hardened, polished steel races.

The frequency, and hence the centrifugal force, can be continuously regulated via the operating pressure.

Series NCB ball vibrators can be operated using lubrication-free compressed air.

A multi-directional valve is required for operation (not included in the scope of supply).

Permissible Operating Conditions

Drive medium:

Compressed air or nitrogen (filter ≤ 5 µm), preferably with oil mist

Operating pressure:

2 bar to 6 bar

Ambient temperature:

-20°C to +120°C
HT version up to +200°C

NetterVibration offers the accessories required for the mounting, installation, control and monitoring of vibrators and impactors.

Netter provides solutions.

Consult our experienced application technicians.

Netter GmbH

Germany

Fritz-Ullmann-Str. 9
55252 Mainz-Kastel
Tel. +49 6134 2901-0

Poland

Al. W. Korfantego 195/17
40-153 Katowice
Tel. +48 32 2050947

Switzerland

Erlenweg 4
4310 Rheinfelden
Tel. +41 61 8316200

Spain

Errota Kalea 8
20150 Villabona-Guipúzcoa
Tel. +34 943 694 994

www.NetterVibration.com
info@NetterVibration.com



25

Netter Pneumatic Linear Vibrators Series NTS

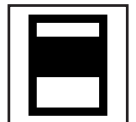

- Linear vibration
- Resistant against aggressive environmental conditions
- Nominal frequency from 827 min⁻¹ to 9.040 min⁻¹
- Centrifugal force 32 N to 21.808 N
- Frequency and amplitude can be adjusted separately
- Synchronous operation possible (NTS 350 and higher)
- Available in ATEX version or in stainless steel



NTS 120 NF



NTS 54/02



NTS 50/10



NetterVibration



Netter Pneumatic Linear Vibrators Series NTS

Type	Housing material	Working moment [cmkg]			Nominal frequency [min ⁻¹]			Centrifugal force [N]			Air consumption [l/min]		Noise level [dB(A)]	
		2 bar	4 bar	6 bar	2 bar	4 bar	6 bar	2 bar	4 bar	6 bar				
NTS 120 HF	AL	0,018	0,018	0,018	6.280	7.920	8.960	40	63	81	10	36	68	73
NTS 120 NF	AL	0,038	0,046	0,046	3.871	4.510	5.095	32	52	66	7	19	66	72
NTS 180 HF	AL	0,035	0,045	0,046	5.520	6.880	9.040	59	116	207	15	67	68	73
NTS 180 NF	AL	0,138	0,149	0,163	3.000	4.160	4.880	68	141	212	14	57	66	72
NTS 250 HF	AL	0,152	0,190	0,190	3.654	4.756	5.773	111	235	346	21	105	68	74
NTS 250 NF	AL	0,402	0,475	0,542	2.328	3.100	3.894	119	251	451	20	99	68	72
NTS 350 HF	AL	0,208	0,308	0,349	3.866	4.754	5.579	179	399	594	37	135	66	74
NTS 350 NF	AL	0,756	0,932	0,992	2.412	3.077	3.663	241	486	733	26	110	65	70
NTS 100/01*	AL	0,33	0,43	0,41	3.920	4.640	5.840	281	513	764	33	181	68	80
NTS 75/01*	AL	1,01	1,31	1,44	2.848	3.596	4.038	451	934	1.291	99	442	67	81
NTS 50/01*	AL	2,18	2,62	2,66	1.924	2.408	2.825	442	834	1.164	88	416	76	84
NTS 70/02*	AL	2,81	2,77	3,04	2.096	2.808	3.336	676	1.186	1.847	128	564	76	87
NTS 54/02*	AL	4,54	5,51	5,07	1.730	2.064	2.544	745	1.288	1.800	152	698	80	89
NTS 50/04*	AL	7,9	9,8	9,7	1.920	2.296	2.672	1.591	2.844	3.789	271	977	77	86
NTS 21/04	AL	34,9	45,9	49,1	941	1.156	1.334	1.694	3.362	4.786	225	718	73	83
NTS 50/08*	AL	11,3	15,3	17,0	1.977	2.331	2.669	2.426	4.555	6.642	216	803	81	90
NTS 50/10	GG	14,5	17,9	18,9	1.983	2.392	2.809	3.128	5.626	8.174	454	1.647	82	92
NTS 30/10	GG	50,0	80,0	96,0	840	1.044	1.300	1.940	4.780	8.900	312	1.438	75	85
NTS 50/15	GG	25,0	32,7	35,8	1.830	2.209	2.464	4.589	8.754	11.922	726	2.108	81	91
NTS 50/20	GG	24,7	34,2	37,3	1.823	2.252	2.591	4.511	9.527	13.737	887	2.491	81	92
NTS 30/20	GG	57,3	84,8	92,6	1.227	1.528	1.759	4.727	10.852	15.693	551	2.014	78	88
NTS 24/20	GG	94,2	126,6	144,8	936	1.176	1.388	4.515	9.596	15.290	642	2.083	75	80
NTS 50/40	GG	72,5	93,0	99,5	1.335	1.617	1.920	7.090	13.333	20.114	994	3.296	80	92
NTS 20/40	GG	218,9	286,7	302,3	827	985	1.147	8.227	15.239	21.808	1.340	4.252	77	89

The technical data can vary depending on application. Please request comparative values.

* oil free operation possible

Standard vibrators
NTS 120 bis NTS 350



Standard vibrators
NTS 100/01 bis NTS 20/40



Stainless steel vibrators
NTS S



ATEX compliant vibrators
NTS E

Netter Pneumatic Linear Vibrators Series NTS



Type	A	A ₁	B	C	D	ØE	F	G	H	I	K Outlet	L Inlet	Outlet on side	Housing [kg]	Piston [kg]	Total [kg]	Housing type
	[mm]	[mm]	[mm]	[mm]	[mm]	[mm]	[mm]	[mm]	[mm]	[mm]							
NTS 120 HF	97,5	70,0	27,5	SW 21	-	M 8	11	16,5	34,5	-	G1/8	G1/8	-	0,086	0,022	0,108	I
NTS 120 NF	125,0	97,5	27,5	SW 21	-	M 8	11	16,5	48,5	-	G1/8	G1/8	-	0,119	0,042	0,161	I
NTS 180 HF	108,5	73,0	33,5	SW 27	-	M10	10	19,5	35,5	-	G1/4	G1/8	-	0,124	0,050	0,174	I
NTS 180 NF	146,5	110,5	33,5	SW 27	-	M10	10	19,5	53,8	-	G1/4	G1/8	-	0,192	0,110	0,302	I
NTS 250 HF	145,5	98,0	41,5	SW 36	-	M12	12	24,0	49,0	-	G3/8	G1/8	-	0,238	0,155	0,393	I
NTS 250 NF	190,0	141,0	41,5	SW 36	-	M12	12	24,0	70,5	-	G3/8	G1/8	-	0,335	0,290	0,625	I
NTS 350 HF	146,5	99,0	53,0	SW 46	-	M12	12	30,5	49,5	-	G3/8	G1/4	-	0,359	0,325	0,684	I
NTS 350 NF	193,0	145,0	53,0	SW 46	-	M12	12	30,5	72,5	-	G3/8	G1/4	-	0,505	0,570	1,075	I

NTS 100/01	89	-	Ø69	69	-	M12	20	65,5	48,5	31,5	G1/4	G1/4	3	0,64	0,36	1,0	II
NTS 75/01	115	-	90	80	72	9	20	81	60	38	G1/4	G1/4	2	1,1	0,8	1,9	II
NTS 50/01	155	-	90	80	72	9	20	121	80	40	G1/4	G1/4	2	1,5	1,4	2,9	II
NTS 70/02	130	-	110	100	90	9	20	91	65	39	G3/8	G3/8	2	1,9	1,2	3,1	II
NTS 54/02	157	-	110	100	90	9	20	112	79	45	G3/8	G3/8	2	2,3	1,6	3,9	II
NTS 50/04	157	-	150	139	124	13	20	113	79	44	G3/8	G3/8	2	4,0	4,3	8,3	II
NTS 21/04	330	-	150	139	124	13	20	280	165	49	G3/8	G3/8	2 + 4	8,5	12,5	21	III
NTS 50/08	173	-	200	170	165	17	30	125	92	58	G3/8	G3/8	2 + 4	9,0	7,1	16,1	III

NTS 50/10	157	-	200	190	165	18	20	112	79	45	G3/8	G1/2	2 + 4	20	9,0	29	III
NTS 30/10	340	-	200	190	165	18	20	289	170	52	G3/8	G1/2	2 + 4	41	25	66	III
NTS 50/15	185	-	230	220	190	22	30	134	95	56	G3/8	G3/4	1 - 4	32	15	47	III
NTS 50/20	190	-	250	250	210	22	30	134	95	57	G3/8	G3/4	1 - 4	42	19	61	III
NTS 30/20	278	-	250	250	210	22	30	218	139	61	G3/8	G3/4	1 - 4	54	37	91	III
NTS 24/20	360	-	250	250	210	22	30	298	180	62	G3/8	G3/4	1 - 4	68	54	122	III
NTS 50/40	266	-	320	320	260	26	40	194	133	72	G1/2	G 1	1 - 4	89	52	141	III
NTS 20/40	470	-	320	320	260	25	40	392	235	78	G1/2	G 1	1 - 4	134	125	259	III

Housing type I
NTS 120 to 350

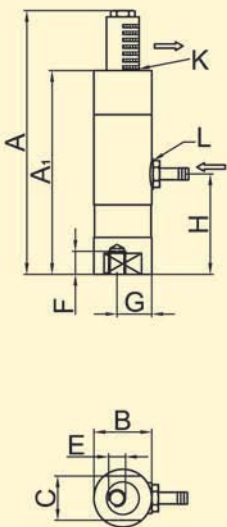

Housing type II
NTS 100/01 to NTS 50/04

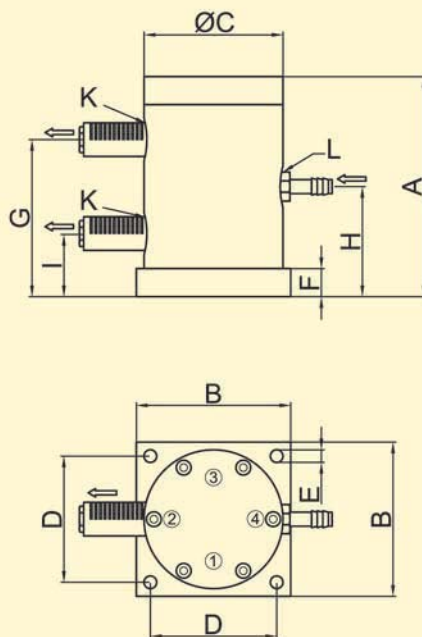

Housing type III
NTS 21/04 to NTS 20/40

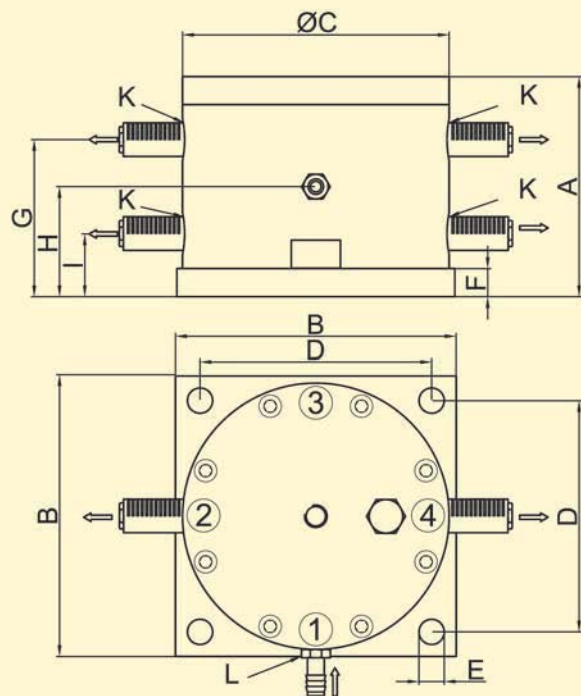



NetterVibration



Netter Pneumatic Linear Vibrators Series NTS



Filling of powder products



Maintaining material flow



Vibrating and compacting of various material in cartons



Discharging aid on the container



Conveying with Netter **PowerPack**



Compaction of form sand in foundry forms



Compaction of powder in sacks

Applications

The pneumatic linear vibrators series NTS are especially suitable for conveying, compacting and loosening bulk material, due to the completely linear vibration.

They are used to empty bins and as drives for conveyor and dosing troughs. A special feature of NTS vibrators is the possibility of the synchronous operation of several NTS when using a coupling kit. Starting from NTS 350 NF to NTS 50/08 this is available as special execution and starting from NTS 50/10 to NTS 20/40 it is standard.

Design and functioning principle

The vibration (sinus-shaped oscillation) is produced by a freely vibrating, self reversing piston. This oscillation supports, expedites or enables a variety of applications. NTS linear vibrators start and stop without delay in any installed position.

A built-in pressure spring provides a reliable start-up of vibrators with aluminium housing up to NTS 50/04 and NTS 50/08. The amplitude is set by means of the optional throttle valve.

An increase of the supply pressure causes a higher frequency. For operation a control valve is required (not included in scope of delivery). ATEX compliant linear vibrators of the NTS series and units with a stainless steel housing are available.

Permissible operating conditions

Drive medium:

Compressed air or nitrogen (Filter $\leq 5 \mu\text{m}$), preferably with oil mist

Operating pressure:

2 bar to 6 bar

Ambient temperature:

-10°C to 60°C

Aluminium housing 5°C to 60°C

NetterVibration offers the accessories required for the mounting, installation, control and monitoring of vibrators and impactors.

Netter provides solutions.

Consults our experienced application technicians.

Netter GmbH

Germany

Fritz-Ullmann-Str. 9
55252 Mainz-Kastel
Tel. +49 6134 2901-0

Poland

Al. W. Korfantego 195/17
40-153 Katowice
Tel. +48 32 2050947

Switzerland

Erlenweg 4
4310 Rheinfelden
Tel. +41 61 8316200

Spain

Errota Kalea 8
20150 Villabona-Guipúzcoa
Tel. +34 943 694 994

www.NetterVibration.com
info@NetterVibration.com